

RP75-4040 Adapter Plate for Regular Arm and Parallel Arm Applications



ASSA ABLOY

To Retrofit Norton Rixson 7500 Door Closer
for LCN 4040 Door Closer

Experience a safer
and more open world

⚠ WARNING

This product can expose you to lead which is known to the state of California to cause cancer and birth defects or other reproductive harm. For more information go to www.P65warnings.ca.gov.

Ce produit peut vous exposer au plomb qui, dans l'état de la Californie, est reconnu pour causer le cancer, des anomalies congénitales ou d'autres problèmes de reproduction. Pour plus d'informations, visitez: www.P65warnings.ca.gov.

ATTENTION:

This is a SUPPLEMENT SHEET to the Standard Installation Instructions.

Use this sheet for preparation of the door frame and the installation of the adapter plate only.

Use the installation instructions packed with the door closer for installation sequence and adjustments.

Regular Arm Mount Left Hand Shown

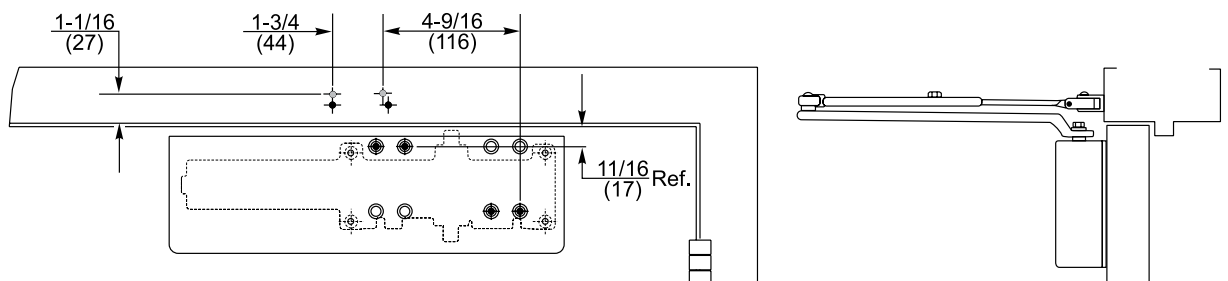

Parallel Arm Mount - For use on Standard Parallel (NHO), PR, CLP, CPS applications only. Not valid for Unitrol applications. Right Hand Shown

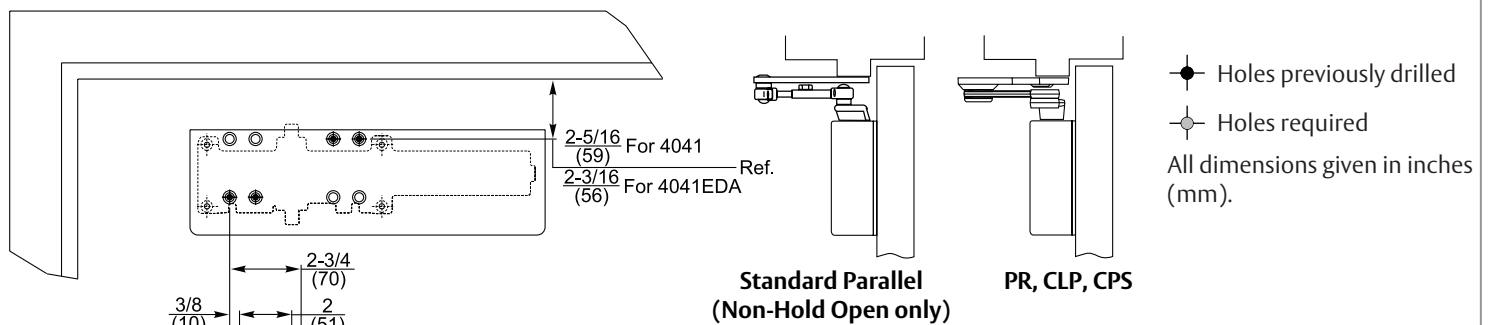

Preparation for Fasteners		
Fasteners	Door or Frame	Drill Sizes
Self-Drilling Screw	Aluminum or Metal	No drill required
	Wood*	3/16" (4.30mm)
1/4" - 20 Machine Screw	Metal	Drill: #7 (0.201" dia.) Tap: 1/4" -20

*Wood doors/frames MUST have pilot holes when using Self-Drilling screws.

1. Remove old closer body and arm assembly from door and frame.
2. Prepare new holes in frame for Regular or Parallel Arm Mount. See "Preparation for Fasteners".
3. Using existing holes, attach adapter plate to door using provided 1/4"-20 x 9/16" screws. Note: Thru bolt applications may require different fasteners.
4. Attach closer to adapter plate using 1/4"-20 x 2" screws provided (see separate Installation Instructions).
5. Attach arm assembly to frame and closer pinion (see separate installation instructions).

Technical Product Support:
Monroe, NC 28112 USA
Phone: 800.438.1951 ext: 6030
Techsupport.NortonRixson@assaabloy.com
NortonRixson.com