

Opening	Dimension "A"	
	inches	mm
To 100°	7-5/8	194
100° to 120°	6-5/8	168
120° to 150°	4-5/8	117
150° to 180°	4-1/8	105

Caution: Door swing may be limited by door, frame, wall, or hardware conditions (including closer projection).

Hollow-metal doors require channel or box-type reinforcement when thru-bolt mount is specified.

Sex-bolts required for wood or plastic faced fire-door mounting.

Minimum thickness recommended for reinforcements in hollow-metal doors and frames: .1046" (2.66) unless otherwise noted.

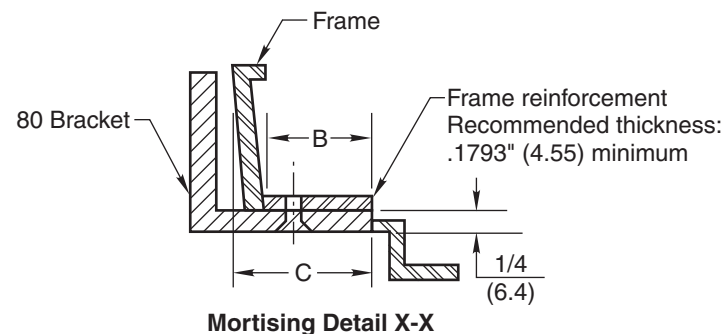

Bracket	Dimension "B"				Dimension "C"	
	Maximum		Minimum		Maximum	
	inches	mm	inches	mm	inches	mm
80	2	51	1-1/2	38	2-1/4	57

Preparation for Fasteners			
	Fasteners	Door or Frame	Drill Sizes
Standard	#14 type "A" S.M. screw Arm: 1-1/4" (32mm) Closer: 2-3/4 (70mm)	Wood	3/16" (4.30mm)
		Aluminum	7/32" (5.50mm)
	1/4-20 machine-screw	Metal	drill: #7 (.201" dia) tap: 1/4-20
Optional	Sex-nuts and bolts	Hollow-Metal	9/32" (7.00mm) through; 3/8" (9.50mm) on door or transom-face opposite to closer
		Aluminum or Wood	3/8" (9.500mm) through
	Through-bolts and grommet-nuts	All	9/32" (7.00mm) through; 3/8" (9.50mm) dia. x 3/8" (9.500mm) deep on door or transom-face opposite to closer

**7500H, 7700H, and 7700HOSP Series Door Closers
 With 80 Bracket
 With or Without 7786 Backplate
 Regular Arm Installation With Hold Open Arm**



ASSA ABLOY

TEMPLATE NUMBER	REV	DATE
7377-0107	3	12/21

Approved 2022-02-25