

A Offset	B Cutout for arm clearance
5/8	1-3/8
3/4	1-1/2
7/8	1-5/8
1-1/8	1-7/8
1-1/4	2
1-3/8	2-1/8
1-1/2	2-1/4
1-5/8	2-3/8

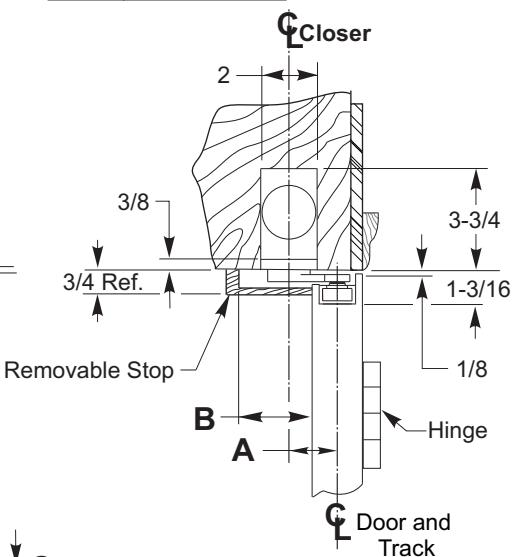

NOTES:

- Do not scale drawing.
- Left hand door shown.
- Hardware dimensions shown (not cutout).
- Dimensions are in inches.
- Minimum thickness recommended for reinforcements in hollow metal doors and frames: .1046" (2.66mm.) unless otherwise noted.
- Minimum door width 27 inches.
- Track is 24 inches long.
- Maximum width hinge is 5 inches.
- Door can swing to 180 degrees conditions permitting.

NOTE:

Removable Frame Stop must have the stop Edge nearest the Door removed to permit arm clearance. Remove a section 15" long starting 7" from the centerline of the hinge.

3/4" high frame stop at head is recommended.

Fastener	Use	⊕ Preparation
1/4-20 machine screw	Metal door	#7 (.201" dia.) Drill 1/4-20 tap
#14 wood screw	wood door	7/32" drill

**7900B Series Door Closers for 1-3/4" Thick Doors
 For Use on Doors Hung on 5" Wide Butt Hinges Maximum
 Non Hold Open Installation
 With Special offset Mounting in Wood Frame**



TEMPLATE NUMBER	REV	DATE
7379-0271	3	12/21