

**Adjustable
Hold Open**

85°-110°

Dead stop at 5° beyond hold open point.

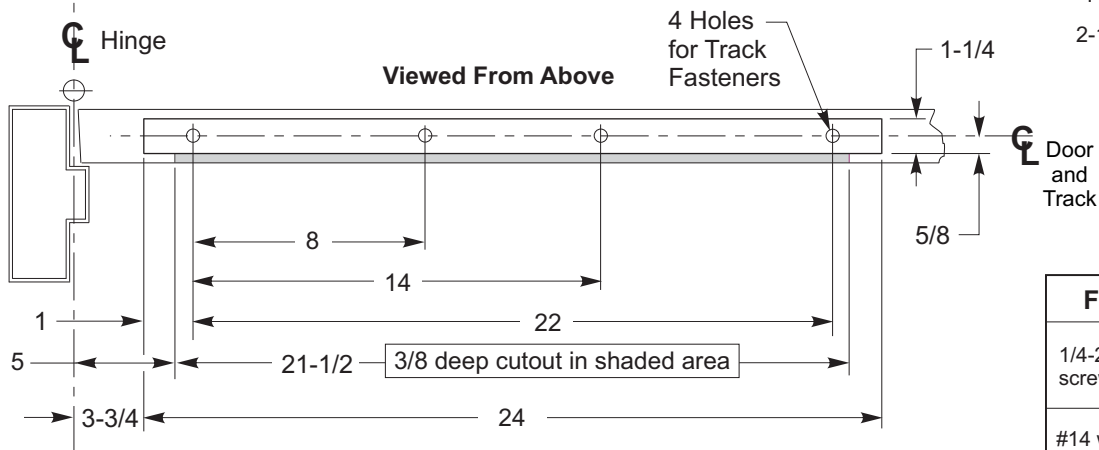
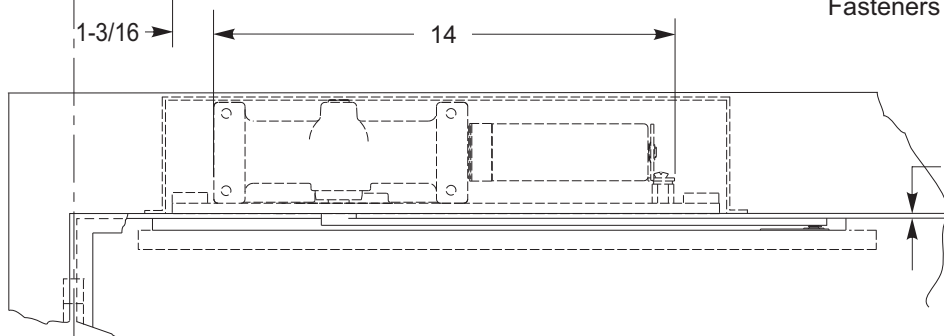

NOTES:

- Do not scale drawing.
- Left hand door shown.
- Hardware dimensions shown (not cutout).
- Dimensions are in inches (see chart for metric conversion).
- Minimum thickness recommended for reinforcements in hollow metal doors and frames: .1046" (2.66mm.) unless otherwise noted.
- Minimum door width 29 inches.
- Track is 24 inches long.
- Maximum width hinge is 5 inches.

METRIC CONVERSION CHART	
Inches	mm.
1/8	3.2
1/4	6.4
3/8	9.5
5/8	15.9
1	25.4
1-3/16	30.2
1-1/4	31.8
1-3/4	44.5
2	50.8
2-1/4	57.2
3-3/4	95.3
5	127.0
8	203.2
14	355.6
15-3/4	400.0
16-7/16	417.5
21-1/2	546.1
24	609.6
29	736.6

Fastener	Use	Preparation
1/4-20 machine screw	metal frame and metal door	#7 (.201" dia.) or 5.10mm. drill 1/4-20 tap
#14 wood screw	wood door	7/32" or 5.5mm. drill

7900H-B Series Door Closers
For Use on Doors Hung on 4-1/2" or 5" Wide Butt Hinges
Hold Open Installation



TEMPLATE NUMBER	REV	DATE
7379-0253	3	12/21