

Opening	Dimension "A"
To 100°	7-1/2 (191)
101° to 130°	6 (152)
131° to *180°	4-1/2 (114)

\*Door/Wall/Hardware/Jamb conditions permitting

**Notes:**

1. Do not scale drawing.
2. Right hand door shown.
3. Dimensions given in inches (millimeters).
4. Hollow metal doors require channel or box type reinforcement when thru-bolt mount is specified.
5. Sex bolts required for wood or plastic faced fire door mounting.
6. Minimum thickness recommended for reinforcements in hollow metal doors and frames: .1046" (2.66mm) unless otherwise noted.

**Position of Arm and Pinion Flat**

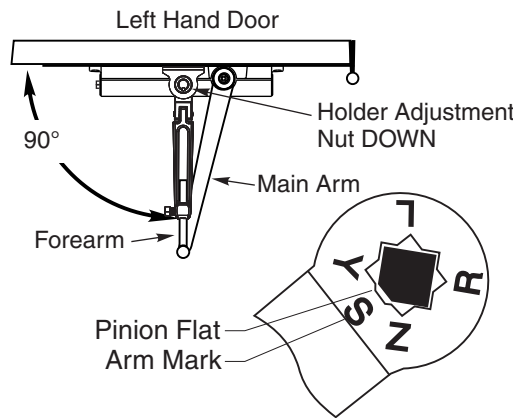
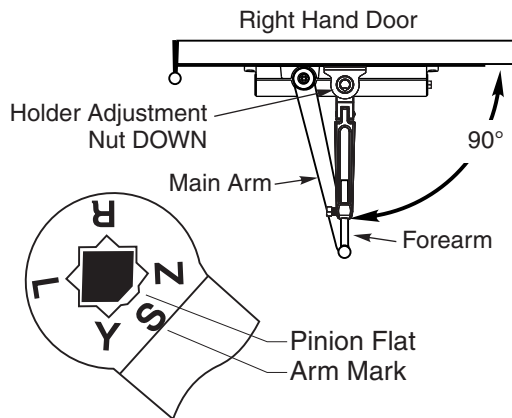

**8000H Series Door Closer  
 Regular Hold Open Application With 8146 Back Plate for 1-3/4 Top Rail  
 8100H, 8300H, and 8500H**



TEMPLATE NUMBER	REV	DATE
<b>7380-0108</b>	<b>3</b>	<b>01/22</b>