

Position of Arm and Pinion Flat

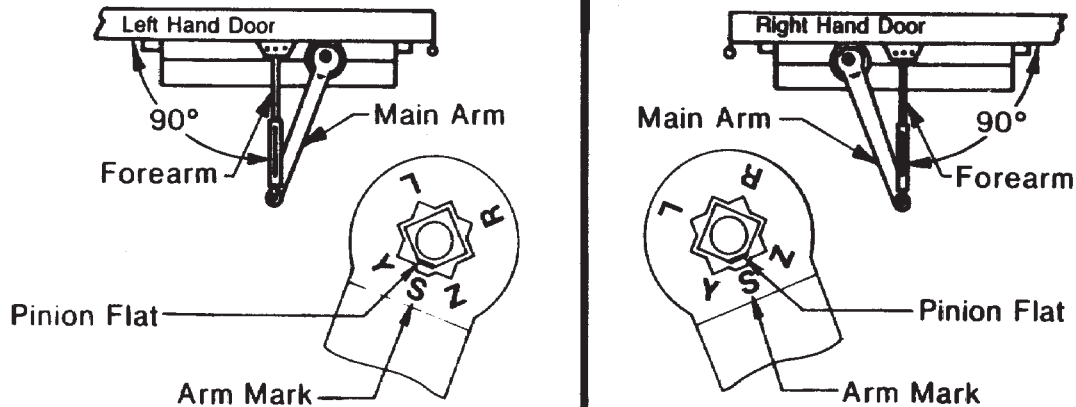

- Do not scale drawing.
- Right hand door shown.
- Dimensions are in inches (mm.).
- Hollow metal doors require channel or box type reinforcement when thru bolt mount is specified.
- Sex bolts required for wood or plastic faced fire door mounting.
- Minimum thickness recommended for reinforcements in hollow metal doors and frames: .1046" (2.66 mm.) unless otherwise noted.

8000 Series Door Closer
Regular Arm Application With 8146 Back Plate for Concealed Holder Clearance
8100, 8300, and 8500
Sizes 1 Thru 6



TEMPLATE NUMBER	REV	DATE
7380-0102	3	12/21