

IMPORTANT: From centerline of pivot point to end of track is 26½" (673 mm)

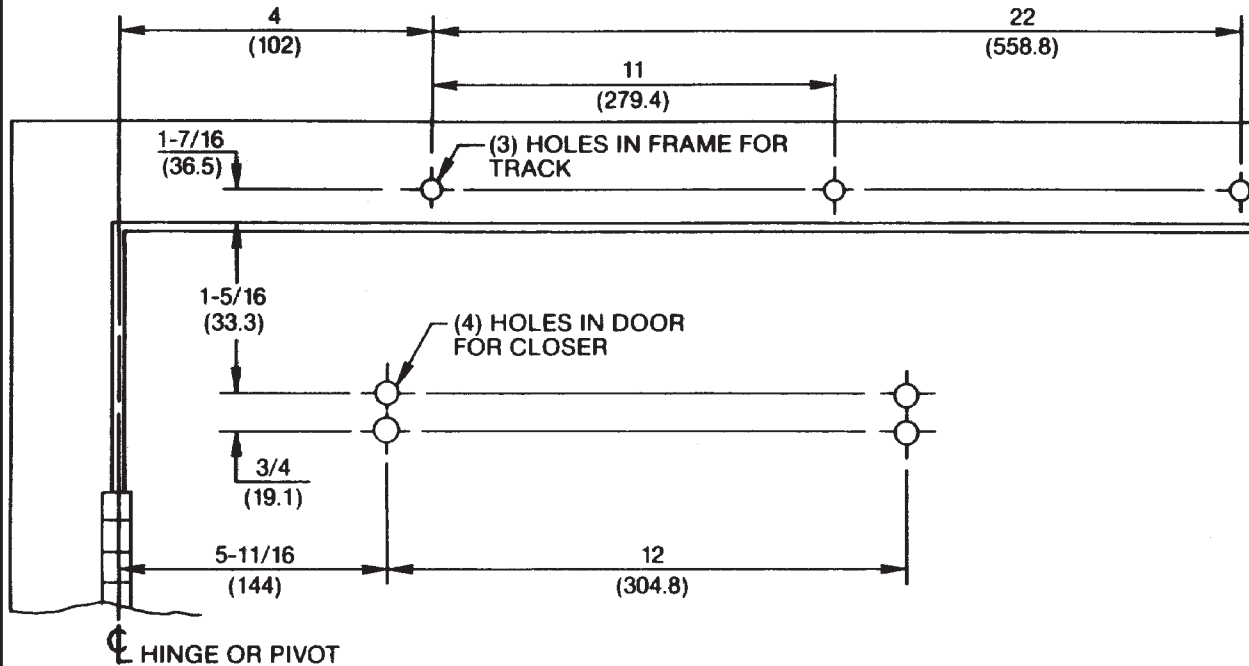

- Right hand door shown.
- Do not scale drawing.
- Dimensions are given in inches (mm.).
- Minimum ceiling clearance for unit is 2" (50mm.).
- Maximum door opening:
 - Non Hold Open with Spring Buffer - 110°
 - Non Hold Open without Spring Buffer - 180°
 - Hold Open - 110°

Preparation for Fasteners

| Fasteners | Door or Frame | Drill-Sizes |
|--|------------------|---|
| #14 type "A" S.M. screw | Wood | 3/16" (4.30mm.) |
| ¼"-20 machine-screw | Metal | drill: #7 (.201") tap: ¼"-20 |
| Sex-nuts and bolts (Optional) | Hollow-Metal | 9/32" (7.00mm.) through; 3/8" (9.50mm.) door-face opposite to closer |
| | Aluminum or Wood | 3/8" (9.50mm.) through |
| Through-bolt and grommet-nuts (Optional) | All | 9/32" (7.00mm.) through; 3/8" (9.50mm.) dia. x 3/8" (10mm.) deep door-face opposite to closer |

8300ST/8500ST Series Non Hold Open Door Closers
8300ST-H/8500ST-H Series Hold Open Door Closers
Hinge Side Slide Track Application



ASSA ABLOY

| | | |
|------------------|----------|--------------|
| TEMPLATE NUMBER | REV | DATE |
| 7380-0501 | 3 | 12/21 |