

Opening	Dimension "A"	
	inches	mm.
To 100°	7-1/2	191
100° to 130°	6	152
Over 130°	4-1/2	114

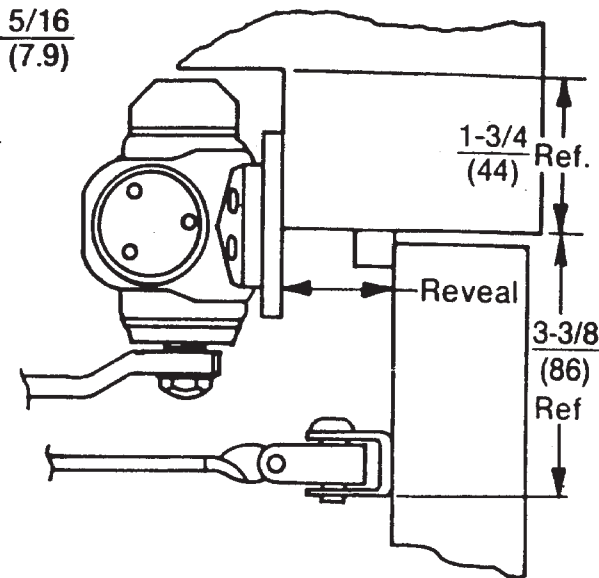

Position of Arm and Pinion Flat

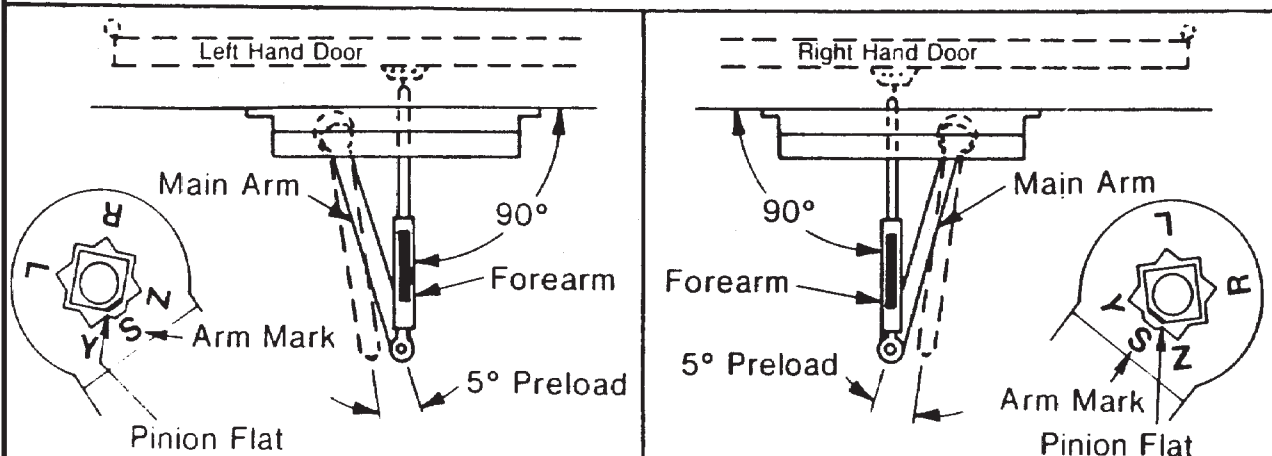

- Do not scale drawing.
- Left hand door shown.
- Dimensions are in inches (mm.).
- Hollow metal doors require channel or box type reinforcement when thru bolt mount is specified.
- Sex bolts required for wood or plastic faced fire door mounting.
- Minimum thickness recommended for reinforcements in hollow metal doors and frames: .1046" (2.66 mm.) unless otherwise noted.
- Use regular length rod for reveals to 3" (76 mm.). Use long rod for reveals 2-3/4" (70 mm.) to 6-3/4" (171 mm.).

**J8000 Series Door Closer**  
**Top Jamb Application With 8146 Back Plate for Low Ceiling Clearance**  
**J8100, J8300, and J8500**  
**Sizes 1 thru 6**



**ASSA ABLOY**

TEMPLATE NUMBER	REV	DATE
<b>7380-0151</b>	<b>3</b>	<b>12/21</b>