

Opening	Dim. "A" inch (mm)	Dim. "B" inch (mm)
To 120°	9-1/2 (241)	3-3/4 (95)
Over 120°	7 (178)	1-1/4 (32)

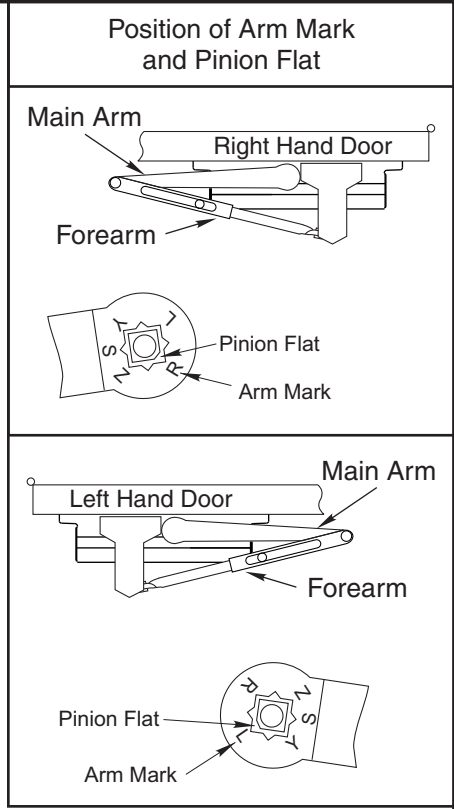

- Do not scale drawing.
- Left hand door shown.
- Dimensions are in inches (mm).
- Hollow metal doors require channel or box type reinforcement when thru bolt mount is specified.
- Sex bolt required for wood or plastic faced fire door mounting.
- Minimum thickness recommended for reinforcements in hollow metal doors and frames: .1046 (2.66mm) unless otherwise noted.

**P8000 Series Door Closer**  
**Parallel Arm Application With or Without 8148 Drop Plate**  
**P8100, P8300, and P8500 Sizes 1 Thru 6**

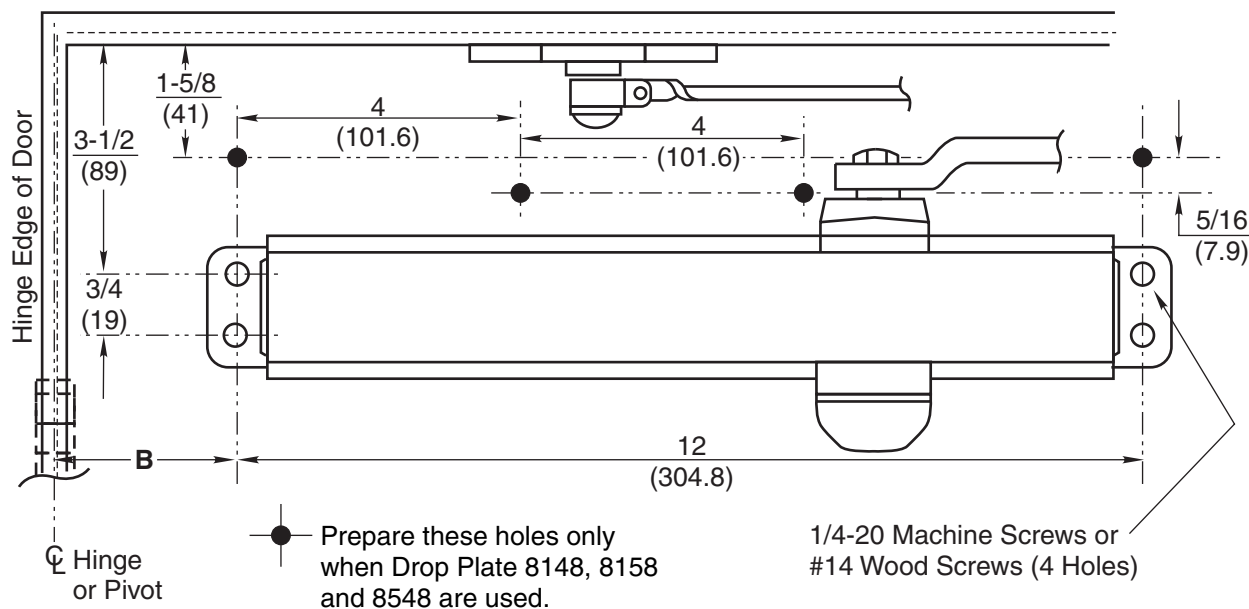

**ASSA ABLOY**

TEMPLATE NUMBER	REV	DATE
<b>7380-0201</b>	<b>3</b>	<b>12/21</b>