

WIRING DIAGRAM

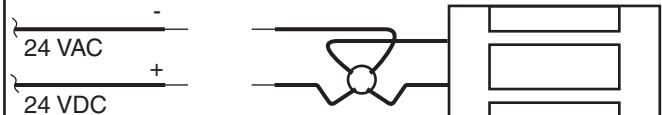

CAUTION: Nicks and scratches on the magnet surface will lessen or diminish the holding force of the magnet. Do not remove protective cap, if present, until last steps of installation.

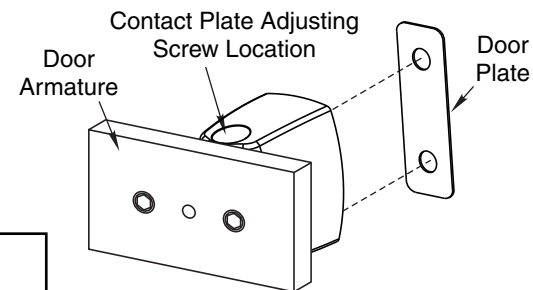

Thru Bolt Mounting

Notes:

1. Do not scale drawing.
2. Total projection 8-3/16". (Includes Electromagnet, Armature Assembly and Floor Bracket.)
3. Power requirements: 24VAC/DC, .25 amp.
4. See Step 1 on sheet 2 for Electric Box location. Anchor Electric Box to withstand a minimum 300 lb. pull.
5. Door closing mechanism should have a 3 lb. closing force at the degree of door opening where door armature and electromagnet engage.
6. All dimensions given in inches (mm).
8. See sheet 2 for more details.

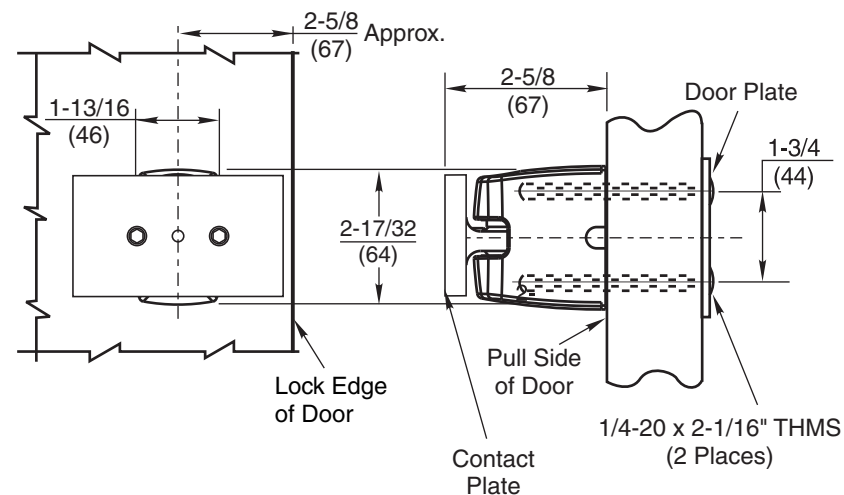
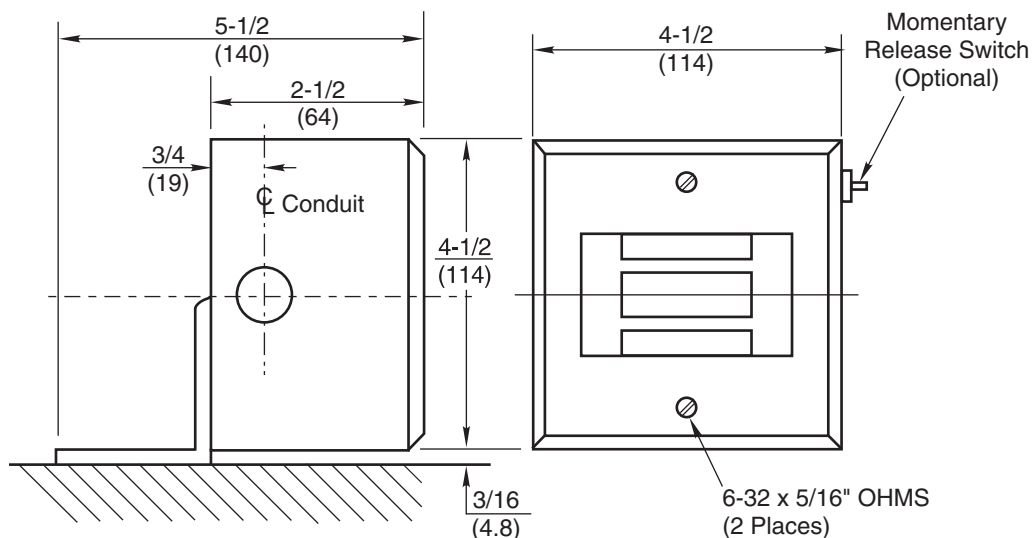

9930M Floor Mounted Door Release



ASSA ABLOY

TEMPLATE NUMBER	SHEET	REV	DATE
DR100245	1 of 2	3	06/22

Mounting Floor Portion

1. Locate angle bracket.
2. Attach bracket to floor with three (3) 1/4-20x1-1/2" FHPMS and three (3) 1/4-20 cement anchors.
3. Mount Electric Box to bracket using three (3) 1/4-20x1/2" RHMS.
4. Connect wire leads from power source to wire leads from magnet, and push wires back into Electric Box.
5. Mount magnet assembly to Electric Box using four (4) 6-32x5/16" FHMS.
6. Mount cover to magnet assembly using two (2) 6-32x5/16" OHMS.

Mounting Door Portion

1. **IMPORTANT:** Door portion must be installed with mounting holes in vertical position.
2. Contact plate adjusting screw must be loose to allow contact plate to swing freely.
3. Remove paper liner on adhesive surface exposing marking template beneath.
NOTE: Template must remain on armature.
4. With electromagnet energized, position contact plate to cover entire magnet surface. If magnet can not be energized, hold contact plate against magnet manually. Open door to engage door armature and exert pressure. Release door to close. Marking template will transfer to door. If necessary, align template securely to door.
5. Mark hole locations on door using centerlines on marking template. Drill two (2) 5/16" dia. holes through door on 1-1/4" centers.
6. Install door armature assembly to door. Must be mounted on pull side of door. Slot in contact plate adjusting screw must be accessible after mounting.

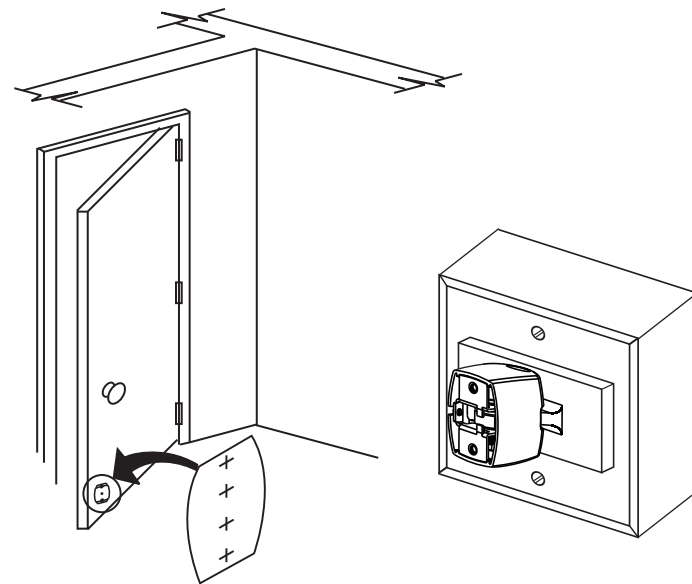

9930M Floor Mounted Door Release

NR NORTON
RIXSON

ASSA ABLOY

TEMPLATE NUMBER	SHEET	REV	DATE
DR100245	2 of 2	3	06/22

Approved 2022-06-16