

**Notes:**

1. Do not scale drawing.
2. Dimensions are given in inches (mm).
3. Right hand shown.
4. Machine Screw Size #12-24 x 3/4 FHMS  
Wood Screw Size #12 x 1-1/2 FHWS

**F519 Pocket Pivot**

**RIXSON**

**ASSA ABLOY**

www.rixson.com

TEMPLATE	REV	SHEET	DATE
IS-F519	3	1 of 2	10-21

# F519 Pocket Pivot Installation Instructions

- A. Using information below, prepare door and jamb for appropriate number of pivots based on door height and weight.
- B. Open pivot to expose screw holes. Using appropriate fasteners, attach smaller door portion of all pivots to door.
- C. Hang door by supporting door at the appropriate height within opening and sliding toward jamb so that pivots enter the jamb pockets and mortises.
- D. With door properly supported and opened to expose screw holes, attach pivot jamb portion of all pivots to jamb using appropriate fasteners.

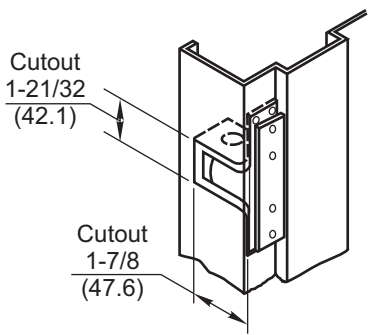

**Right Hand Frame  
(Jamb Style 1)**

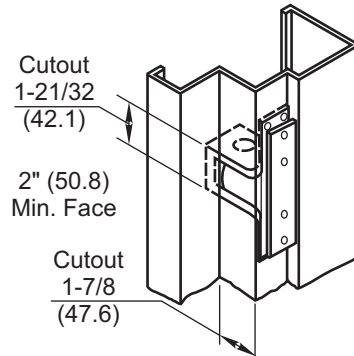

**Right Hand Frame  
(Jamb Style 2)**

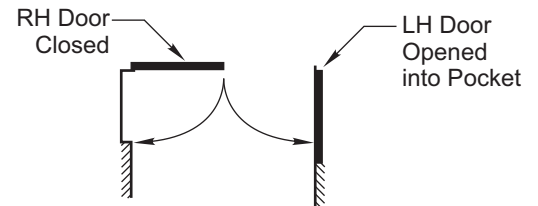

**Key Plan  
Pair of Doors**

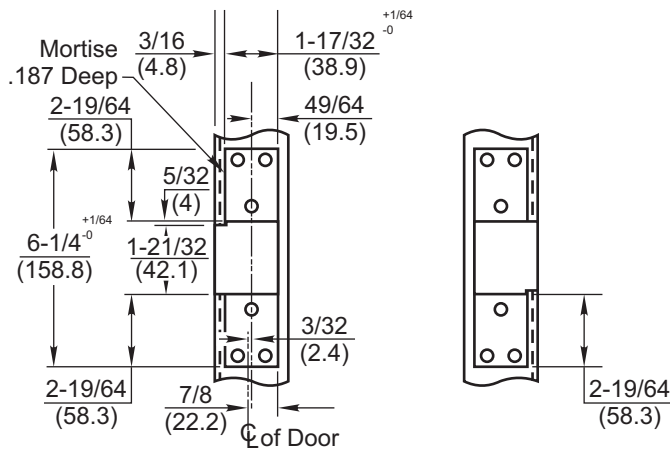

**Right Hand  
Left Hand  
Mortise Detail, Steel Frame**

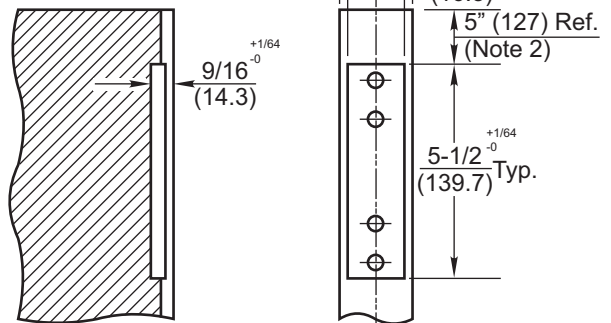

**Wood Application Shown  
Dimensions Same for Steel Door**

**Door Mortise Detail**

**Notes:**

- \* Prepare full length of door to these dims.
- Use standard spacing to suit size of door.
- Use 1 pivot for every 30" (762mm) of door height.
- Use 1 pivot for every 90 lbs. of door weight.
- Reinforcement tabs shall leave clear opening of 1-7/8 to allow installation of pivot.

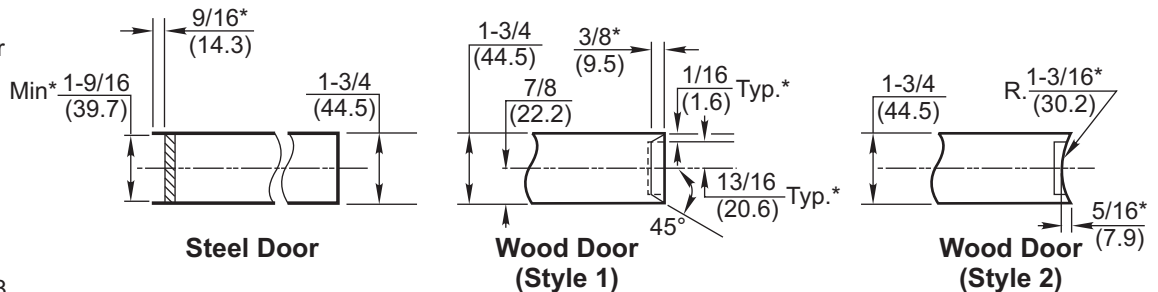

**Door Jamb Clearance 7/64 (2.8) - Hinge Side**

**F519 Pocket Pivot**

**RIXSON**

**ASSA ABLOY**

www.rixson.com

TEMPLATE	REV	SHEET	DATE
IS-F519	3	2 of 2	10-21