

NOTE: For door thickness not listed, use next size smaller for preparation.

Door Size	A	B	Max. Lead Thk.
1-3/4 (44.5)	1-1/4 (31.8)	1/4 (6.4)	9/32 (7.1)
2 (50.8)	1-3/8 (34.9)	5/16 (7.9)	3/8 (9.5)
2-1/4 (57.2)	1-1/2 (38.1)	3/8 (9.5)	15/32 (11.9)
2-1/2 (63.5)	1-5/8 (41.3)	7/16 (11.1)	9/16 (14.3)
3 (76.2)	2 (50.8)	1/2 (12.7)	3/4 (19)

Table above is based on the assumption that lead is placed in center of door.

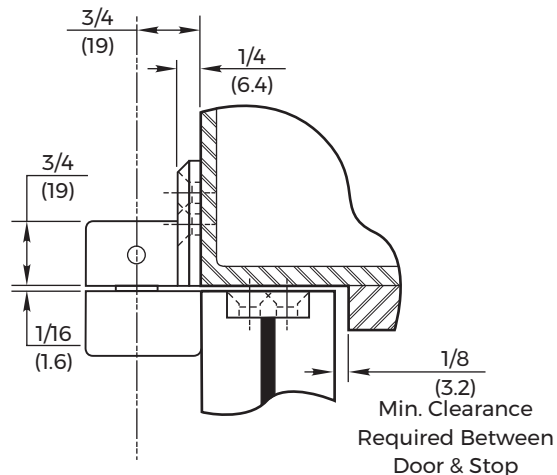
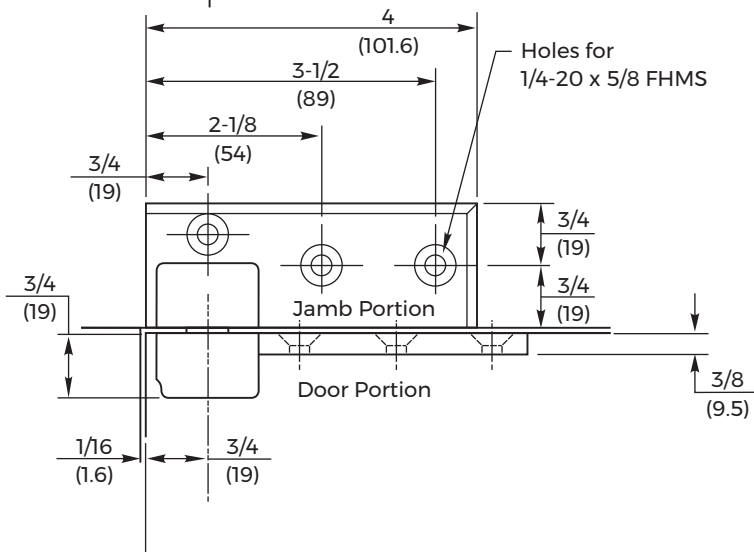
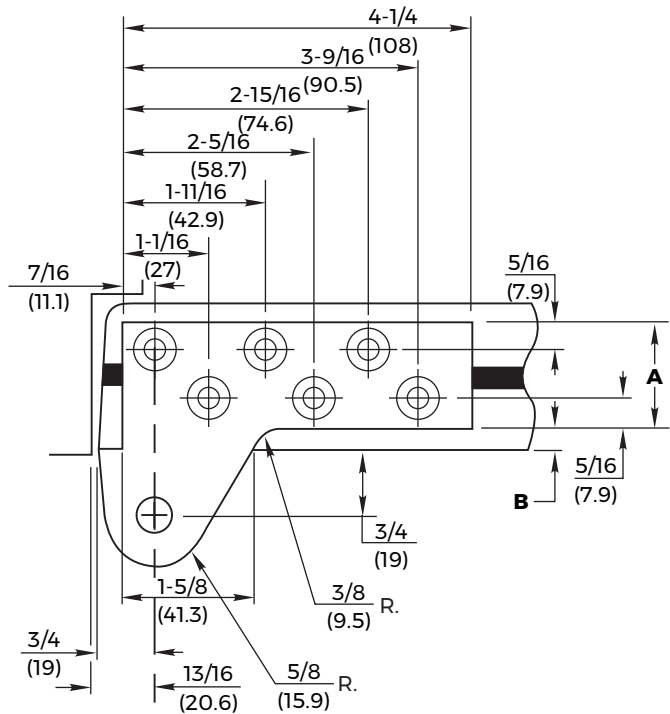

Installation Instructions:

1. All lead furnished by others.
2. 1/8" (3.2) minimum clearance required between door and stop.
3. Pivot knuckle centers must be in line with top pivot and closer spindle centers or else binding will result.
4. Top jamb portion drilled for 5/8" x 1/4"-20 FHAS with Nylok portion patch (provided).
5. Top door portion drilled for 2" x 14 FHWS or 1" x 1/4"-20 FHMS.
6. 500 lb. maximum door weight limitation when used with "L" type floor closer or pivot set and side jamb pivot.

NOTES:

1. Do not scale drawing.
2. Dimensions are given in inches (mm).
3. Right Hand shown.
4. Template drawing for reference only.

**L380 Top Pivot, Half Mortise
 Heavy Duty
 (Jamb Portion Surface Applied)
 For Lead Lined or Extra Large Doors**

Approved 2024-06-06



TEMPLATE NUMBER	REV	DATE
IS-L380	3	05/24

L380 Top Pivot

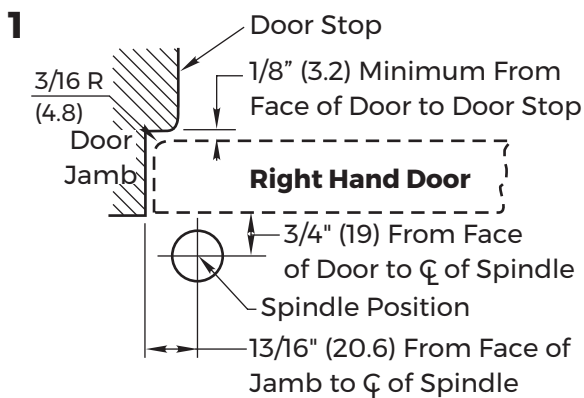

1. Install Pivot

- Measure 13/16" (20.6) out from door jamb.
- Allow 1/8" (3.2) min. clearance from door stop to door face. Measure door thickness. Add 3/4" (19).
- Where lines meet determines center line of closer/bottom pivot.

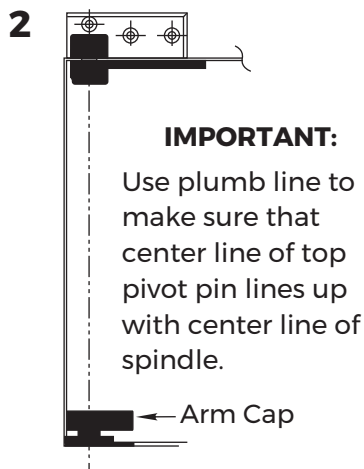

2. Install Top Pivot & Arm

- Install top pivot in door per template.
- Install top pivot in frame per template.

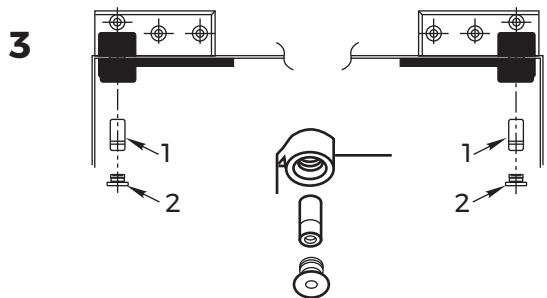

3. Hang Door

- Set door on bottom pivot/closer spindle.
- Push Item 1 "top pivot pin" into place. Attach "cap" Item 2. CAP MUST BE TIGHTENED SECURELY

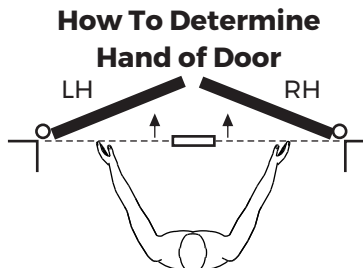

Face a door swinging open away from you. If it opens to the right, it is right hand. If it opens to the left, it is left hand.

**L380 Top Pivot, Half Mortise
 Heavy Duty
 (Jamb Portion Surface Applied)
 For Lead Lined or Extra Large Doors**



TEMPLATE NUMBER	REV	DATE
IS-L380	3	05/24