

RIXSON®

ASSA ABLOY

CAUTION AN INCORRECTLY INSTALLED OR IMPROPERLY ADJUSTED DOOR CLOSER CAN CAUSE PROPERTY DAMAGE OR PERSONAL INJURY. THESE INSTALLATION INSTRUCTIONS SHOULD BE FOLLOWED TO AVOID THE POSSIBILITY OF MISAPPLICATION OR MISADJUSTMENT.

Installation Instructions

80-9372-0085-015 (02-09)

Support Unit Models

4 PUSH

Selective Multipoint Hold Open

Double Lever Arm

Stop (push) side of door mounting

Combination Door Closer-Holder and Releasing Device Signaled by External Detection Equipment

All dimensions shown are in inches and (millimeters) unless otherwise noted.

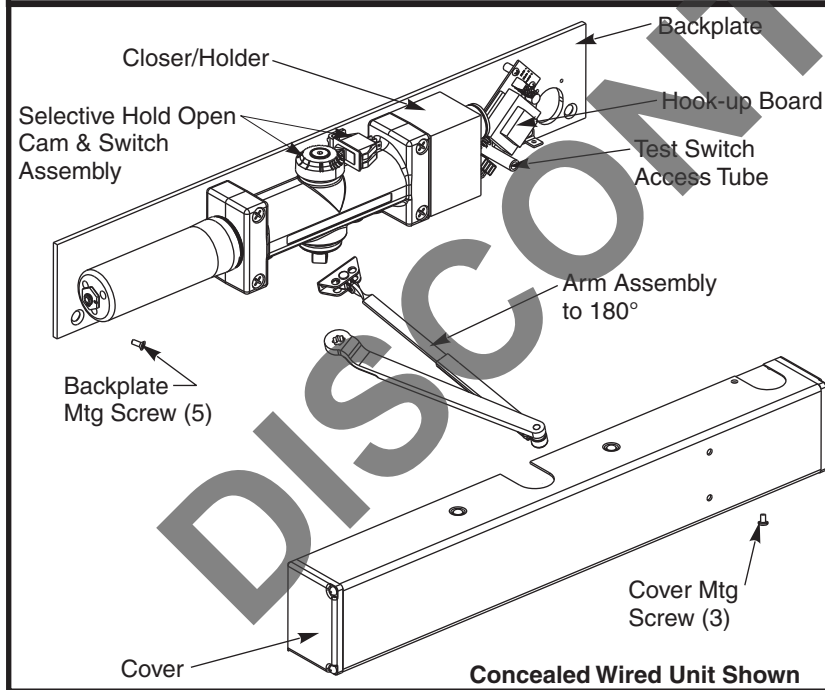
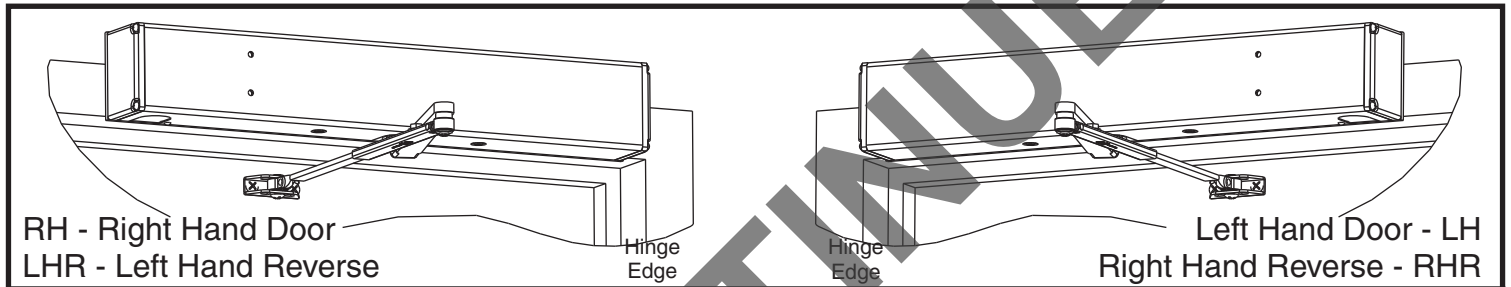
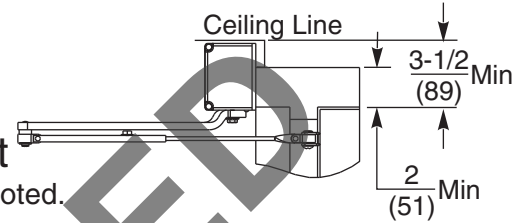

Preparation for Fasteners			
	Fasteners	Door or Frame	Drill-Sizes
Standard	1/4" - 20 machine screw	Metal	Drill: #7 (0.201" dia.) Tap: 1/4" - 20
	Sleeve nuts and bolts	Hollow Metal	9/32" (7 mm) through; 3/8" (9.5 mm) door face opposite to closer
Aluminum or Wood		3/8" (9.5 mm) through	
Optional	Through-bolts and grommet-nuts	All	9/32" (7 mm); 3/8" (9.5 mm) dia. x 3/8" (9.5 mm) deep on door opposite to closer

Use of an auxiliary door stop, by others, is required.

Requirements:

- Units are handed. Hand of unit and hand of door must be the same.
- Door must be hung on butt hinges or 3/4" (19) offset pivots.
- Door thickness must be 1 3/4" (44) minimum 2 1/4" (64) maximum.
- Door must swing freely through the entire opening and closing cycle before beginning the installation procedure.
- Frame face must be a minimum of 2" (51).
- Ceiling clearance must be a minimum of 4" (102).
- Power input to unit must be of the same voltage as that stated on the unit.
- Unit to be mounted on interior of building in dry environment, maximum humidity of 95%.
- See NFPA70 for wiring requirements and NFPA72 for alarm system requirements.

NOTE: For special applications a separate door and frame preparation template is packed with these instructions. Use this instruction sheet for installation sequence and closer adjustments only.

1 Determine Hand

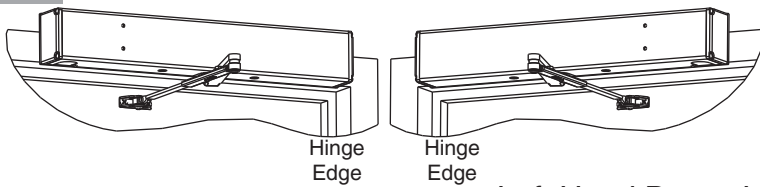

RH - Right Hand Door LH - Left Hand Door
 LHR - Left Hand Reverse RHR - Right Hand Reverse

DOOR OPENING ANGLE	Dimension "A"	
	Inches	(mm)
To 100°	5-7/8	150
100° to 180°	3-1/8	80

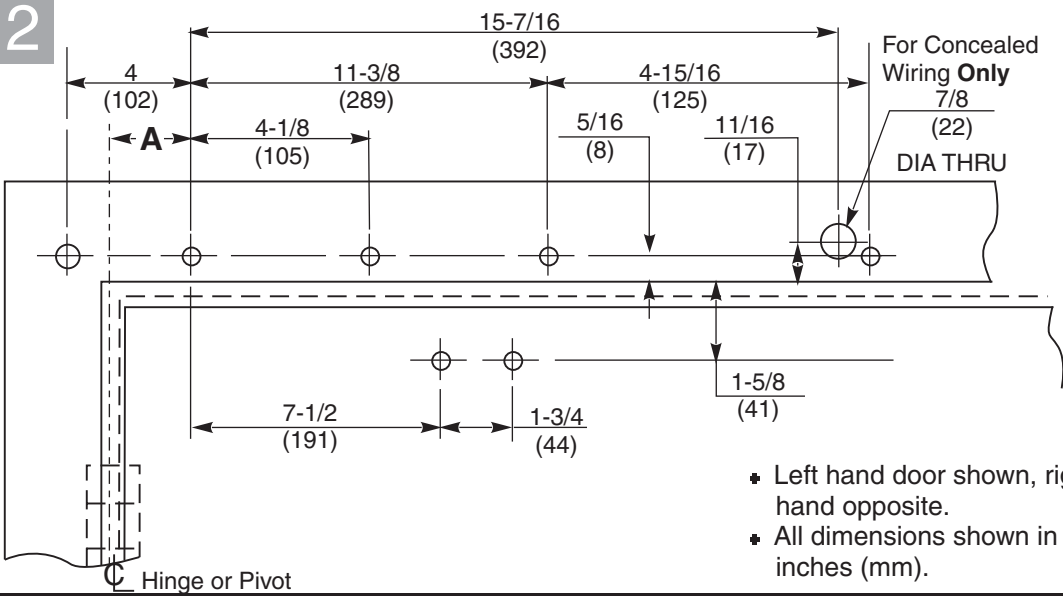

- Left hand door shown, right hand opposite.
- All dimensions shown in inches (mm).

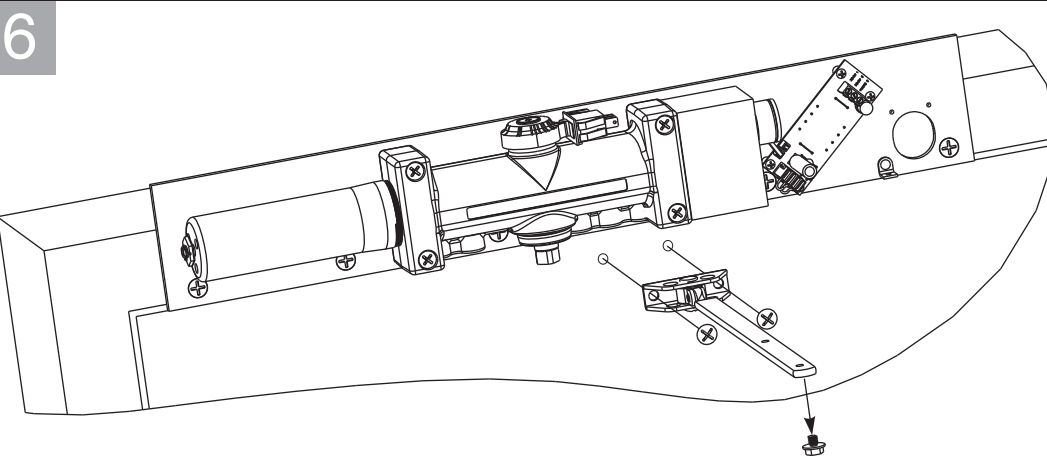
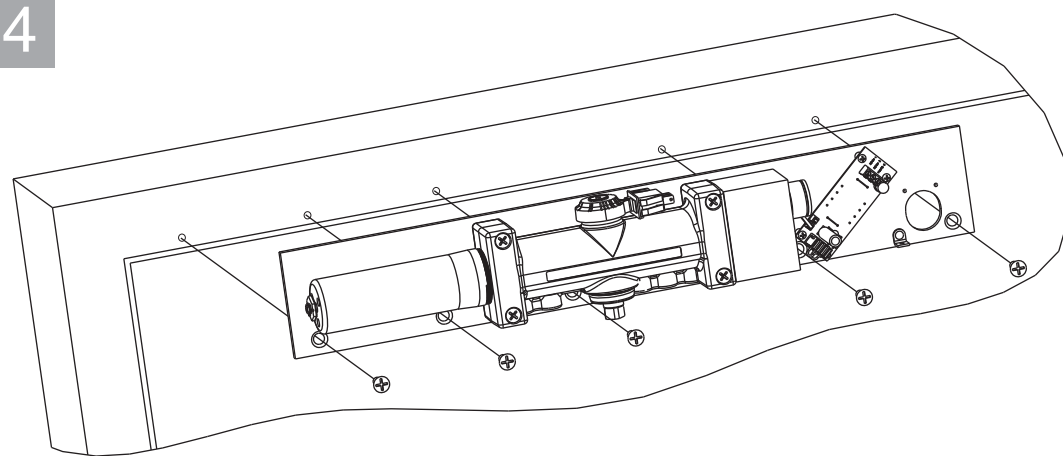
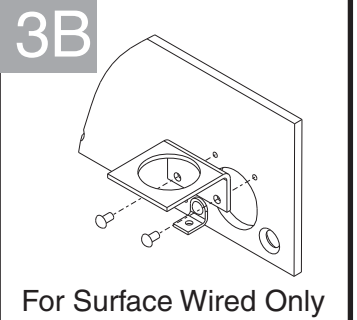
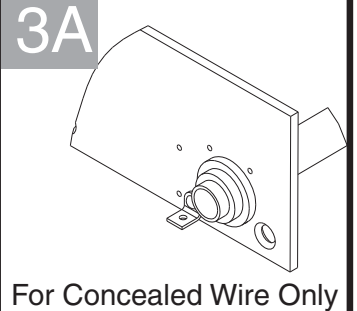

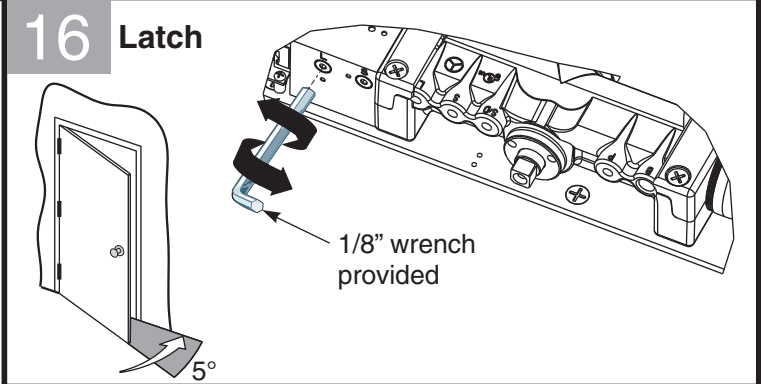
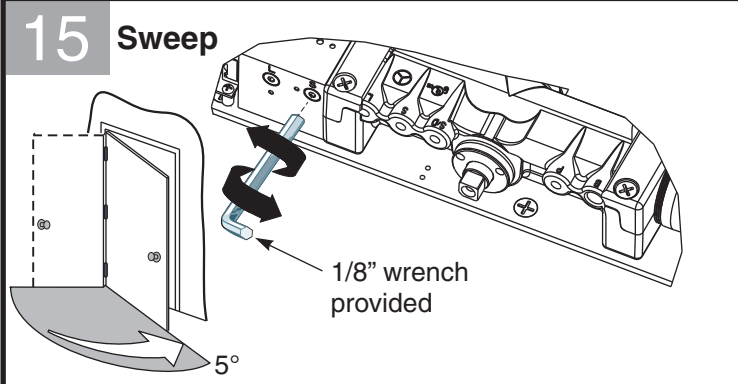
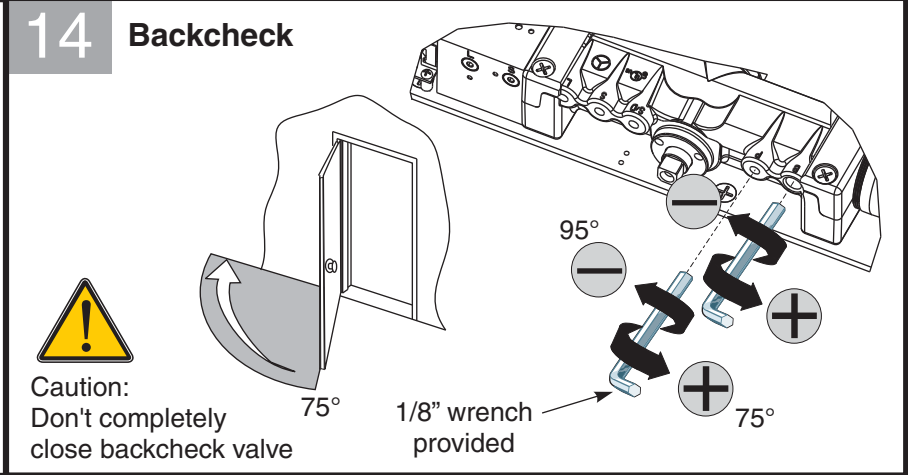
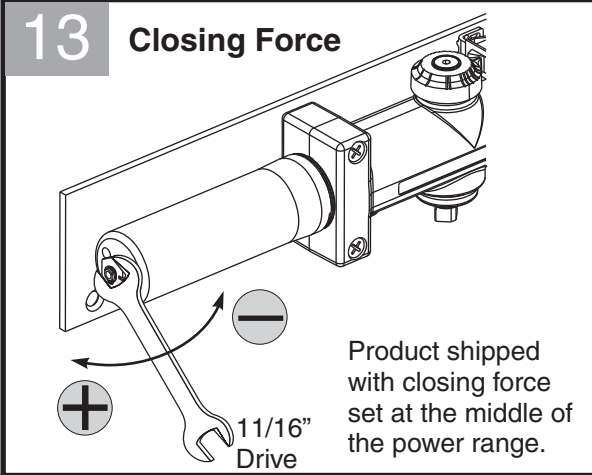
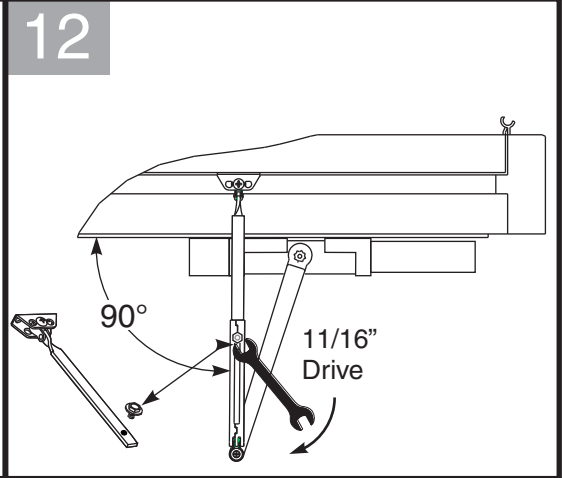
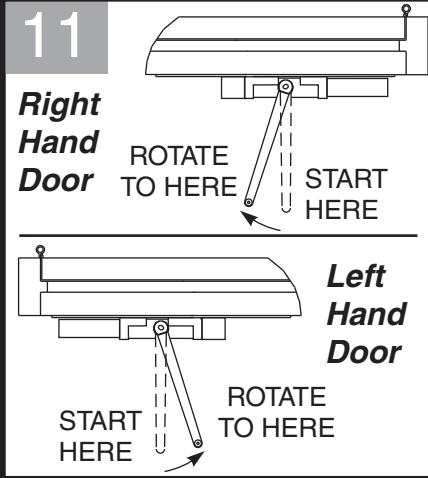
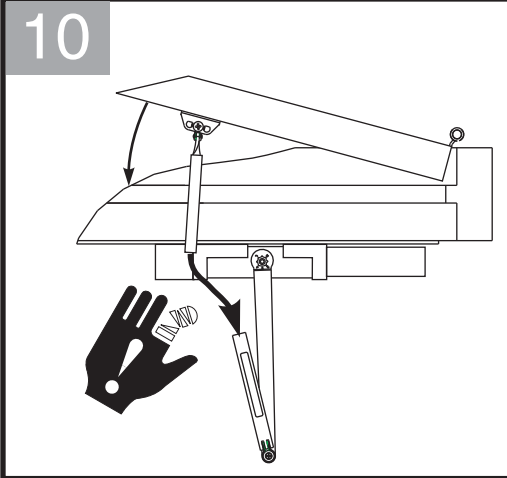
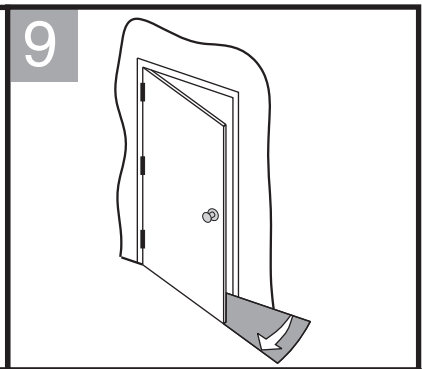
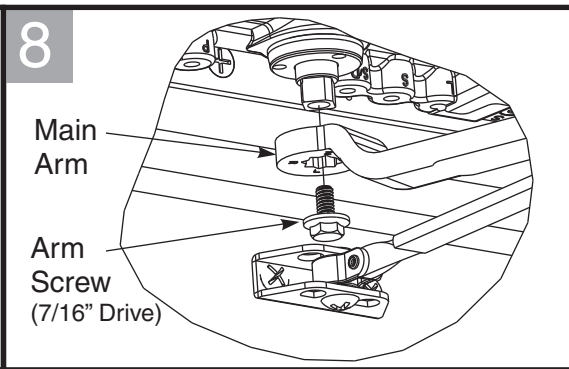
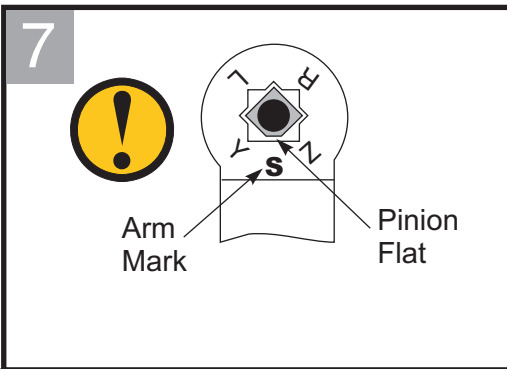

17 MAKE ELECTRICAL CONNECTIONS:

- Power input to unit must be of the same voltage as that listed on the label.
- All wiring connections use standard wiring practice
- Maximum wire size is 18AWG.
- Make input power connections to the hook-up board terminal strip using illustrations and wiring diagrams on Page 4.

24V AC/DC INPUT CIRCUIT BOARD

(shown with 4-pin jumper for non-detected units)

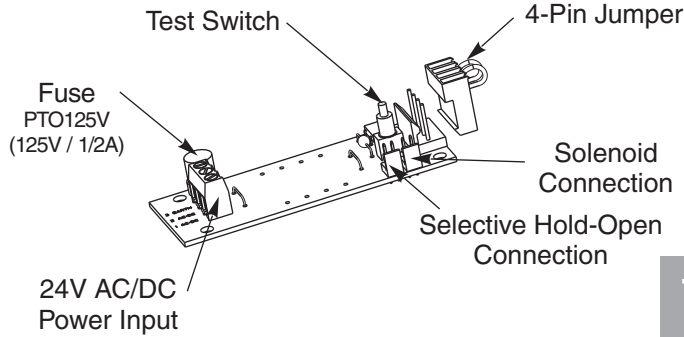

120V AC INPUT CIRCUIT BOARD

(shown with 4-pin jumper for non-detected units)

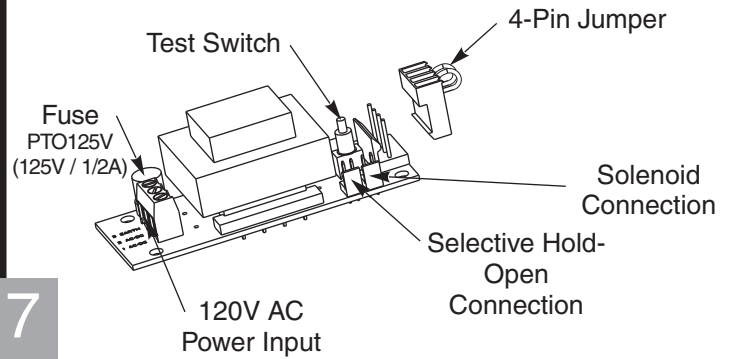

17
cont

Support Unit Wiring Diagram (24VAC/DC Input)

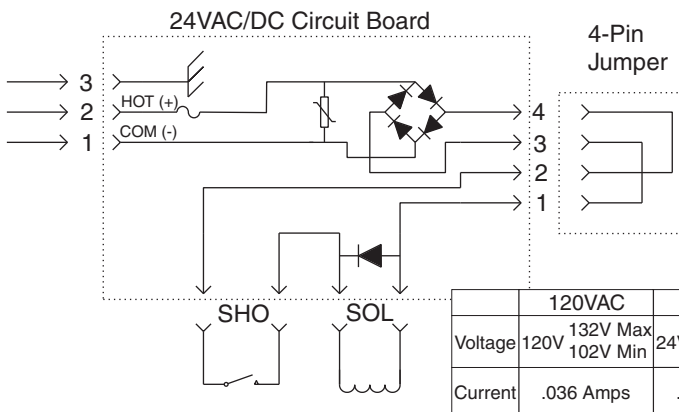

Support Unit Wiring Diagram (120VAC Input)

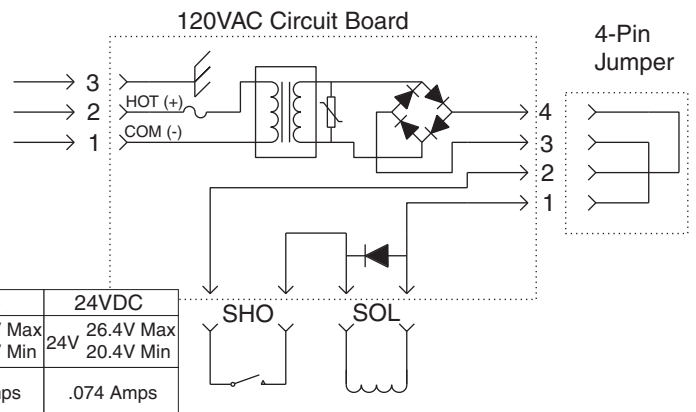

	120VAC	24VAC	24VDC
Voltage	120V 132V Max 102V Min	24V 26.4V Max 20.4V Min	24V 26.4V Max 20.4V Min
Current	.036 Amps	.059 Amps	.074 Amps

18

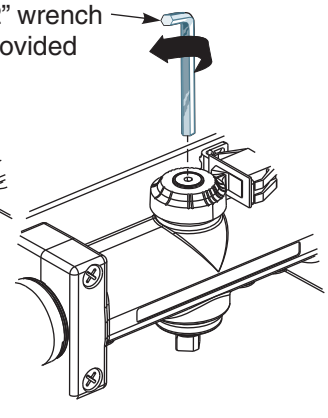
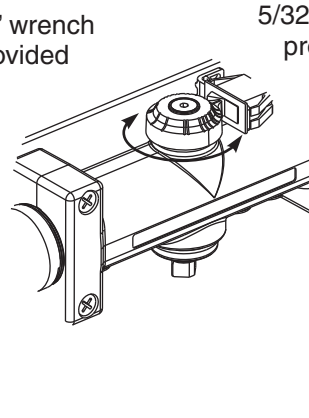
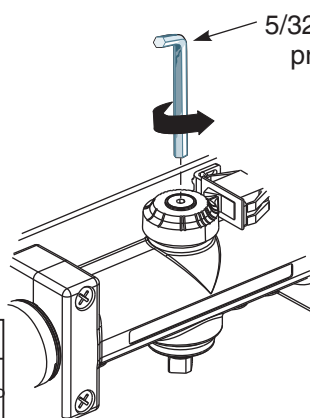
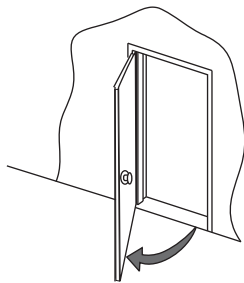

Setting	G	H	J	K	L	M
Door Angle	15°	30°	45°	60°	90°	135°

Selective Hold Open Range

These units feature hold open (as shipped) starting at 85°. These units will hold open at virtually any degree of door opening from 85° to 180°. The hold open starting point may be changed (increased or decreased) by loosening the selective hold open cam screw, rotating the cam to the desired new starting point and re-tightening the cam screw.

19

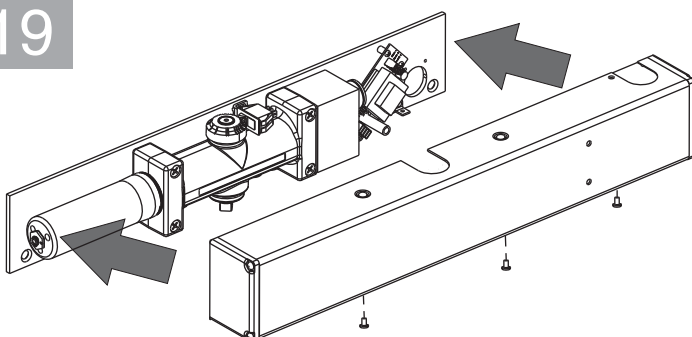

Rixson® is a registered trademark of Yale Security Inc., an ASSA ABLOY Group company. Copyright © 2009 Yale Security Inc., an ASSA ABLOY Group company. All rights reserved. Reproduction in whole or in part without the express written permission of Yale Security Inc. is prohibited.

RIXSON®

ASSA ABLOY

ASSA ABLOY, the global leader in door opening solutions

3000 Highway 74 East • Monroe, NC 28112

Tel: (800)-457-5670

www.rixson.com