

Offset Pivot Set INSTALLATION INSTRUCTIONS

**OP-2700:
FLUSH DOOR**

**OP-2800:
1/8" RECESSED DOOR**

1. Drill or drill and countersink holes in door and frame as shown.
2. Rout out header and notch threshold as shown.
3. Install frame portion using (3) #12-24 X 3/4" flat head machine screws.
4. Install top and bottom door portions securing each with (2) 5/16" X 8 X 1/2" hex head cap screws with washers.
5. Install floor portion using (2) #12 X 1-1/4" plastic expansion plugs and (2) #12 X 1-1/4" flat head all-purpose screws.
6. To install door, place bottom door portion on stud of floor portion at a slight angle, depress pin in the top door portion and tilt door into opening until pin engages in frame portion.
7. Adjust door for proper clearance by turning adjustable pivot stud (loosen set screw before adjusting and retighten after).

NOTE: Right hand door shown, left hand opposite.

**HEADER & TOP DOOR PREPARATION
OP-2700 & OP-2800**

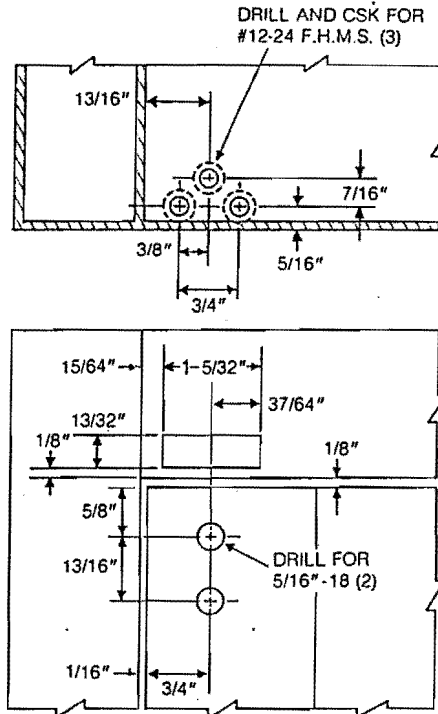

**FLOOR & THRESHOLD PREPARATION
OP-2700: FLUSH DOOR**

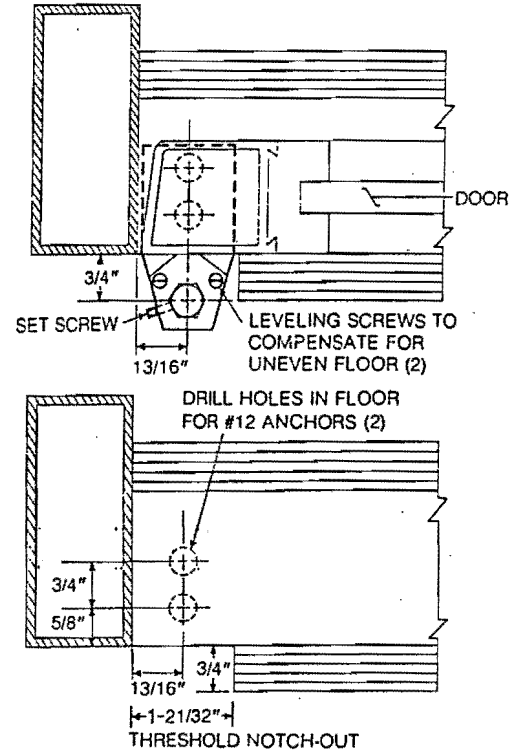

**BOTTOM DOOR PREPARATION
OP-2700 & OP-2800**

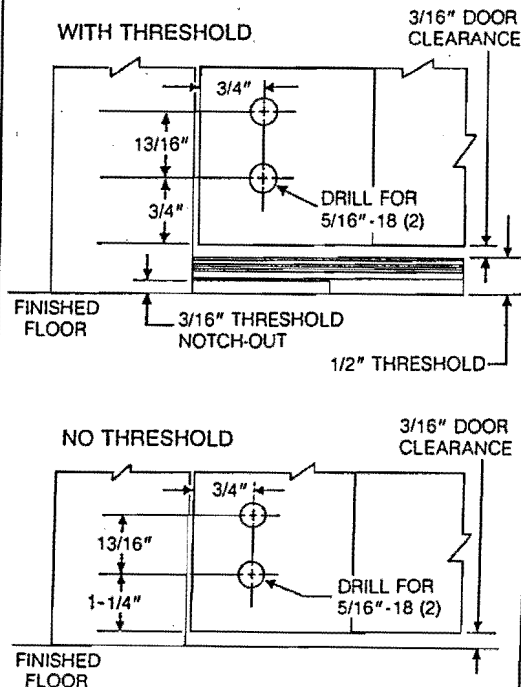

**FLOOR & THRESHOLD PREPARATION
OP-2800: 1/8" RECESSED DOOR**

