

Optional Cams

For DCP and DCP500
Padlockable Cam Locks

GENERAL SPECIFICATIONS

Use with: DCP and DCP500 padlockable cam locks.

Reversible: All bent cams are reversible and can be used in either the inbent or outbent position.

Standard cam: The DCP and DCP500 padlockable cam locks ship standard with DCP-LC (1-1/4" straight cam) pictured at the right.

Standard Cam

The DCP and DCP500 padlockable cam locks ship standard with the below 1-1/4" straight cam:

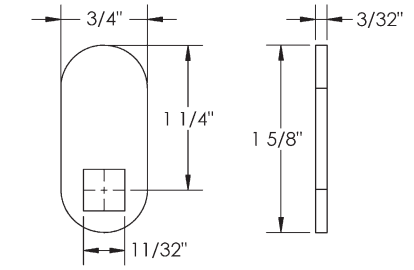

DCP-LC

OPTIONAL STRAIGHT CAMS

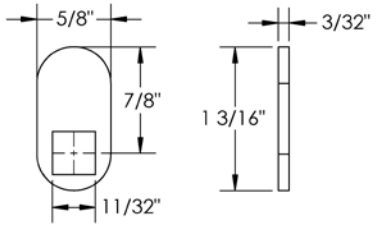

DCP-SC
7/8" straight cam

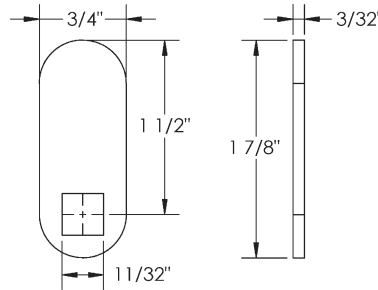

DCP-LC-112
1-1/2" straight cam

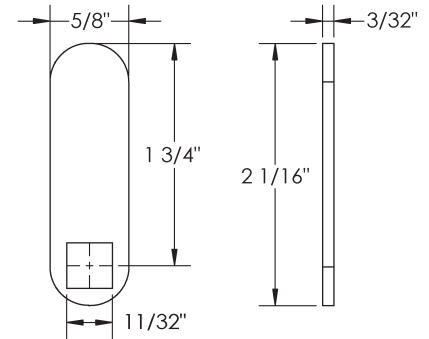

DCP-LC-134
1-3/4" straight cam

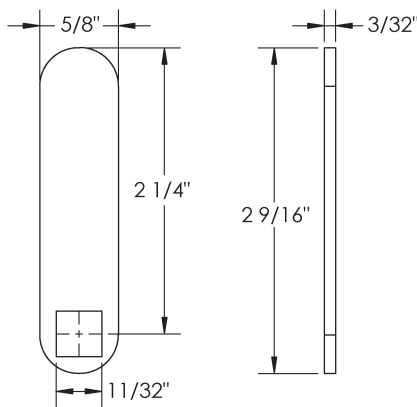

DCP-LC-225
2-1/4" straight cam

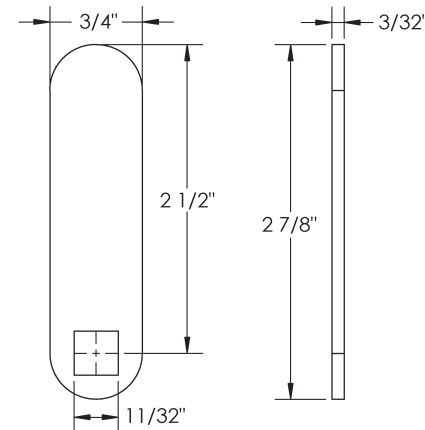

DCP-LC-250
2-1/2" straight cam

SEE REVERSE
FOR OPTIONAL
OFFSET CAMS



WARNING: This product can expose you to chemicals including chromium, which is known to the State of California to cause cancer and birth defects or other reproductive harm. For more information go to www.P65Warnings.ca.gov.



**OLYMPUS
LOCK**
INC

Optional Cams

For DCP and DCP500
Padlockable Cam Locks

OPTIONAL OFFSET CAMS

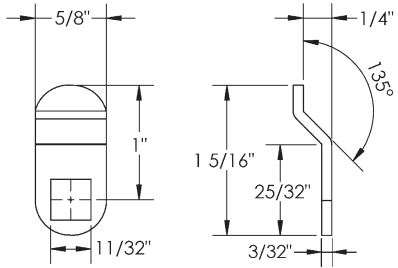

DCP-1-14
1" cam with 1/4" offset

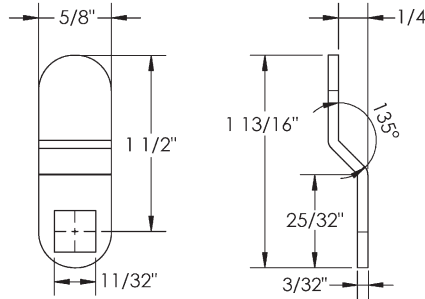

DCP-112-14
1-1/2" cam with 1/4" offset

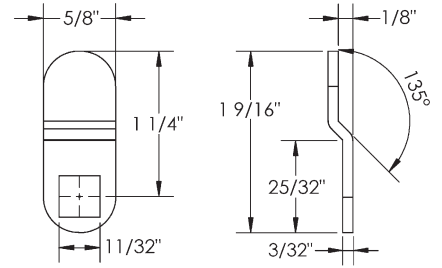

DCP-114-18
1-1/4" cam with 1/8" offset

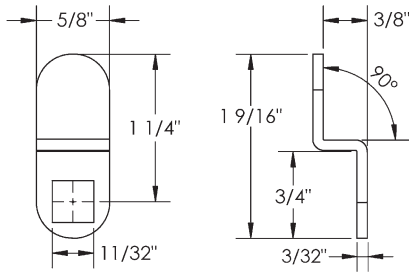

DCP-114-38
1-1/4" cam with 1/8" offset

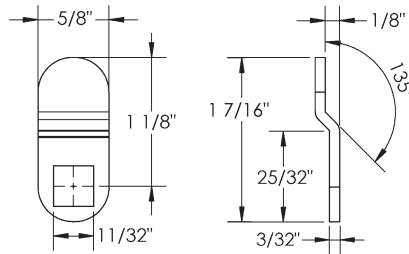

DCP-118-18
1-1/8" cam with 1/8" offset

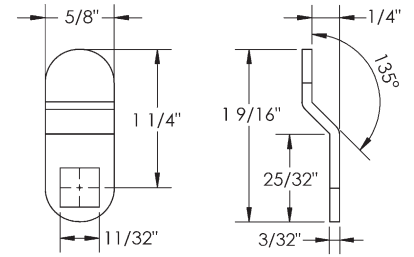

DCP-LBC
1-1/4" cam with 1/4" offset

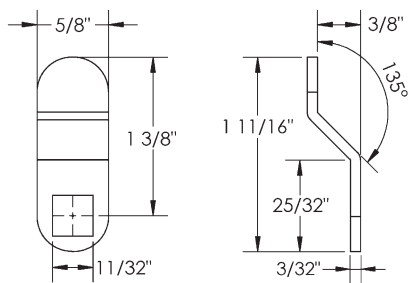

DCP-LBC-138
1-3/8" cam with 3/8" offset

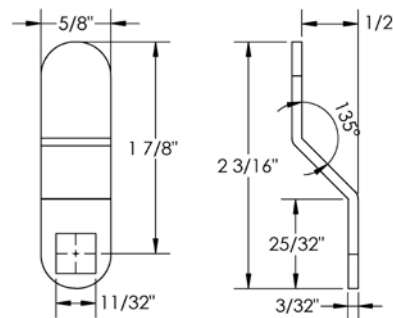

DCP-LBC-178
1-7/8" cam with 1/2" offset