

6300/6400 RAIL FILLER INSTALLATION

ALL DEVICES

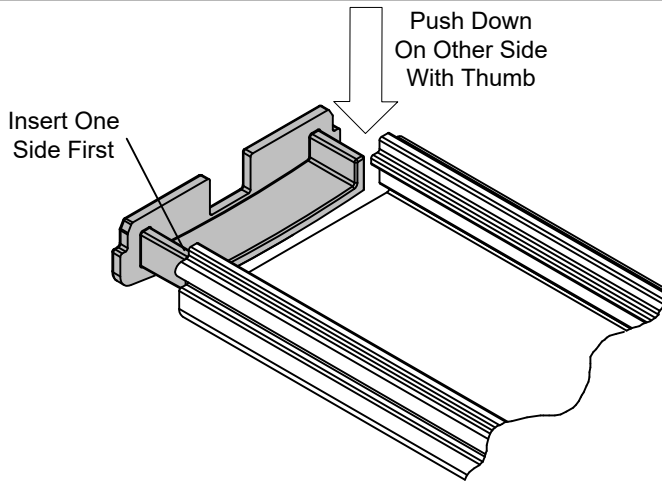

Phone: 833-2-PDQTEC | www.pdqlocks.com



1. INSERT FILLER CAP / RETAINER

- Insert one corner of Filler Cap into extrusion
- Filler cap is curved / spring-loaded and will not insert without pushing down on other side.
- Once both leading corners are engaged, push or tap cap into extrusion.

2. START FILLER

- Overlap plastic Filler Cap onto main rail extrusion being careful not to overlap extrusions.
- Put one side of filler down into extrusion.
- Push or tap other side to snap into place so filler will fit and slide into place.

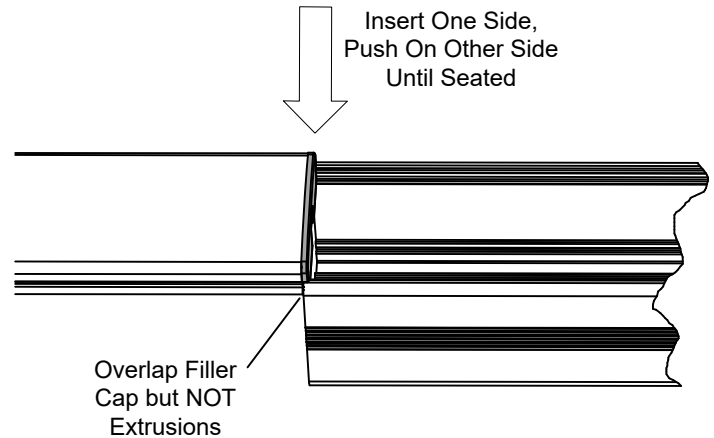

3. SLIDE FILLER INTO PLACE

- Slide filler and filler cap into place – proper position is flush with end of main rail.

