

6300M/MF EXIT INSTALLATION INSTRUCTION

MORTISE DEVICE

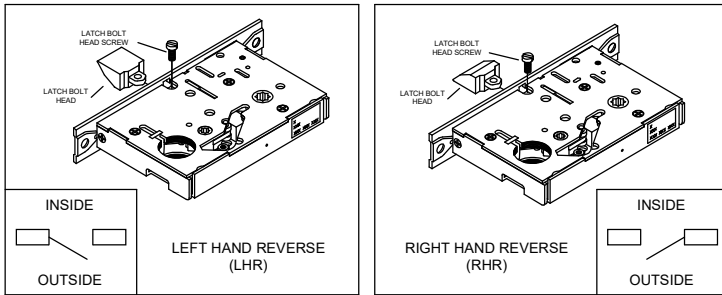

Phone: 833-2-PDQTEC | www.pdqlocks.com



1. MORTISE HANDING

- To re-hand mortise case, remove latch bolt screw as shown.
- Orient the latch bolt head to match handing.
- Reinsert and tighten the latch bolt screw.

2. DOOR PREPARATION

- Prepare the door for the mortise lock using the 6300M/MF template in box.
- Refer to trim template if installing trim.
- Install the mortise case and secure using two (2) #12-24 combo screws supplied in the hardware kit.

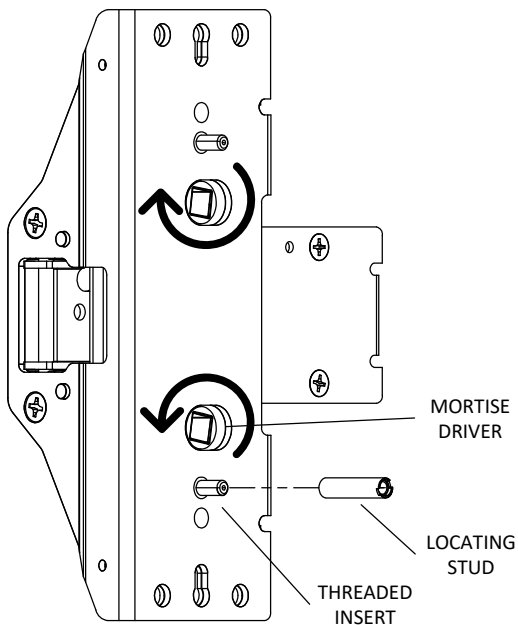
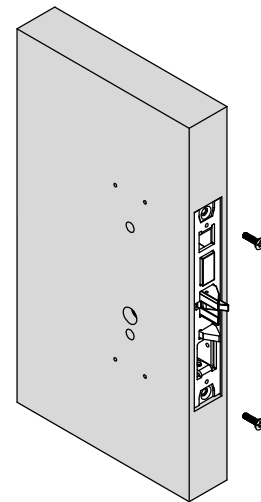

3. PREPARE DEVICE

- Install locating stud on lower threaded insert as determined by handing.
- Rotate lower mortise driver as shown until it stops. Make sure when installing that mortise driver remains in this position.

6300M/MF EXIT INSTALLATION INSTRUCTION

MORTISE DEVICE



4. SIZE DEVICE

- Standard lengths are for 36" or 48" door. Device must be cut for other lengths.
- Mark length with tape – length equals device size minus desired door size (for 30" door = cut 6" off 36" device) ensuring a square cut.

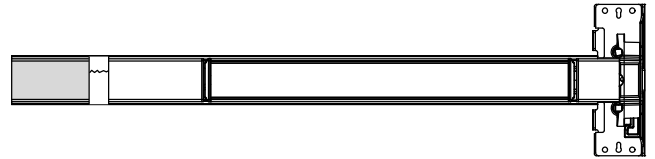

Maximum cut off length:				
	Panic	Fire	Alarm	MLR
36" Device	6"	8"	2"	3"
48" Device	12"	14"	8"	9"

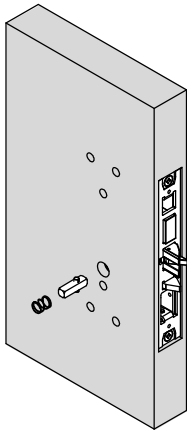

5. INSTALL DEVICE SPINDLE

- Install spindle and spring in orientation shown on push side of door.

6. INSTALL DEVICE

- Install device and trim with 1/4-20 screws from the hardware kit.
- Device can be surface mounted to the door, optional sex nuts are available, device is through bolted when using trim.

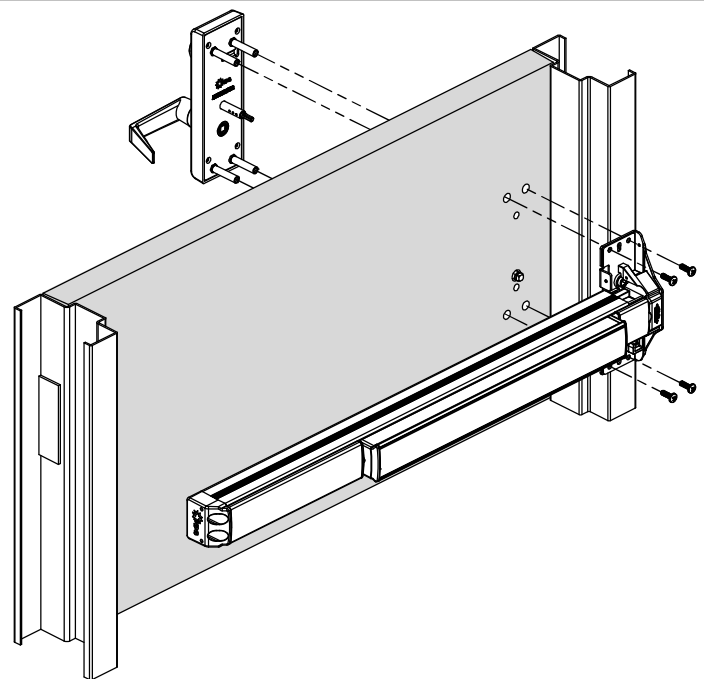

Mounting Options:

Reinforced Steel or Aluminum Door	Surface Mount: Drill/Tap push side for 1/4-20
Solid Wood Door	Drill 1/8" Pilot Hole for #10 Wood
All Others	Use optional Sex Bolts. Drill push side with 9/32" drill bit. Drill pull side with 3/8" drill bit.

6300M/MF EXIT INSTALLATION INSTRUCTION

MORTISE DEVICE



Phone: 833-2-PDQTEC | www.pdqlocks.com

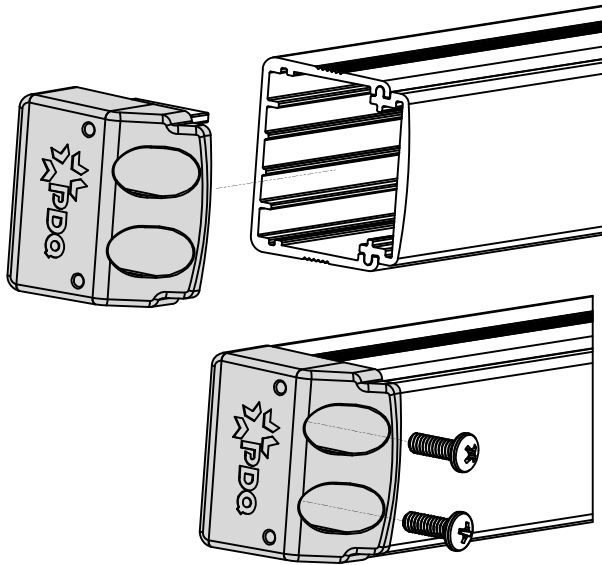

7. INSTALL END CAP

- Slide end cap into rail. Ensure rail is level. Mark the centers of the slots.
- Remove end cap then drill holes using the chart from Step 3.
- Reinstall end cap and fasten with screws.

8. INSTALL HEAD COVER

- Slide head cover onto exit device
- Install 4 mounting screws

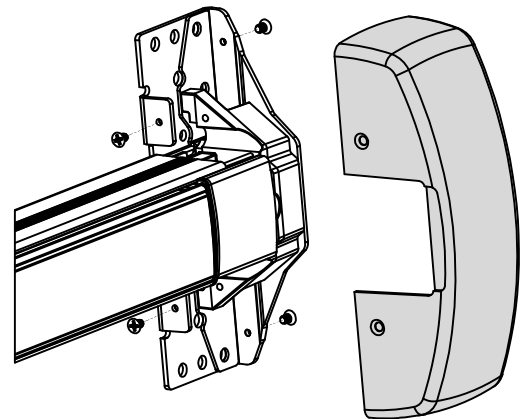

9. INSTALL STRIKE

- Install the strike and secure with two (2) #12-24 combo screws supplied in the strike screw pack.

