

6EWS pdqSMART INSTALLATION INSTRUCTION

EXIT DEVICE TRIM

ALL 6EWS – EXCLUDING STS



Phone: 866-874-3662 | www.pdqlocks.com

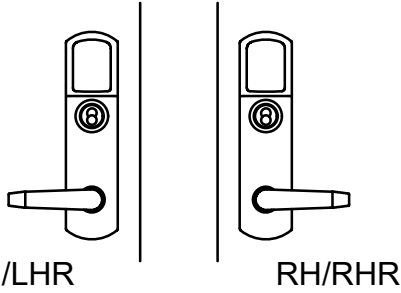

1. PREPARE TRIM FOR INSTALLATION

- Rotate lever to proper orientation for door, install square drive spindle into back of trim.

2. INSTALL TRIM AND EXIT DEVICE

- Prepare door according to included template.
- Install escutcheon trim onto door while feeding wires through door.
- Install exit device and secure with (4) included $\frac{1}{4}$ -20 x $\frac{3}{4}$ " pan head screws.
- Rim Device: Install chassis/head cover.
- SVR Device: Skip to step 4

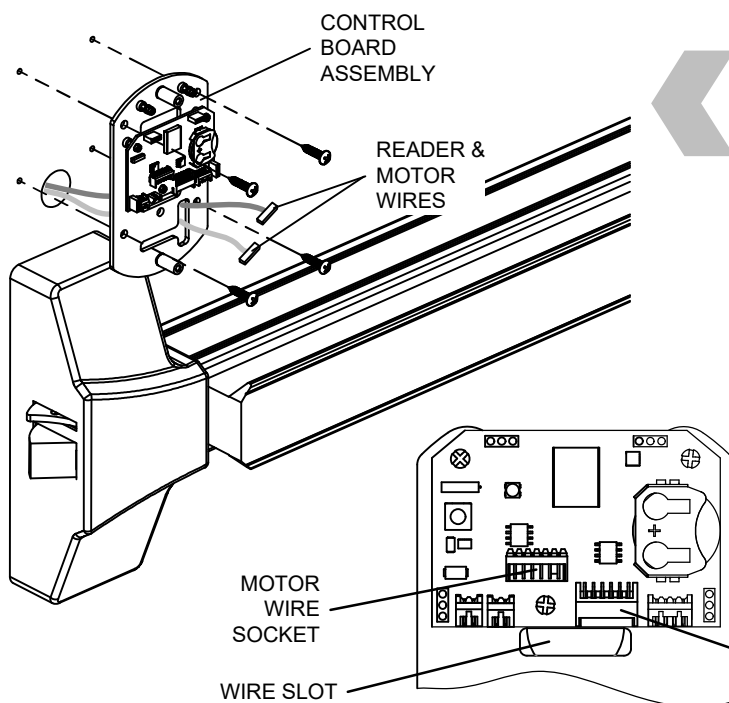
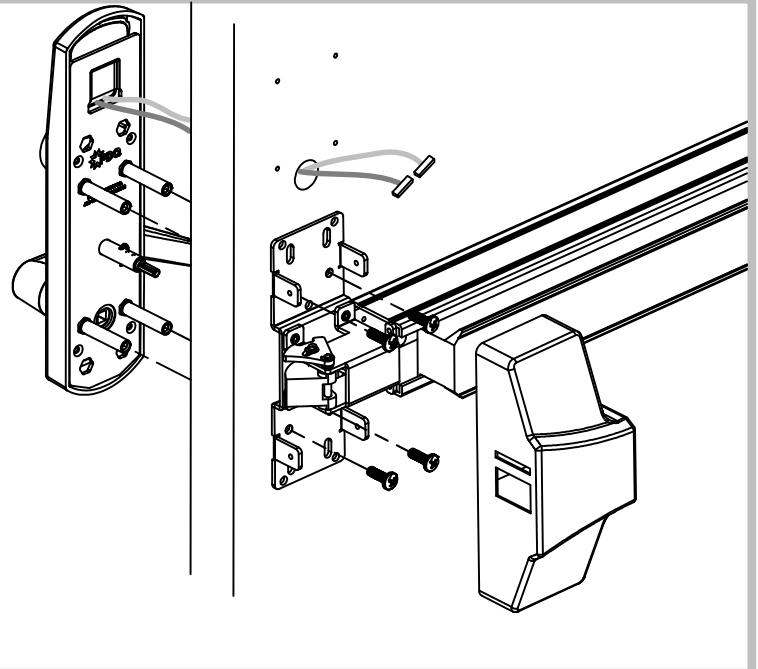

3. RIM DEVICE - INSTALL CONTROL BOARD

- Install control board assembly – feed wires through slot under circuit board.
- Secure assembly with (4) included wood/metal screws.
- Make wire connection after control board is installed. Push extra wire into door cavity.

6EWS pdqSMART INSTALLATION INSTRUCTION

EXIT DEVICE TRIM

ALL 6EWS – EXCLUDING STS



4. SVR DEVICE - INSTALL SPACER & CONTROL BOARD

- Install rod spacer block with (2) included wood/metal screws – feed wires through slot in block.
- Install top rod before control board.
- Install control board assembly – feed wires through slot under circuit board and secure assembly with (4) wood/metal screws.
- Make wire connections after control board installed. Push extra wire into door cavity.
- Install Chassis/Head cover

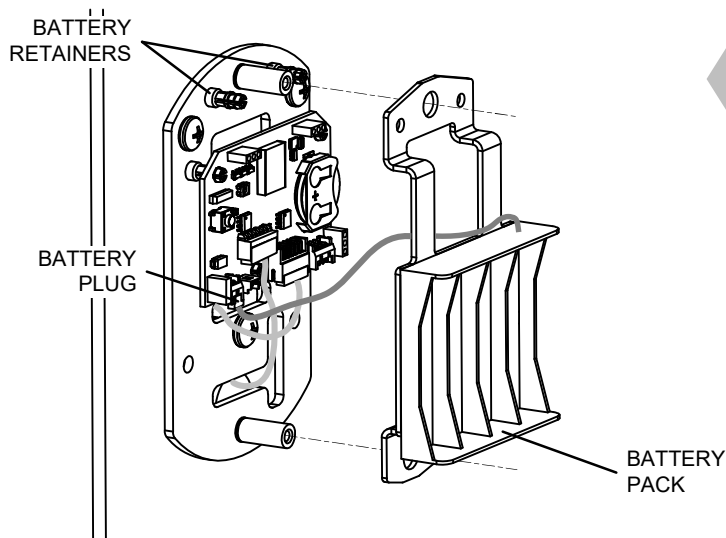
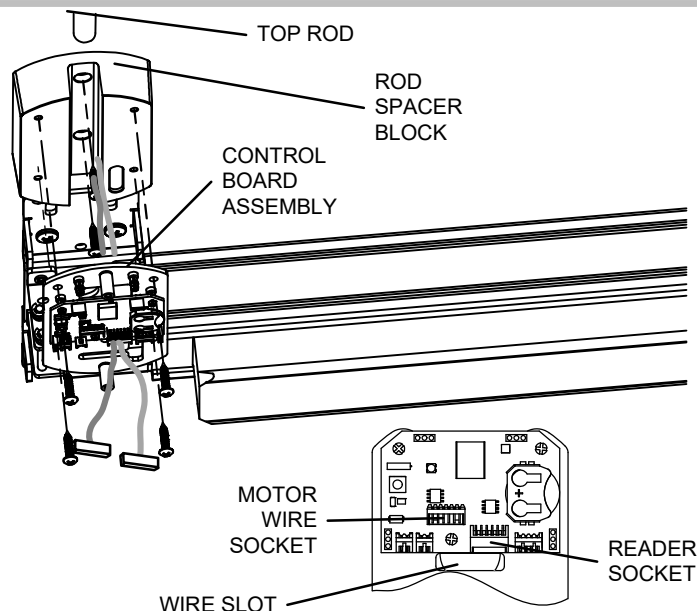

5. INSTALL BATTERY PACK

- Plug battery wire into control board.
- Install battery pack over two studs on mounting plate and snap battery pack onto retainers on control board assembly.

6. INSTALL BATTERIES AND BATTERY COVER

- Install batteries and battery cover with (2) #8-32 x 1" pan head screws.

