

7101 DOOR CLOSER MODELS

PARALLEL ARM INSTALLATION - PUSH SIDE
DS AND DSHO APPLICATIONS

TEMPLATE: 719304,
REV. 2 08-21-18

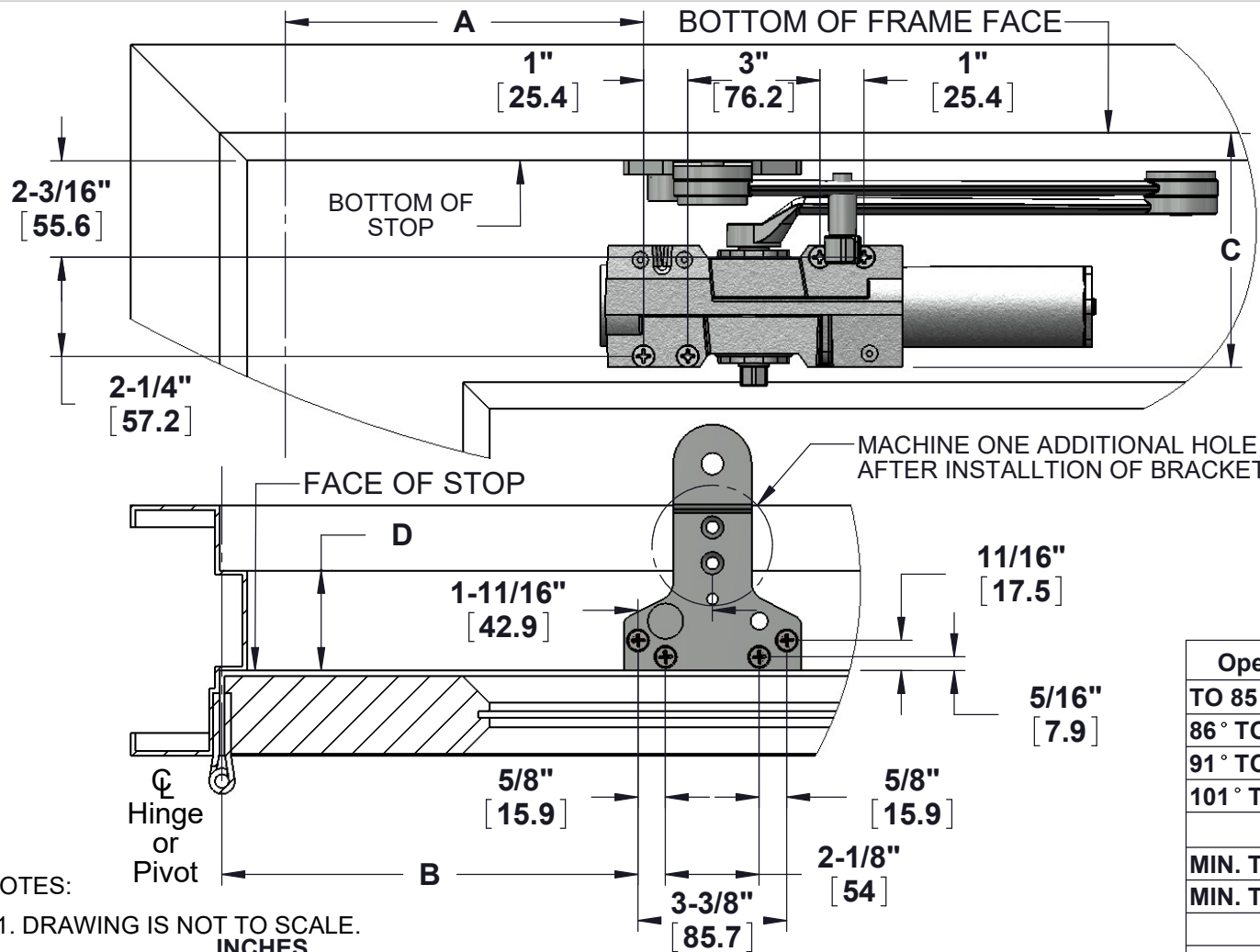

MACHINE SCREWS:
USE #7 OR 13/64" [5.1] DRILL AND 1/4-20 TAP

WOOD DOOR/FRAME SCREWS:
USE 5/32" [4] DRILL

SEX NUTS:
USE 3/8" [9.5] DRILL (CLOSER TO DOOR)

NOTES:

1. DRAWING IS NOT TO SCALE.
2. DIMENSIONS IN **INCHES** [MM]
3. LEFT HAND DOOR SHOWN. FOR RIGHT HAND DOOR REVERSE IMAGE.
4. DIMENSIONS BASED ON 4-1/2" X 4-1/2" BUTT HINGES.
5. MUST BE MOUNTED FOR 100° OR 110° OPENING TO MEET ADA REQUIREMENTS.
6. DOOR SWING MAY BE ALTERED DUE TO OTHER LIMITING CONDITIONS.
7. CAUTION: SEX NUTS MAY BE REQUIRED FOR UNREINFORCED DOORS OR COMPOSITE FIRE DOORS. CONSULT MANUFACTURER'S RECOMMENDATIONS.
8. HOLD OPEN ARMS CAN NOT BE USED ON LABELED FIRE DOORS.
9. ALWAYS CHECK PDQ WEBSITE FOR THE MOST RECENT REVISION AT WWW.PDQLOCKS.COM.

Opening**	Dim. A	Dim. B
TO 85°	9-1/2" [241.3]	9-1/2" [241.3]
86° TO 90°	8-3/4" [222.3]	8-3/4" [222.3]
91° TO 100°	7-5/8" [193.7]	7-5/8" [193.7]
101° TO 110°	6-5/8" [168.3]	6-5/8" [168.3]
Dim. C *		
MIN. TO BOTTOM OF CLOSER	5-1/8" [130.2]	
MIN. TO BOTTOM OF COVER	5-7/8" [149.2]	
Dim. D		
MIN. STOP DEPTH RECOMMENDED	1-1/4" [31.8]	

* MIN. RAIL DIMENSIONS BASED ON 5/8" [15.9] STOP HEIGHT AND 1/8" [3.2] TOP DOOR GAP.

** DOOR MAY SWING UP TO 5° BEYOND STOP/HO POINT INDICATED



PDQ Manufacturing
2230 Embassy Dr.
Lancaster, PA 17603
833-273-7832
833-2 PDQTEC
www.pdqlocks.com