

# PT105 INSTALLATION TEMPLATE

## NOTES:

1. USE TRANSFER CASE HOUSING AS DRILLING TEMPLATE.
2. ONLY STRANDED WIRES TO BE EMPLOYED.
3. SPRING CONDUIT FITS WIRE BUNDLES UP TO 5/16" THICK.
4. USE CARE WHEN INSERTING WIRES THROUGH THIS DEVICE.
5. RECTANGULAR CUT-OUT IS 11/16" DEEP (MIN.) FOR WOOD FRAME.
6. WIRES SHOULD BE LABELED.
7. SIZE AND NUMBER OF WIRES MUST COMPLY WITH THE NATIONAL ELECTRICAL CODE, NFPA, AND LOCAL ELECTRICAL CODES.
8. THIS DEVICE IS INTENDED FOR LOW VOLTAGE USE ONLY (30 VAC, 42.5 VDC, 10 WATTS MAX.)

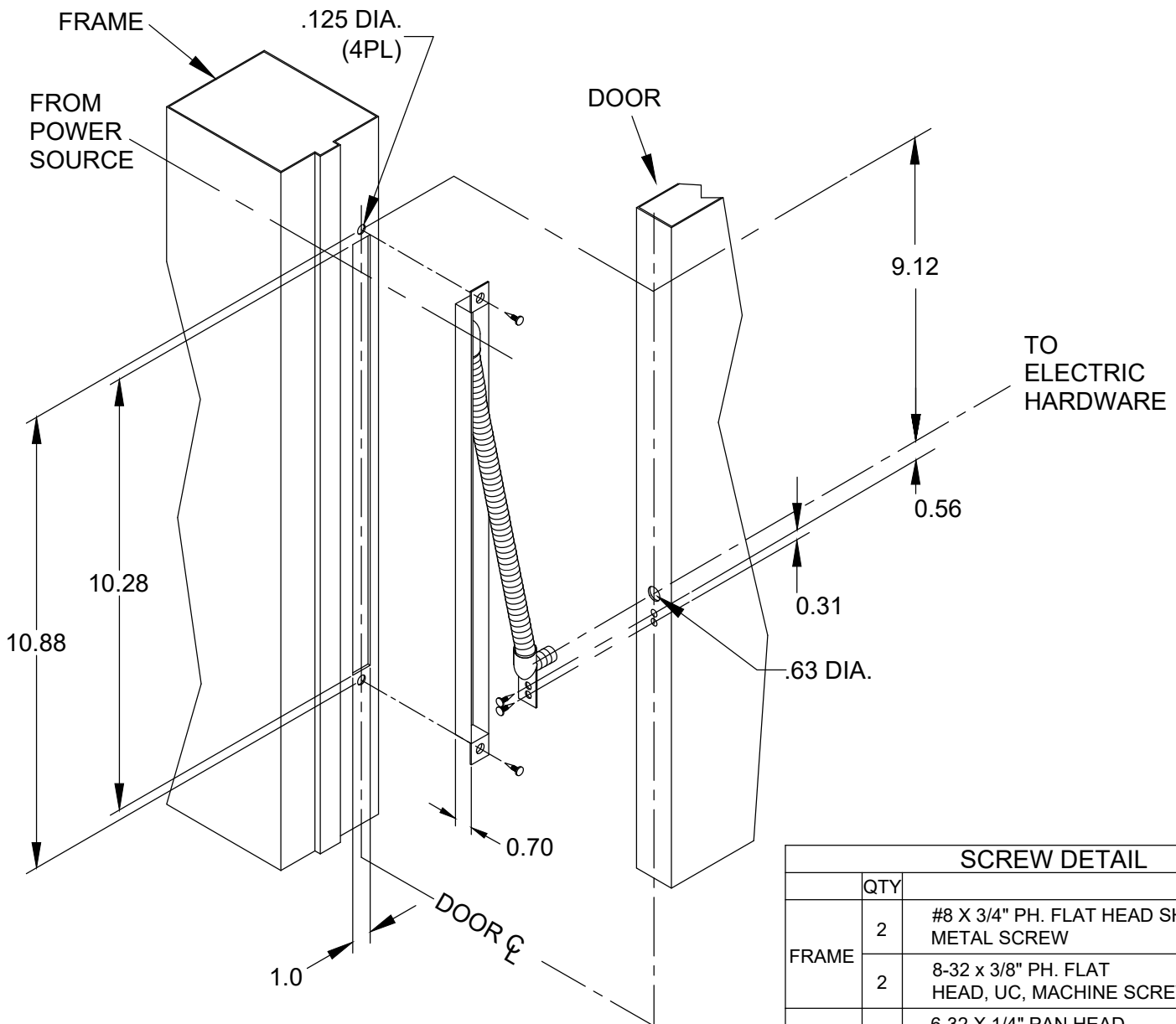

SCREW DETAIL		
	QTY	
FRAME	2	#8 X 3/4" PH. FLAT HEAD SHEET METAL SCREW
	2	8-32 X 3/8" PH. FLAT HEAD, UC, MACHINE SCREW
DOOR	2	6-32 X 1/4" PAN HEAD MACHINE SCREW