

Pemko Simultaneous Acting Sliding Door System

Easily create partitioned areas in your facility

The Pemko Simultaneous Acting Sliding Door System (SIM150) provides an elegant partitioning solution for hotels, conference centers, and restaurants. Using interior wood doors of your choice, the SIM150 system allows a portion of a large room to be closed off when not in use. To close, simply slide the lead door. The second and third doors then follow suit, telescoping out in a smooth linear fashion, closing off the area. When opened, the door panels stack and glide into storage pockets, maintaining a clean, minimalist look to the decor. Hotel breakfast areas or reception serving areas are examples of ideal applications for this system.

For new or retrofit applications, this easy-to-use system uses a unique single extrusion track and pre-assembled pulley system to significantly reduce installation time and eliminate alignment issues. Standard systems are offered as 2-door or 3-door handed systems as well as full 4-door or 6-door systems to accommodate most opening sizes.

Patent Pending

Features	Benefits
Easy to install with self-aligning components	Cuts traditional installation time by as much as 50%
Telescoping panels glide along the track and stack when not in use	Perfect for areas where space is limited
Compatible with wood doors of your choice	Allows an aesthetically pleasing partition that blends with the facility design
Meets requirements of ANSI/BHMA 156	Durable design to meet strict performance standards

Applications:

- Hotels
- Restaurants
- Conference Centers
- Office Buildings

© 2012-2017
Pemko Manufacturing Company

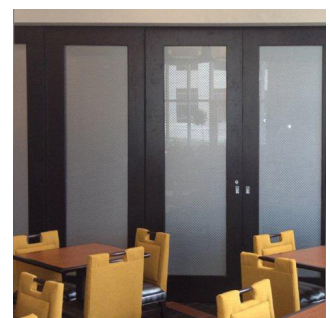

Hospitality Solutions

ASSA ABLOY offers a variety of product solutions for the hospitality market to save energy, improve acoustics and enhance aesthetics. These include adhesive gasketing, door bottoms, door shoes and the Privacy Door Latch (PDL).

The Pemko Simultaneous Acting Sliding Door System (SIM150) can be used with standard doors or as part of an overall partition door solution from ASSA ABLOY Group companies including ASSA ABLOY Wood Doors.

DOOR SPECIFICATIONS:

- For use with interior wood doors
- 25" to 48" wide per door panel
- 1³/₄" thick
- Up to 176 lbs. per door panel
- Can include lites/tinted glass

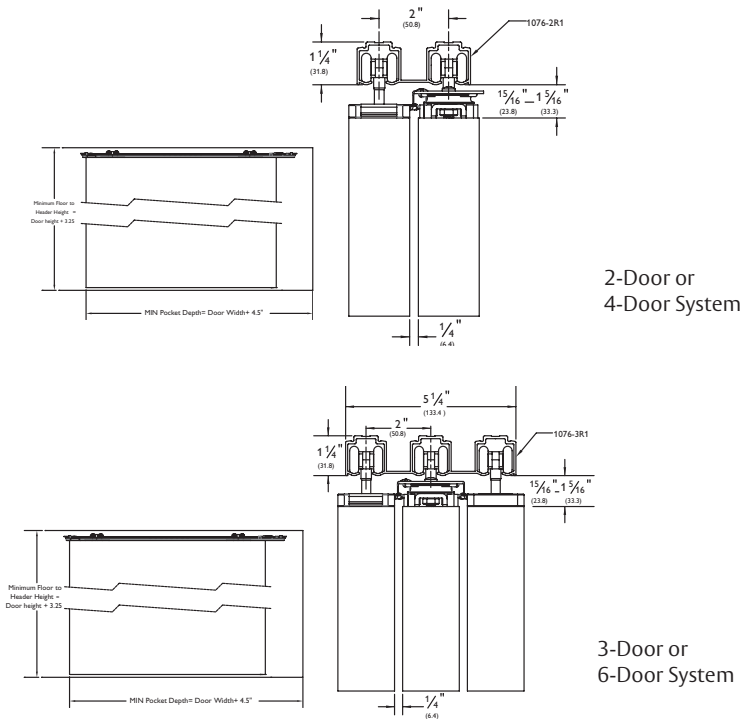

Technical Specifications:

The SIM150 System is available as single pocket 2-door and 3-door handed systems as well as double pocket 4-door and 6-door systems. The pre-assembled Pulley System is shipped fully assembled, ready to install.

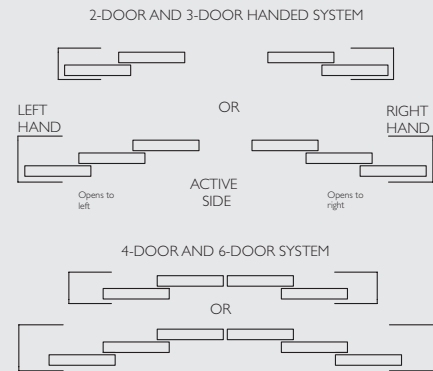

System Includes:

- Pre-Assembled Pulley System
- Single Extrusion Aluminum Track
- In-Track Stops and Hangers
- Door Bottom Guides
- Floor Stops, Back Stop and End Plates
- Installation Fasteners

Options:

- Track is available in Clear or Dark Bronze finish
- Snap-on Fascia available

Optional Hardware Kits:

- Lock Kit- includes lock, with edge pull, and cup pull
- Bolt Kit- includes surface bolt, dust-proof strike, cup pull and edge pull

Rough Opening Specifications:

- Recommended finished floor to header height is door height + 3.5"
- Minimum pocket depth is door width plus 4.5"
- Minimum 2-door pocket width is 4.25" plus width of any surface mounted hardware.
- Minimum 3-door pocket width is 6.25" plus width of any surface mounted hardware.

Standards:

- Meets performance requirements of ANSI/BHMA 156.14 (Grade 1) for sliding doors by exceeding 100,000 cycles in operation

Patent Pending

ASSA ABLOY

5535 Distribution Drive

Memphis, TN 38141

websales@pemko.com • www.pemko.com

MEMPHIS, TN USA

P: 800 824-3018

F: 800 243-3656

VENTURA, CA USA

P: 800 283-9988

F: 800 283-4050

VANCOUVER, BC CA

P: 877 535-7888

F: 877 535-7444

TORONTO, ON CA

P: 877 535-7888

F: 877 535-7444