

# PACER GLASS

GLASS WEIGHT	
3/8" glass	5.05 lbs./sq. ft.
1/2" glass	6.4 lbs./sq. ft.

See capacity section on page 9 for min./max. heights and weights.

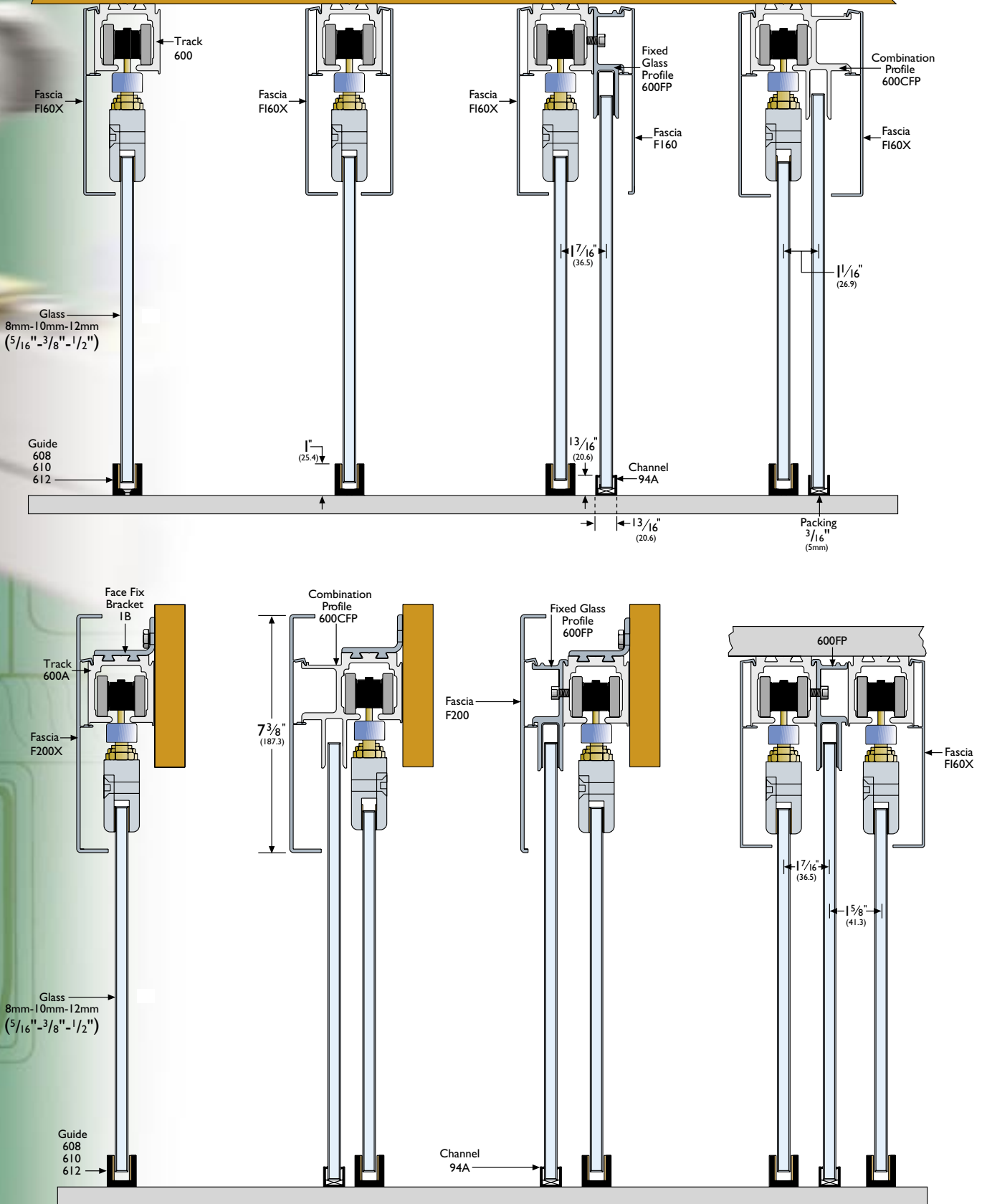

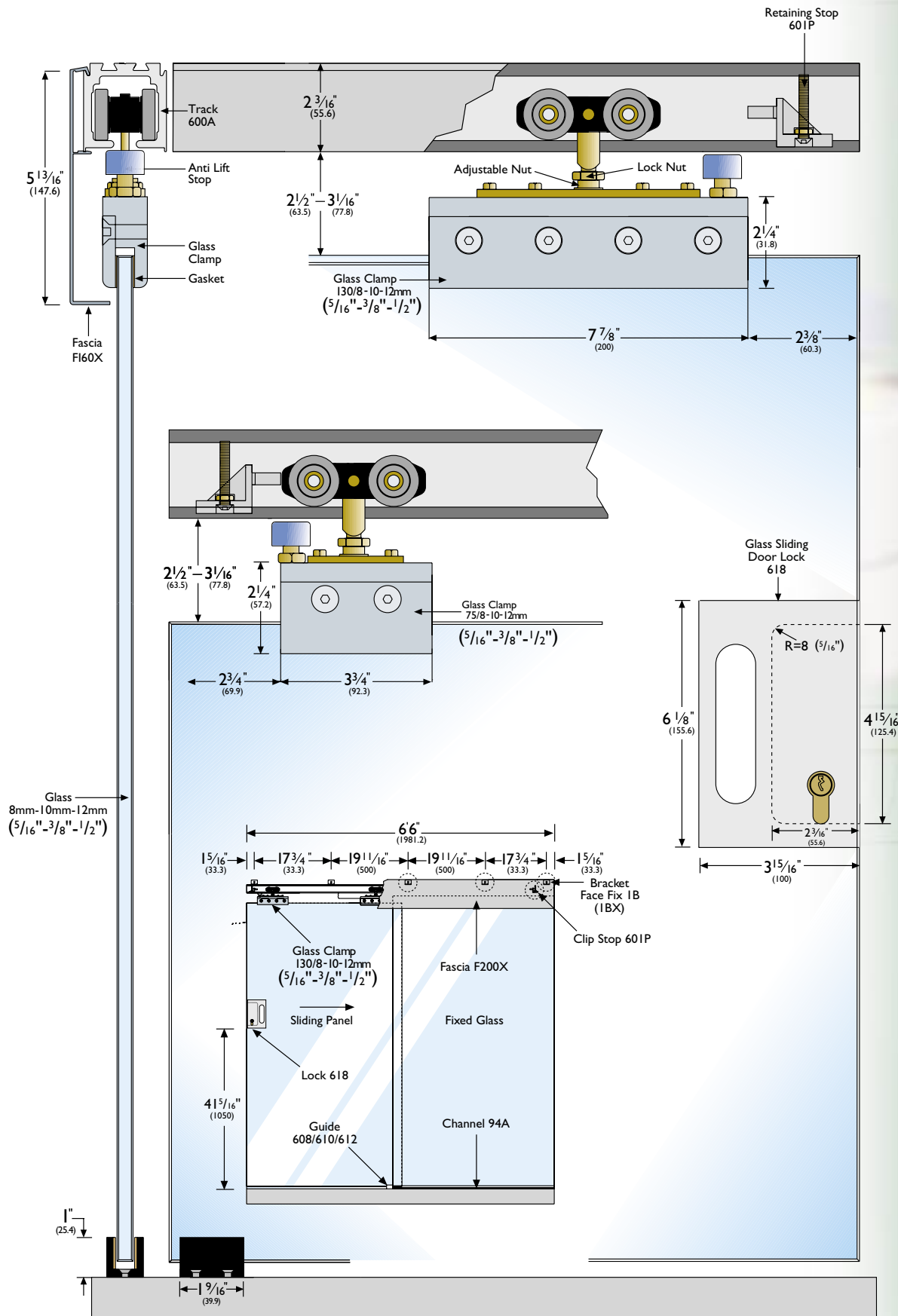
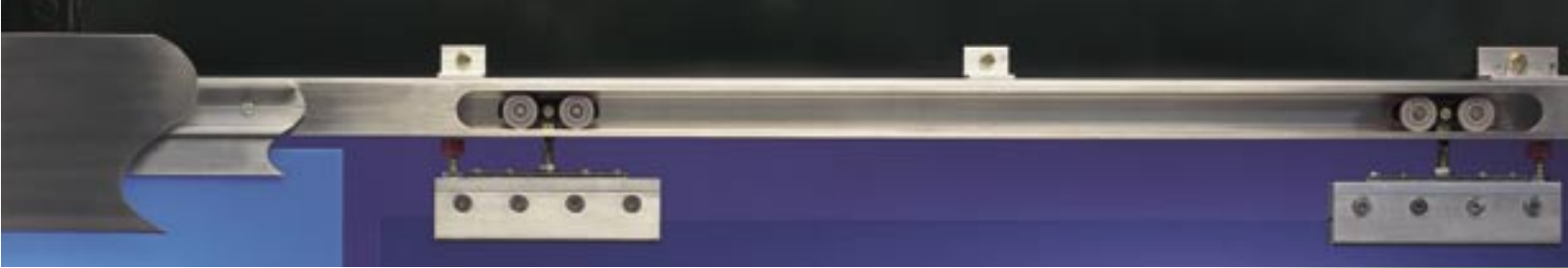



# FLEXIROL STRAIGHT SLIDING FOR TOP-HUNG WOOD, METAL OR GLASS DOORS

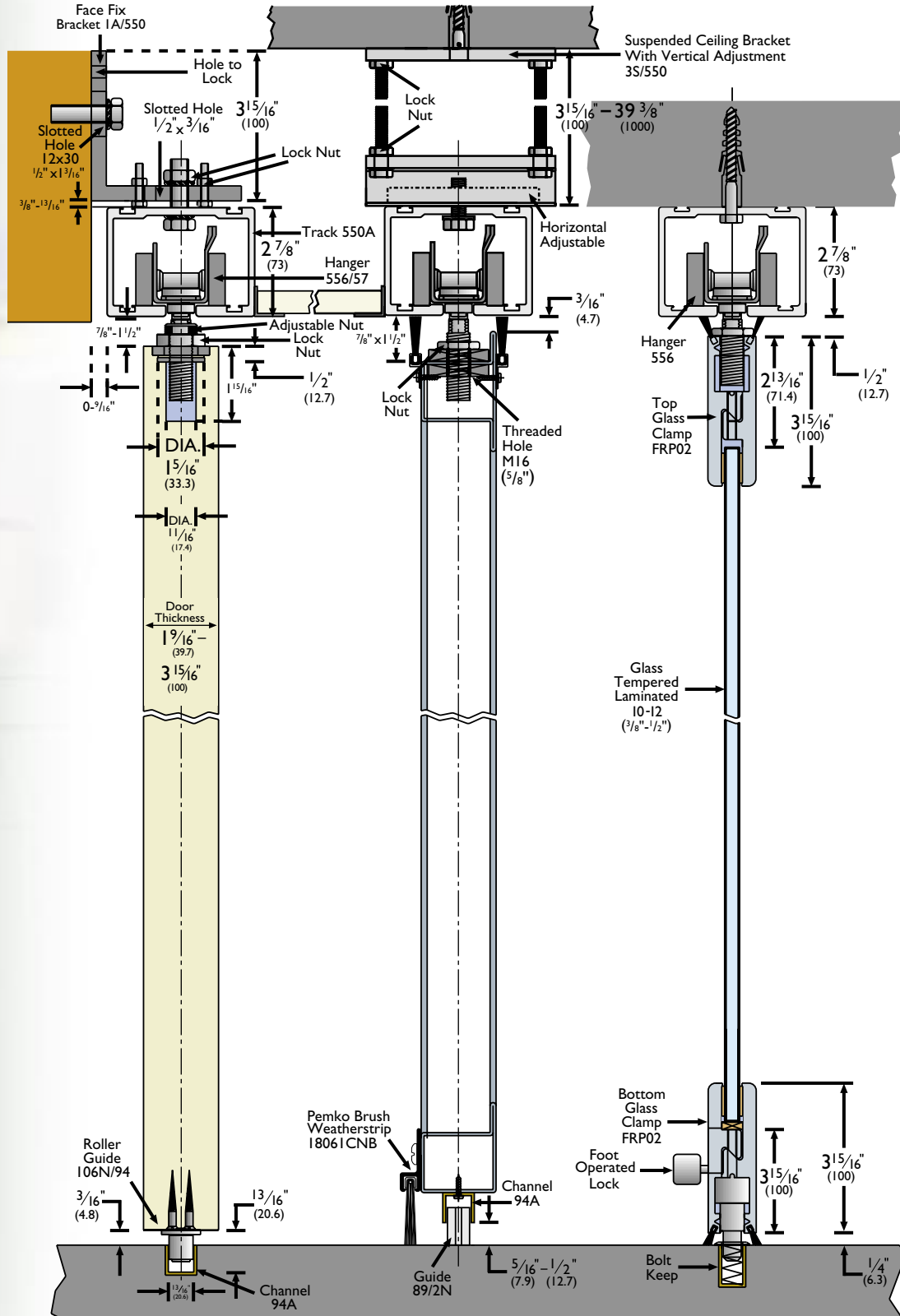

## CAPACITY

**Max. door weight:** 1100 lbs. (556 hanger) (500kg)

**Max. door height:** 19'8" (6000mm) - wood or metal framed  
 8'6" (2600mm) - 3/8" (10mm) tempered glass  
 13'2" (4000mm) - 1/2" (12mm) tempered glass  
 7'6" (2300mm) - 7/16" (10.76mm) laminated glass  
 8'2" (2500mm) - 1/2" (12.76mm) laminated glass

**Max. door width:** 19'8" (6000mm) - wood or metal framed  
 4'3" (1300mm) - 3/8" (10mm) tempered glass  
 4'11" (1500mm) - 1/2" (12mm) tempered glass  
 3' (900mm) - 7/16" (10.76mm) laminated glass  
 4' (1200mm) - 1/2" (12.76mm) laminated glass

**Door thickness:** 1 9/16" (40mm) - 3 15/16" (100mm) - wood or metal framed 3/8" (10mm) or 1/2" (12mm) - tempered glass

## APPLICATIONS

Henderson straight sliding Flexirol is ideally suited to hotels, conference centers, shop-fronts, showrooms or any site that requires high performance and attractive finish.

## DOOR TYPES

Wood doors, metal doors of either angle frame or box section and aluminum extrusion. Tempered glass panels of either 3/8" (10mm) or 1/2" (12mm) thickness and laminated glass panels of either 7/16" (10.76mm) or 1/2" (12.76mm) thickness.

**Note:** when using glass clamps in combination with protective coatings for glass surfaces such as Clear Shield, ensure that the glass surface to be clamped is not treated with the Clear Shield coating.

## TECHNICAL INFORMATION

<b>Track:</b>		550A
<b>Brackets:</b>	Face fix	1A/550
	Soffit fix	3S/550
<b>Hangers:</b>	Metal doors	556
	Wood doors	556/57 - concealed fixing
	Wood doors	556/52 - angle plate fixing
<b>Glass Profiles:</b>	Glass profile	FRP02
<b>Guides:</b>	Wood and metal doors	89/2N
	Wood doors	106N/94
	Metal doors	104N/94
	Metal doors, extended version	104NX/94
<b>Guide Channel:</b>	Brass	94
	Aluminum	94A
<b>Accessories:</b>	Flush pull	400
	Flush bolt	333/454
	Narrow flush bolt and keep	F3715 and F3734
	Trackstop	HH3/301
	Sliding door lock for glass panels	618 (3/8" (10mm) and 1/2" (12mm) glass only - see page 9)

## GLASS WEIGHT

3/8" glass	5.05 lbs./sq. ft.
1/2" glass	6.4 lbs./sq. ft.

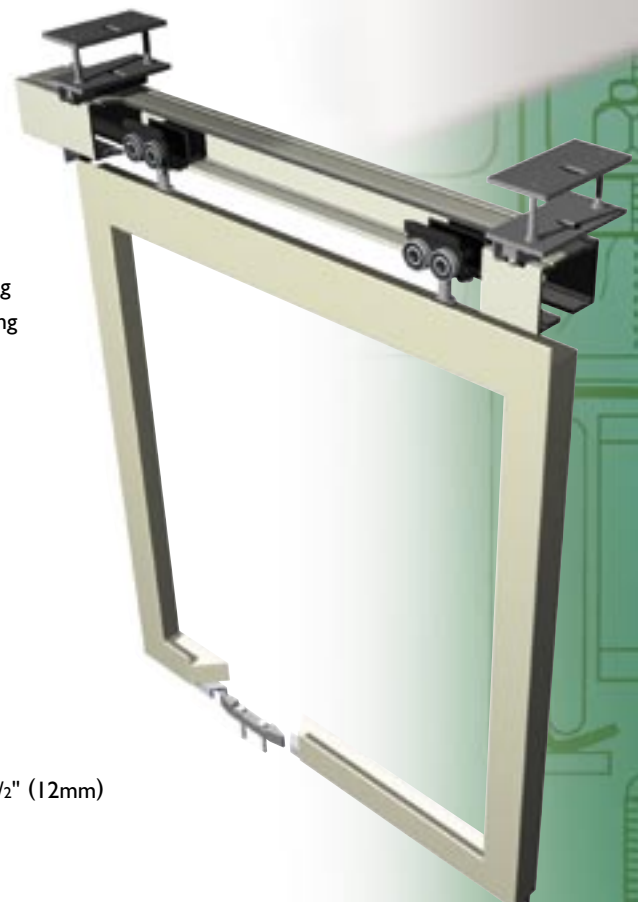
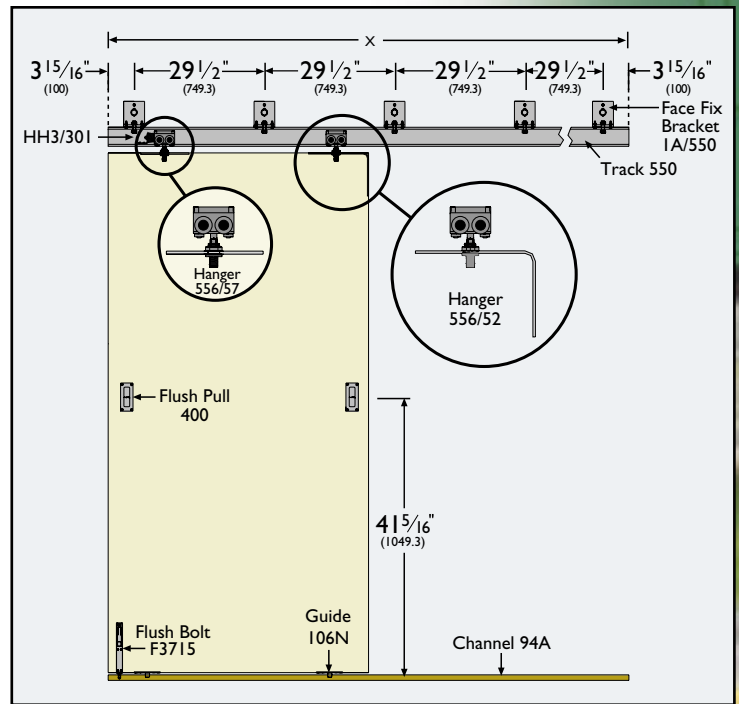

# HUSKY SLIDING 200

Reliable and highly versatile hardware using precision-made components for trouble-free operation.

FOR SLIDING WOOD OR METAL DOORS TO 200 lbs.

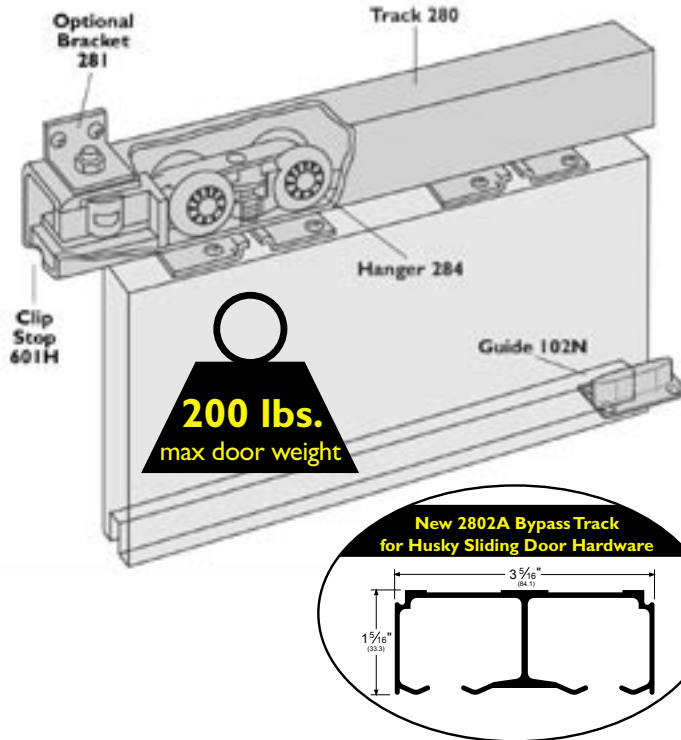

### KITS (complete, ready to install) include:

- 1 ea **280 or 280A** pre-drilled track, in steel or aluminum, 6 or 8 foot lengths
- 2 ea **284** nylon bodied, needle bearing, acetal wheel hangers
- 1 ea **102N** nylon guide
- 2 ea **601H** clip stops

(Kit components can be ordered individually)

### Order KITS based on material and length of track:

Kit No.	Material	Max Leaf Size
<b>H200/6</b>	steel track/6 ft.	96" x 36" x 2"
<b>H200/8</b>	steel track/8 ft.	96" x 48" x 2"
<b>H200A/6</b>	aluminum track/6 ft.	96" x 36" x 2"
<b>H200A/8</b>	aluminum track/8 ft.	96" x 48" x 2"

### HARDWARE PACK (no. "H200PACK") = KIT w/o track:

- 2 ea **284** nylon bodied, needle bearing, acetal wheel hangers
- 1 ea **102N** nylon guide
- 2 ea **601H** clip stops

### BYPASS PACK ALSO AVAILABLE (no. "HBP200PACK")

### OPTIONAL EXTRAS include:

- 281** 281 brackets - 5 each
- 287** track stop (bumper type)
- 285** hanger for metal doors
- 106R/94** roller guide (use w/94A)
- 94A** aluminum floor channel

**F134**

**F138**

**863**

**400**

**414**

**333**

- aluminum fascia - 1-3/4" thick doors
- aluminum fascia - 1-3/8" thick doors
- iron bow handle (5-1/4" x 1-3/4")
- aluminum flush pull (4-1/4" x 1-7/8", 5/8" mortise)
- aluminum flush pull (5-1/4" x 2-1/2", 3/4" mortise)
- aluminum flush bolt (6" x 1-3/8")

## FACE FIXED

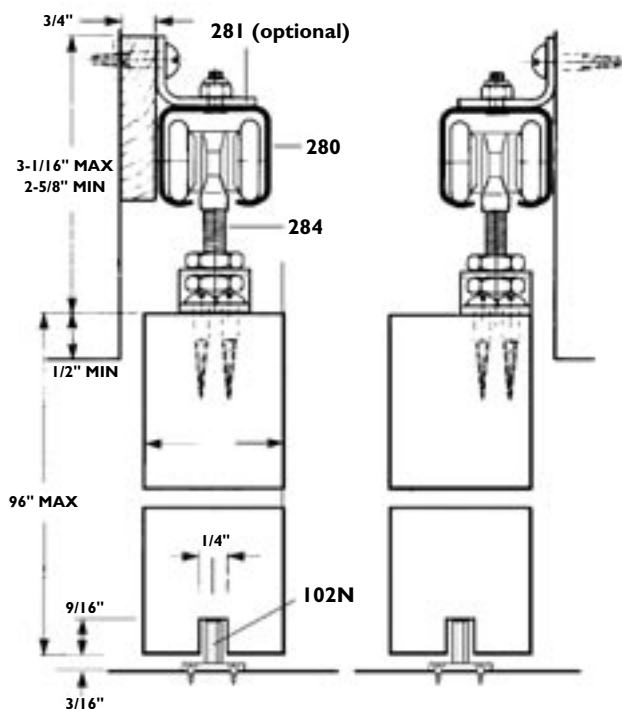

## SOFFIT FIXED

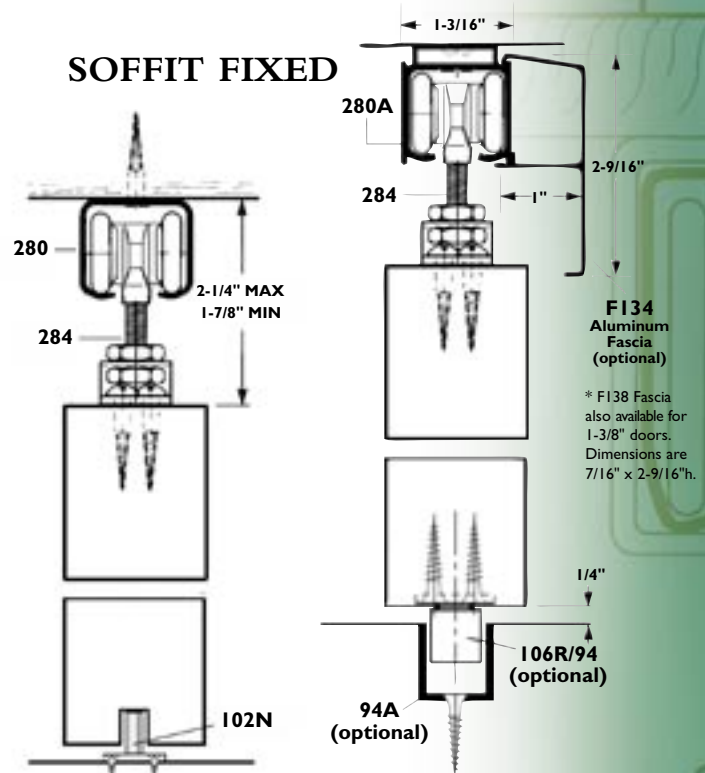

**F134**  
Aluminum  
Fascia  
(optional)

\* F138 Fascia  
also available for  
1-3/8" doors.  
Dimensions are  
7/16" x 2-9/16".



# HUSKY GLASS

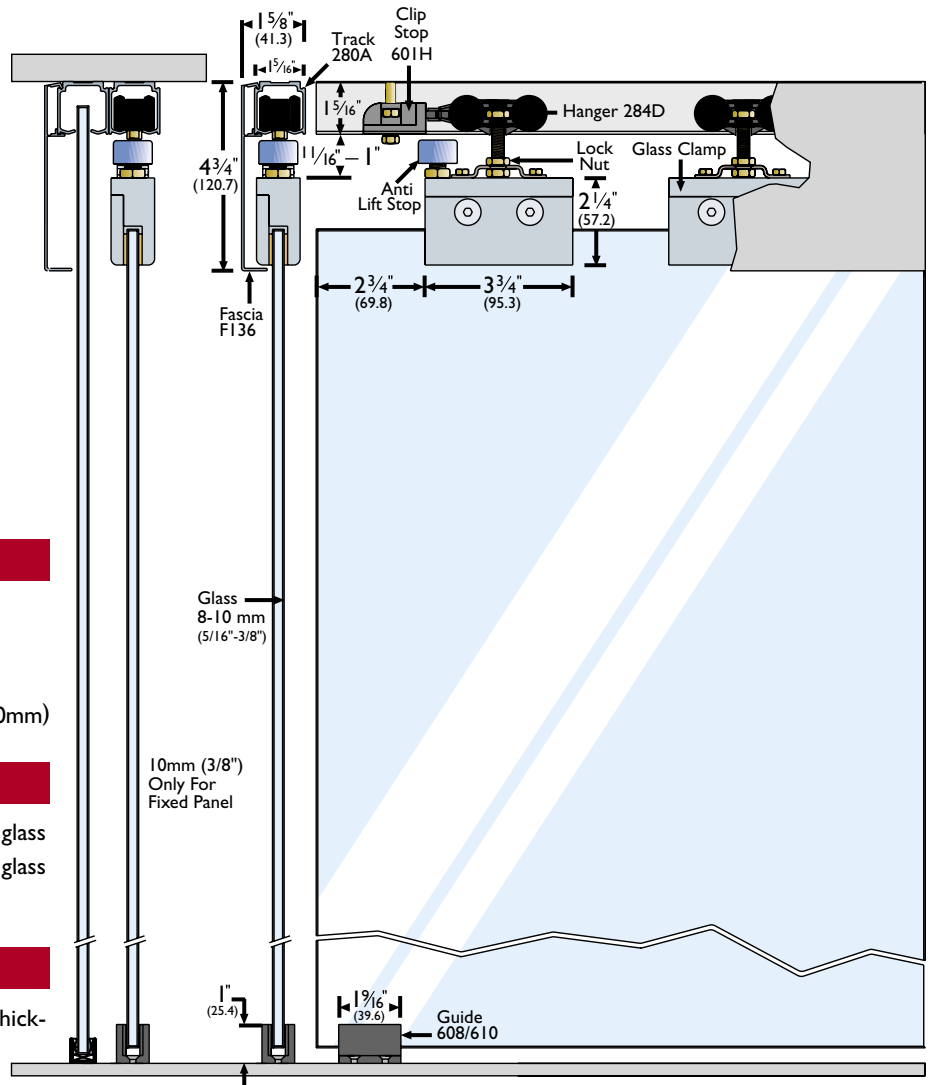

## CAPACITY

- Max. door weight:** 165 lbs. (75kg)
- Max. door height:** 7'10" (2400mm)
- Max. door width:** 4'1" (1250mm)
- Glass thickness:** 5/16" (8mm) and 3/8" (10mm)

## APPLICATIONS

Husky offers a solution to lightweight glass applications such as office doors and small glass partitions.

## DOOR TYPES

Glass panels of 5/16" (8mm) or 3/8" (10mm) thickness in tempered or laminated glass.

Glass Clamp kits contain: 2 hangers, 2 clamps, 2 end track stops and 2 floor mounted guides.

**Note:** When using glass clamps in combination with protective coatings for glass surfaces such as Clear Shield, ensure that the glass surface to be clamped is not treated with the Clear Shield coating.

## TECHNICAL INFORMATION

- Track:** 280A (extruded aluminum)  
Available in 6', 8', and 12' lengths
- Brackets:** Face fix 281  
5-pack 2815
- Fascias:** Soffit fixed track F136
- Glass Clamp Kits:** For glass panels from  
5/16" (8mm) up to 8/75/I Kit - 8mm  
3/8" (10mm) 10/75/I Kit - 10mm

- Guides:** 5/16" (8mm) glass panels 608 - glass guide  
3/8" (10mm) glass panels 610 - glass guide

- Accessories:** 601H retaining stop mounted within the track



## GLASS WEIGHT

5/16" glass	3.95 lbs./sq. ft.
3/8" glass	5.05 lbs./sq. ft.

# PACER STRAIGHT SLIDING FOR TOP-HUNG WOOD AND METAL DOORS

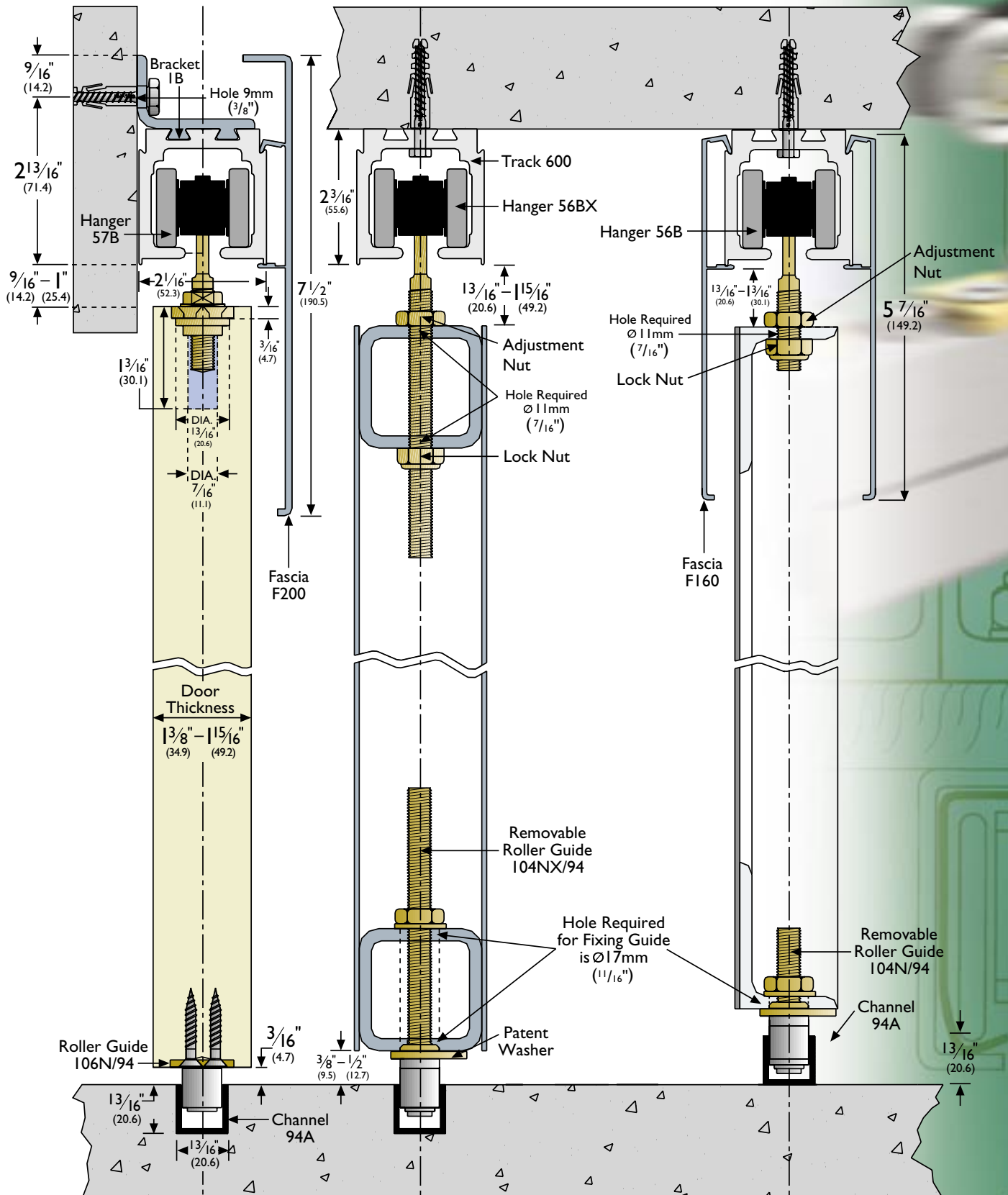

## CAPACITY

**Max. door weight:** 440 lbs. (200kg)

**Max. door height:** 9'10" (3000mm)

**Door thickness:** 1 3/8"-1 5/16" (35mm-50mm)

## APPLICATIONS

Combining performance and style with versatility, Pacer straight sliding in wood, glass, aluminum or metal is ideally suited for shop-fronts, offices and other stylish interiors.

## DOOR TYPES

Wood doors for interior applications can be either solid or glazed. Metal doors can be of angle or box section. Aluminum is dependent on extrusion profile.

## TECHNICAL INFORMATION

**Track:** Aluminum  
Available in 6', 8', 10', and 16' lengths

**Brackets:** Face fix  
Joining bracket

**Fascias:** Soffit fixed track  
Face fixed track

Fascia comes in a satin anodized aluminum finish in lengths of 6', 8' and 10'

**Hangers:** Wood doors  
Wood doors  
Aluminum/Metal doors  
Metal doors  
Metal doors

**Guides:** Wood/Aluminum/Metal doors  
Wood/Aluminum doors  
Metal doors  
Metal doors

**Guide Channel:** Brass  
Aluminum

94 channel available in 4'11"  
(1.5 meter) and 9'10" (3 meter) lengths.  
94A channel available in 6', 8', and  
12' lengths.

**Accessories:** Retaining stop mounted within the track 601P

600A

IB  
IBX

F160 with standard return  
F200 with standard return

57B - concealed fixing  
52B - angle plate fixing  
57B - concealed fixing  
56B - angle frame  
56BX - box frame

89/2N - floor mounted guide  
106N/94 - concealed fixing  
104N/94 - angle frame  
104NX/94 - box frame

94

94A

