

# INSTALLATION INSTRUCTIONS for RDL Lever Lock with Simpli™ Roseless Trim

**SARGENT®**

**ASSA ABLOY**

FOR INSTALLATION ASSISTANCE CALL SARGENT AT 1-800-727-5477 / [www.sargentlock.com](http://www.sargentlock.com)  
Patent pending and/or patent [www.assaabloydss.com/patents](http://www.assaabloydss.com/patents)

## Installing an RDL Lock

### STEP 1

- Assemble Spindle to Outside Mounting Plate Assembly.
- Position Privacy Plate onto door with Privacy Button holes aligned. (65 Function only)
- Insert Outside Mounting Plate Assembly into door.

Tools Required:
Phillips Screwdriver
T20 Torx Wrench
Lever Base Tool (Provided)

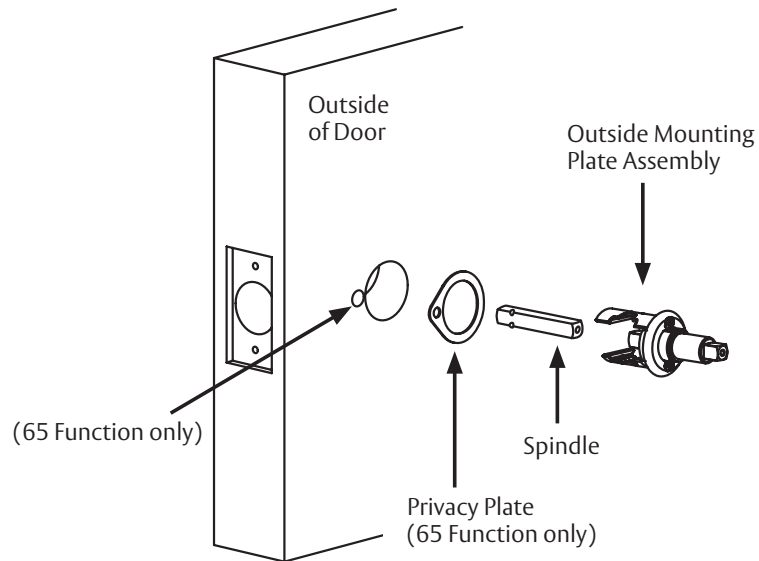

### STEP 2

- Insert Latch Assembly.
- Position the threaded hole on the Latch Assembly towards the inside of the door. (65 function only)

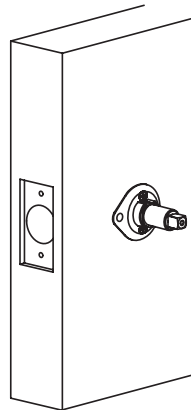
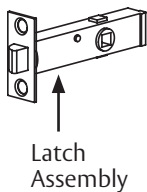

### STEP 3

- Assemble Privacy Button to Latch Assembly (65 function only).
- Position Privacy Plate on door with Privacy Button holes aligned.
  - Insert Privacy Button through plate & door holes, thread into Latch Assembly.

**Note:** Loosening the pre assembled #6-32 screws on the outside mounting plate may improve alignment for thicker doors.

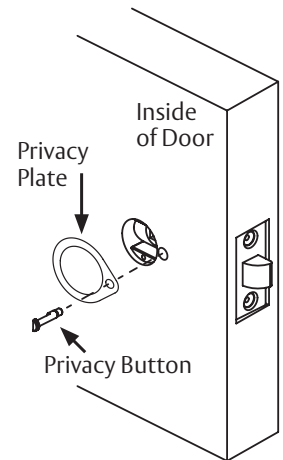

### STEP 4

- Assemble Spindle to Inside Mounting Plate Assembly.
- Position and secure Inside Mounting Plate Assembly with (2) #6-32 screws provided (not shown).

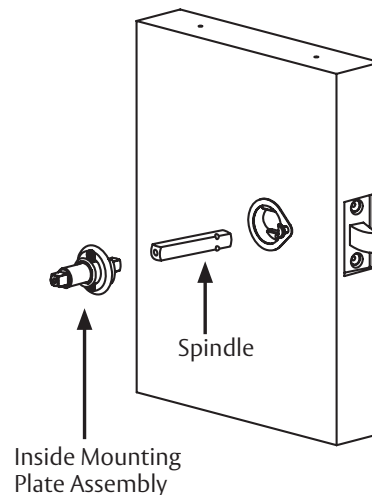
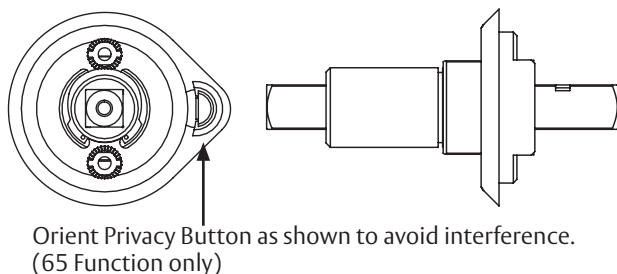

## STEP 5

Rotate and verify the set screw hole in both Mounting Plate Assemblies face the hinge and push both Spindles into the Latch Assembly Hubs.

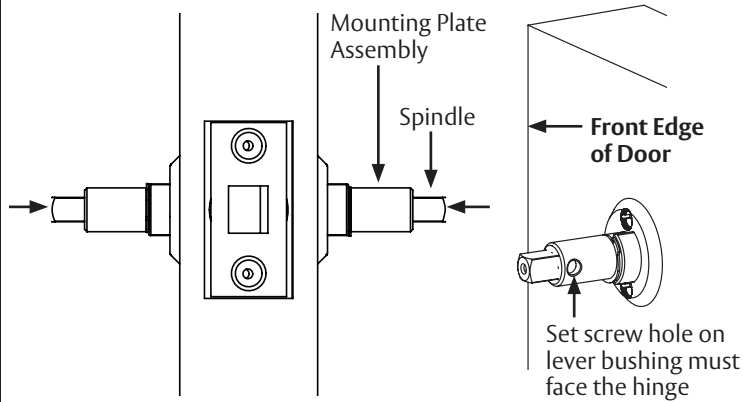

## STEP 6

Position the Outside Front onto the Latch Assembly and secure with the provided screws.

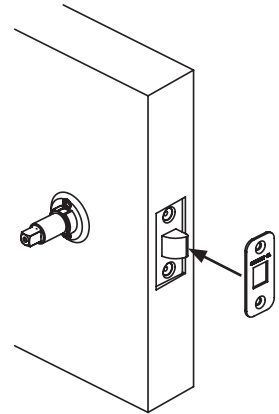

## STEP 7

Assemble the inside and outside Collars by threading to the Mounting Plate with provided tool.

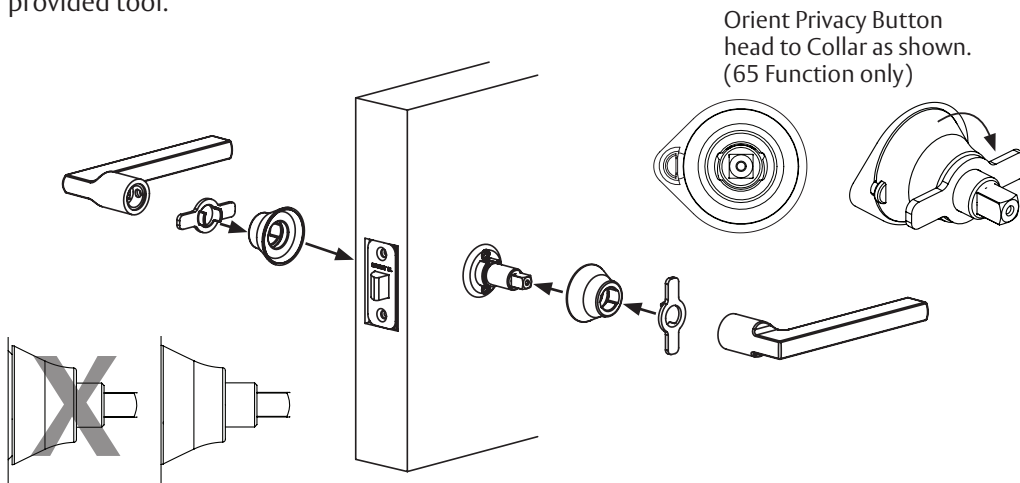

**Note:** Collars must lie flush against the door

## STEP 8

Assemble the inside and outside Levers with provided set screw (not shown).

- Test assembly
- Install Strike

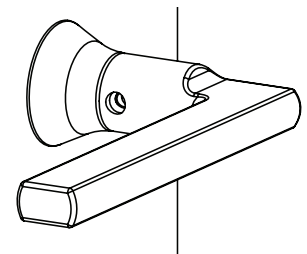

## Dummy Trim Assembly Shown

Use assembly steps 1, 4, 5, 7 & 8 for dummy trim installation.

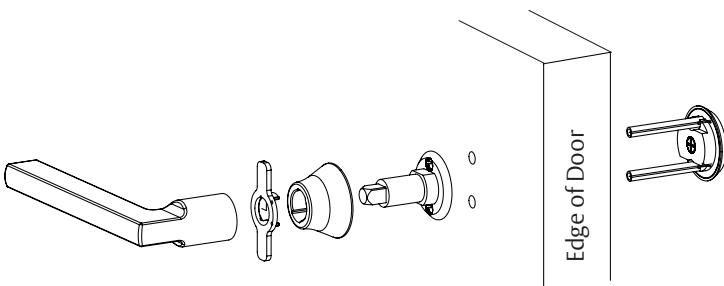

## Template for RDLU93 & RDLU94

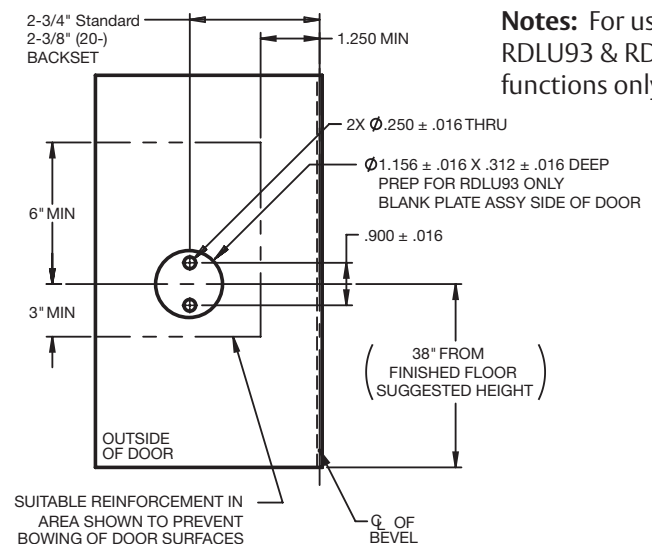

**SARGENT**

**ASSA ABLOY**

ASSA ABLOY, the global leader in door opening solutions

Copyright © 2018, Sargent Manufacturing Company, an ASSA ABLOY Group company. All rights reserved. Reproduction in whole or in part without the express written permission of Sargent Manufacturing Company is prohibited.

A8046:C