

1460/3460



STANDARD FEATURES

- **Model 1460** - Fail-secure
- **Model 3460** - Fail-safe
- Faceplate size 1 3/8" x 9"
- Stainless steel, corrosion-resistant faceplate, suitable for hollow metal, aluminum or wood frames
- Keeper depth - 5/8" maximum latch projection possible with 1/8" door/frame clearance - 3/4" Keeper opening starts at center line
- Fully tamper proof horizontal adjustment
- 1 1/2" jamb modification
- Reversible - non-handed (without deadbolt)
- Limited warranty - 36 months

OPTIONAL FEATURES

Cutout for deadbolt
(Specify 1460B-LH or 1460B-RH with required voltage)

SPECIFICATION

TAMPER STRENGTH	1700 LB (765 KG)	
VOLTAGE	1460-01	8-16 VAC/3-6 VDC
	1460-05	12 VAC/VDC
	1460-08	24 VAC/VDC
	3460-06	12 VDC
	3460-09	24 VDC
FINISH	US32D, US3 (plated) or US10B	

SPECIFICATION DETAILS

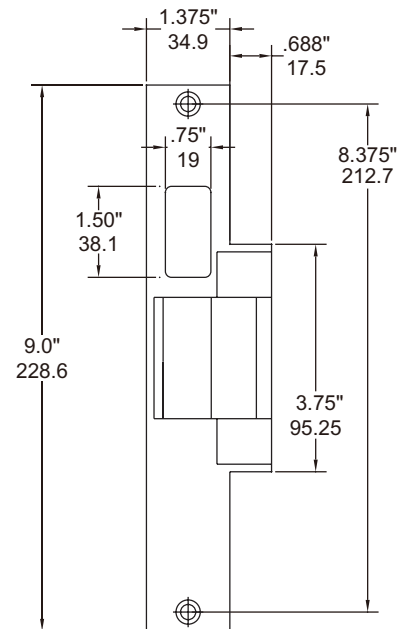
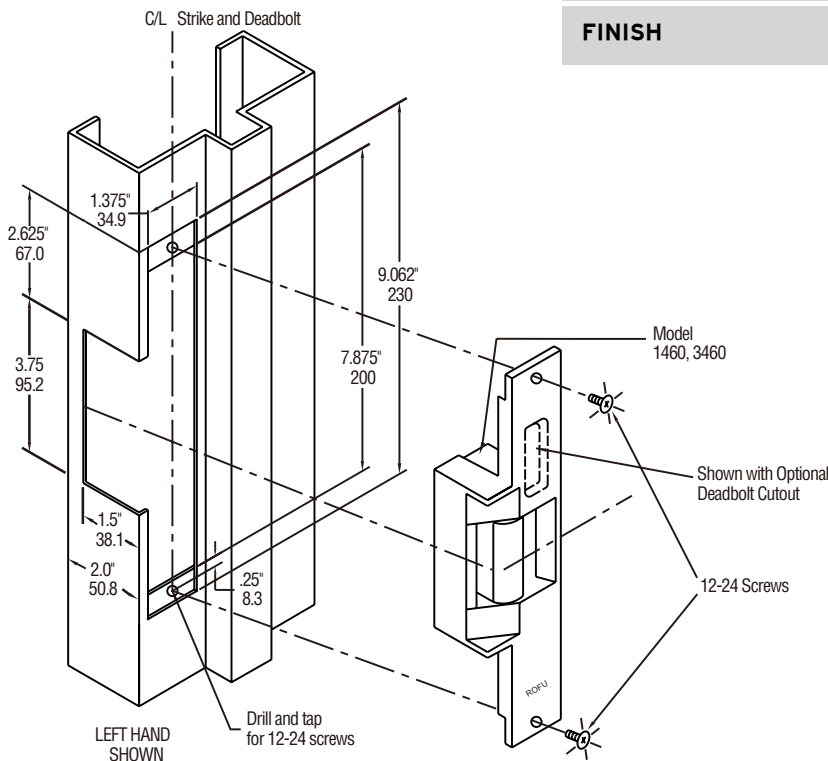

ELECTROMAGNETS

ELECTRIC STRIKES

EXIT DEVICES

MISC. ACCESS CONTROL