

### Model 1351

Max. Gate Size: 54" x 120"

Pull Side Mount ONLY

#### Tools Required

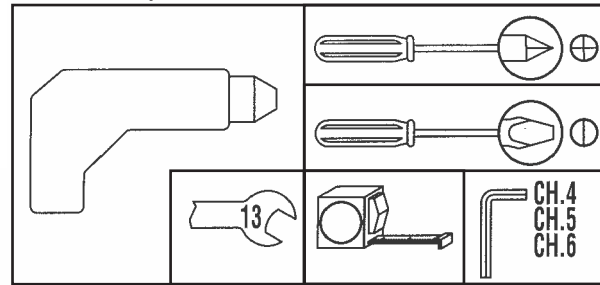

- 1 Locate and mark closer mounting plate.**  
 Using one aluminum slide track (B), insert it into the closer mounting plate (A). This insures the track will be in exact alignment to the closer body. Mark the hole locations on the post.  
**IMPORTANT:** Position (A) so the closer portion of the plate will be mounted to the pull side of the gate.

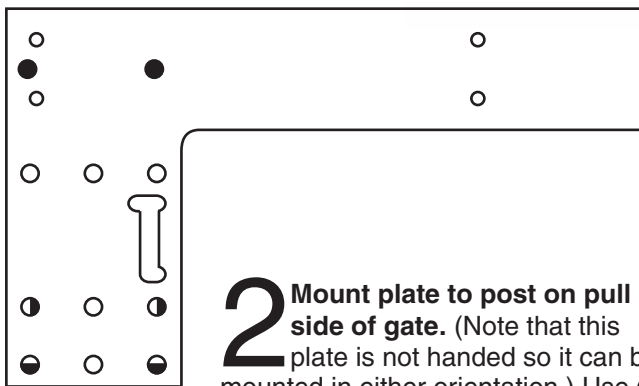
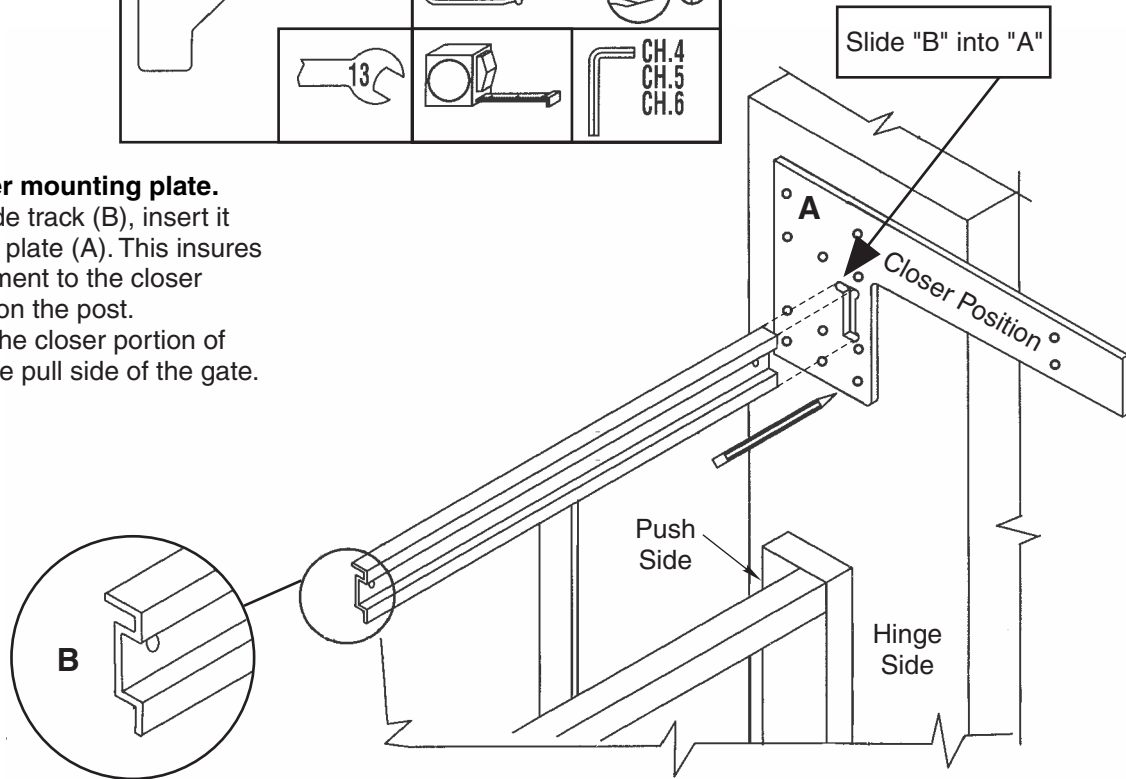

- 2 Mount plate to post on pull side of gate.** (Note that this plate is not handed so it can be mounted in either orientation.) Use ● and ○ holes for masonry post mounting. Use ○ and ● holes for tubular post mounting. Attach (A) with four hex screws. If the gate post is masonry, use the longer screws with the anchors included in the package. If tube post extends above gate, use masonry hole locations.

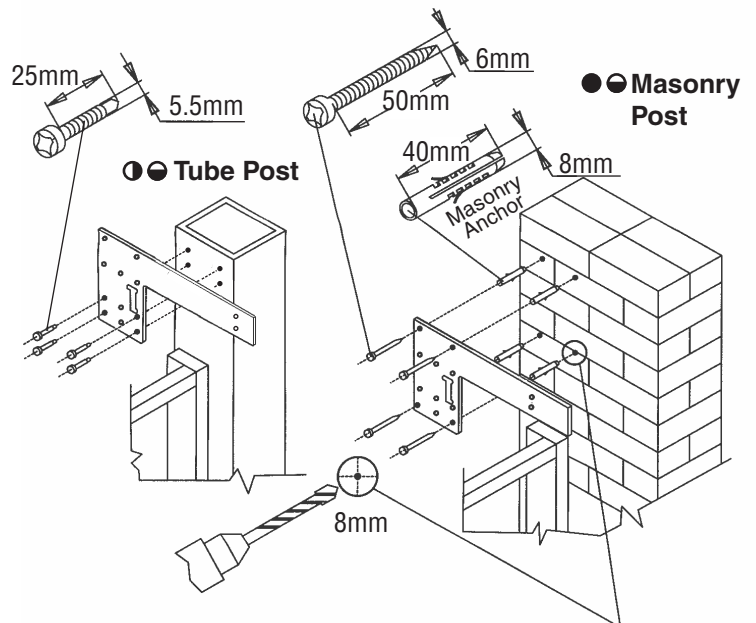

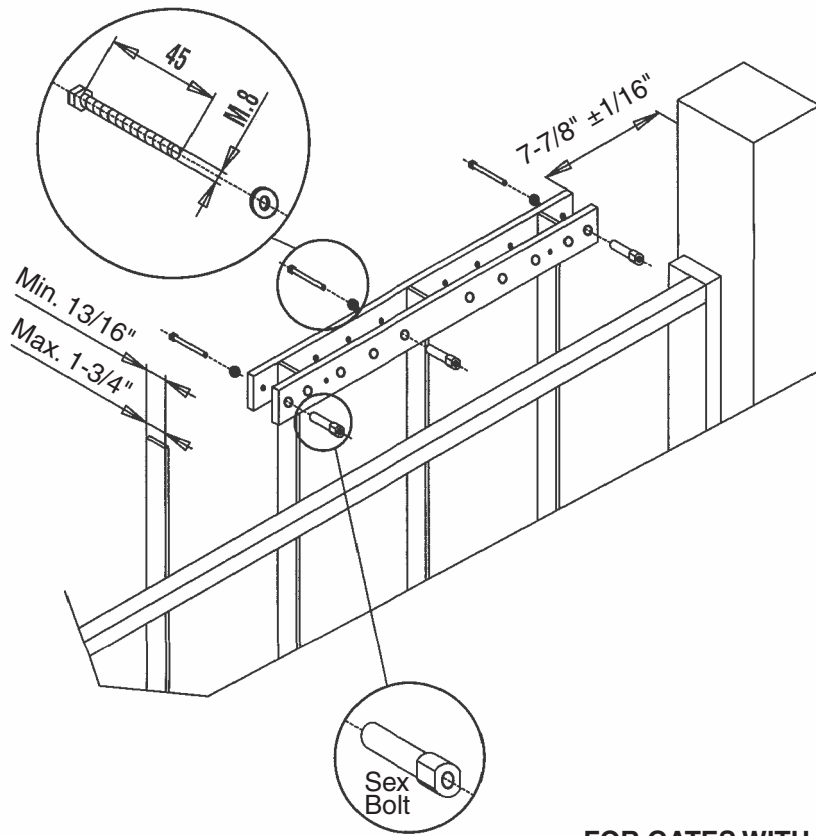

**3 FOR OPEN SPOKE GATE TOP**  
 Put the steel plates on either side of the spokes. This will sandwich the spokes between the two steel plates. Position the first screw of the plate so that from the face of the post to edge of the steel plate is approximately 7-7/8" (200mm ±10). Using the supplied sex bolts and the larger screws on the plates, attach as many mounting screws as possible to secure the two plates to the gate spokes.

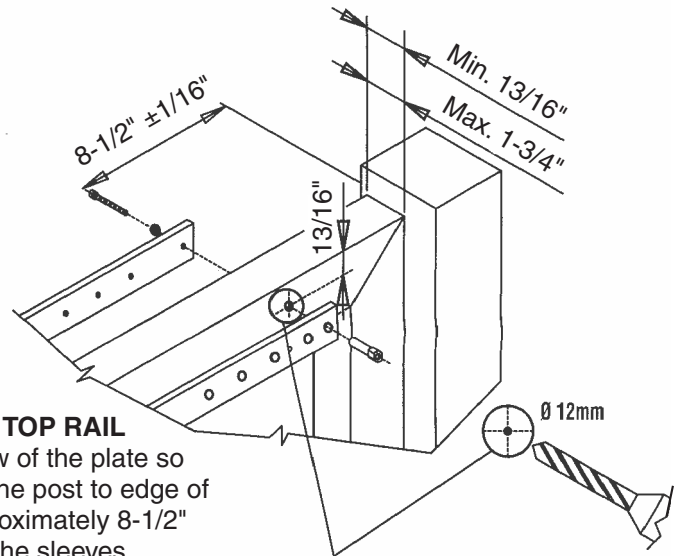

**FOR GATES WITH A TOP RAIL**  
 Position the first screw of the plate so that from the face of the post to edge of the steel plate is approximately 8-1/2" (215mm ±10). Using the sleeves provided, secure the two plates to the top rail of the gate.

**4** On pull side of the gate attach only one side of 2 slide tracks to steel plates with 1 of 2 screws provided.

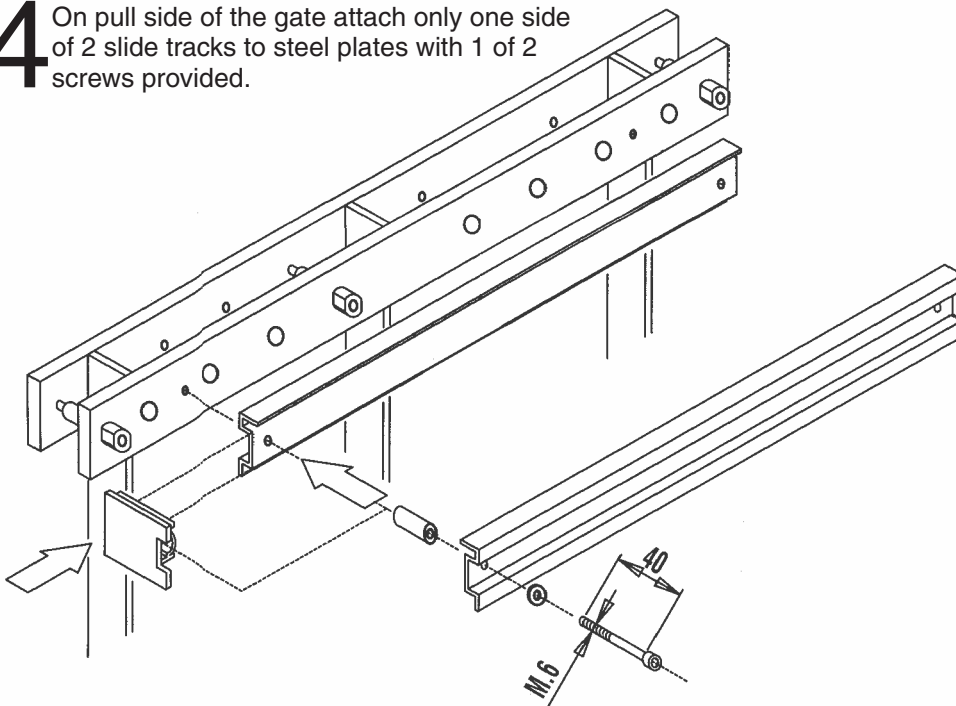

**5** Insert pin into guide.



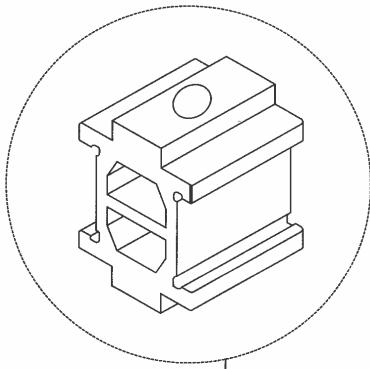

**6** Insert guide with pin into open end of the track assembly.

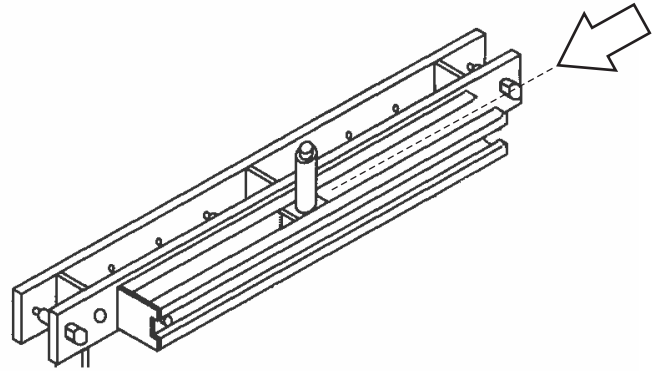

**DO NOT PAINT**

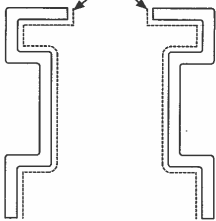

**7** Attach second track end cap to steel plates with screws provided. It may be necessary to gently pull apart the two tracks allowing room to insert the metal sleeve.

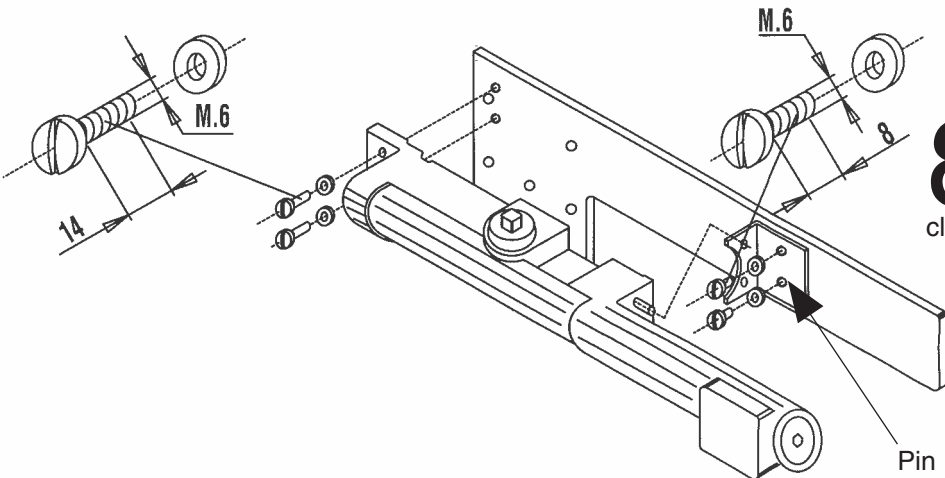
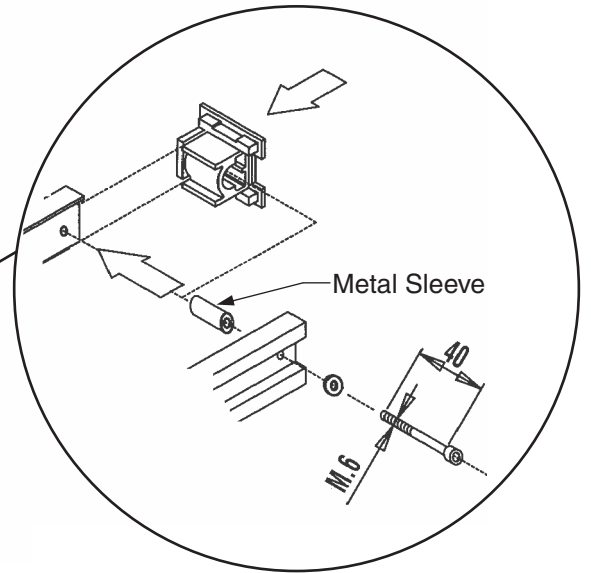
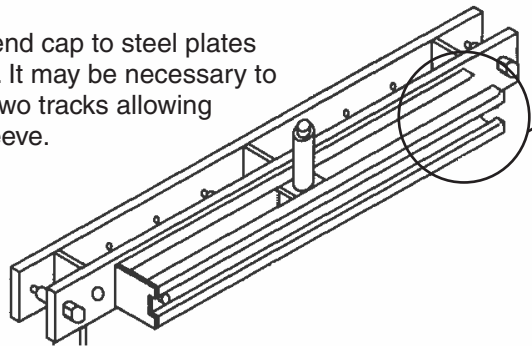

**8** Attach surface closer to closer mounting plate on the post. Attach pin retainer bracket to closer mounting plate and mount closer with pins and screws.

**9** Attach arm to closer spindle with screw and washer.

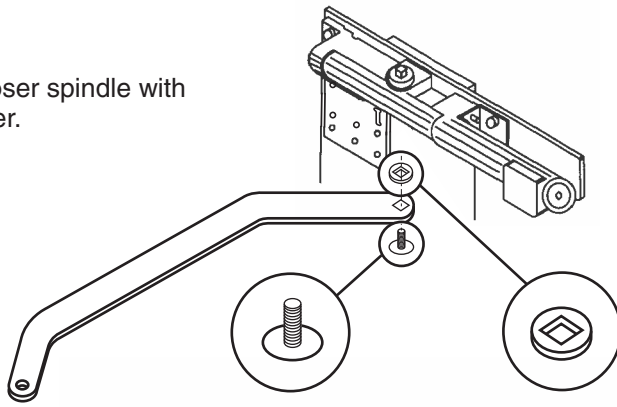

**10** Attach arm to the pin in the guide.

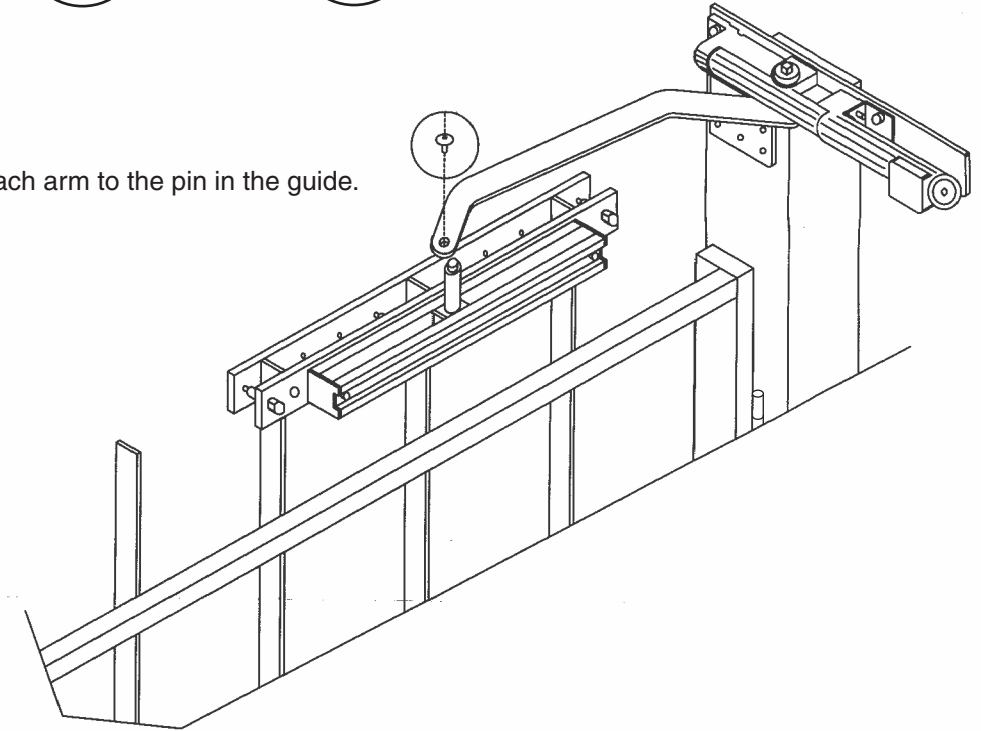

**11** Make closer adjustments:  
1- Closing Speed  
2- Latch Speed  
3- Closing Force  
4- Backcheck Control

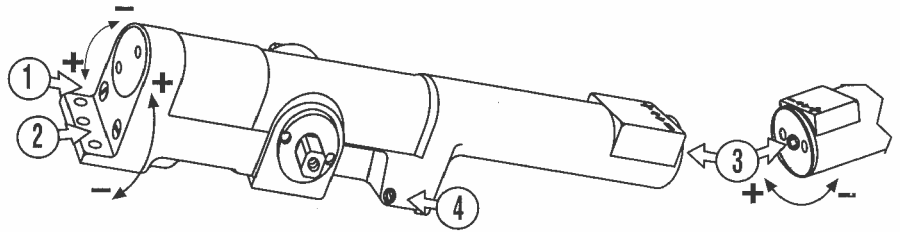

**12** Snap on closer cover and cap.

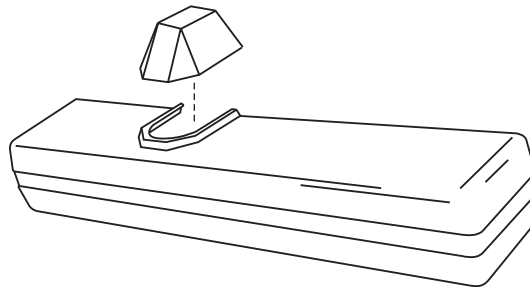

**RIXSON®**  
**ASSA ABLOY**

ASSA ABLOY is the global leader in door opening solutions, dedicated to satisfying end-user needs for security, safety and convenience.

Rixson® is a registered trademark of Yale Security Inc., an ASSA ABLOY Group company. Copyright© 2009, 2013, Yale Security Inc., an ASSA ABLOY Group company. All rights reserved. Reproduction in whole or in part without the express written permission of Yale Security Inc. is prohibited.