

## DOOR INSTALLATION

### Top Door Rail ("S"Type Side Loading Arm)

- Drill or drill and tap holes in top of door as shown.
- Make a 2-1/4" (57.2) x 1/2" (12.7) cutout in top of door as shown. (See Step 1.) Cutout must be on the inside face of the door.
- After installation of door, attach cover plate with self-tapping screws as provided.  
**NOTE:** Before attaching cover plate, make certain the three(3) 1/4-20 x 7/8" socket head clamp bar cap screws with 1/2" (12.7) lockwashers are tightened securely.
- Install arm (Step 2) using 1/4-20 x 3/4" flat head machine screw and 7/8" (22.2) washer. Install 1/2-13 x 3/4" arm stud and 1/4-20 x 1-1/8" dome head arm adjustment screw.
- Laterally adjust center of the arm spindle retainer 2-5/8" (66.7) from outside edge of door (not including weatherstripping). Center arm in the top rail by adjusting the two(2) 1/4-20 x 1" hex head centering bolts.
- NOTE:** After door is installed, the three(3) 1/4-20 x 7/8" socket head clamp screws with 1/2" (12.7) lockwashers must be tightened securely.

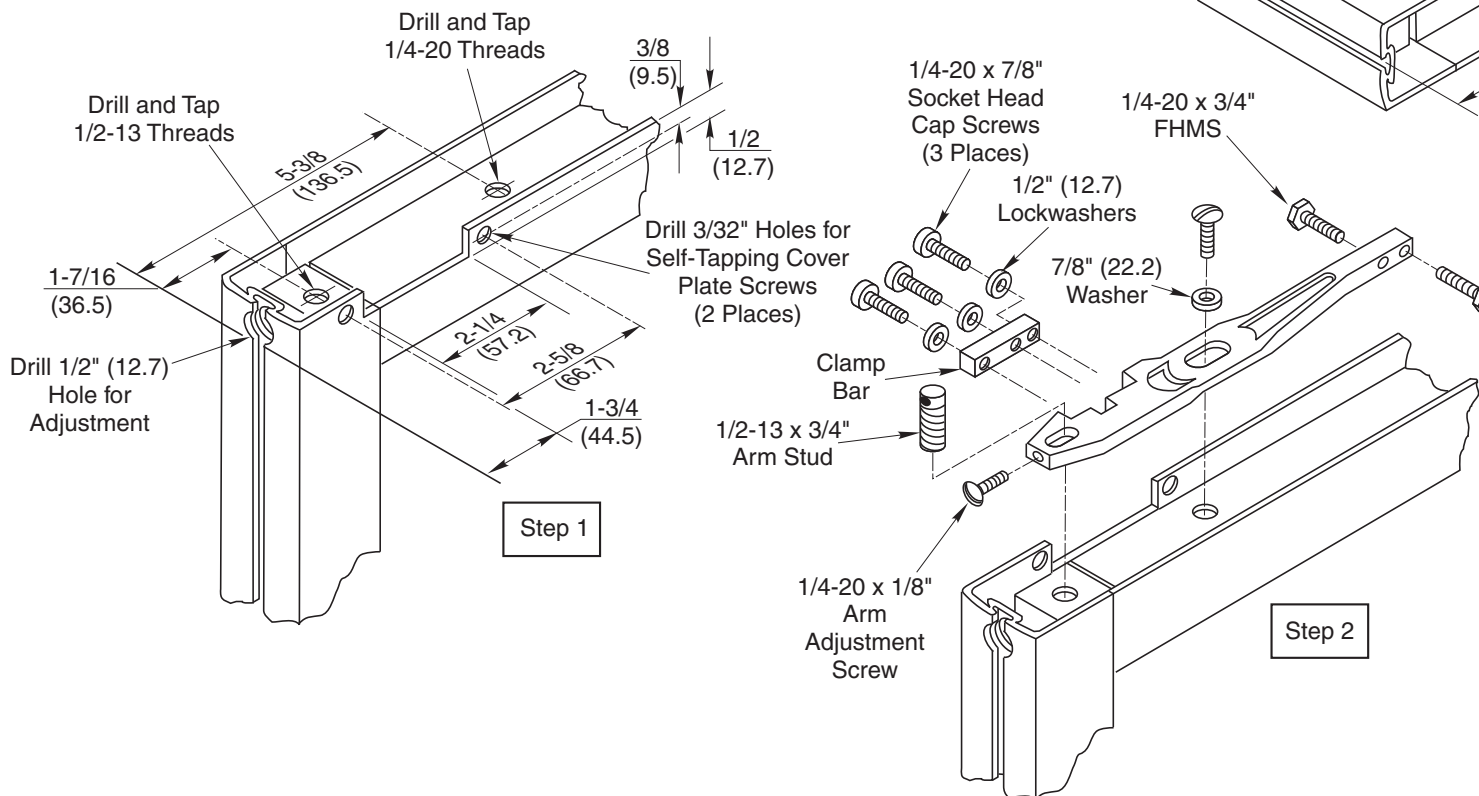

### Bottom Door Rail (Side Loading)

- Drill and tap 1/4-20 holes in bottom rail of door as shown. Install pivot bearing retainer in bottom of door using two 1/4-20x3/4" pan head machine screws and lockwashers.
- Laterally adjust center of pivot bearing retainer 2-5/8" (66.7) from outside edge of door (not including weatherstripping) and tighten screws firmly.

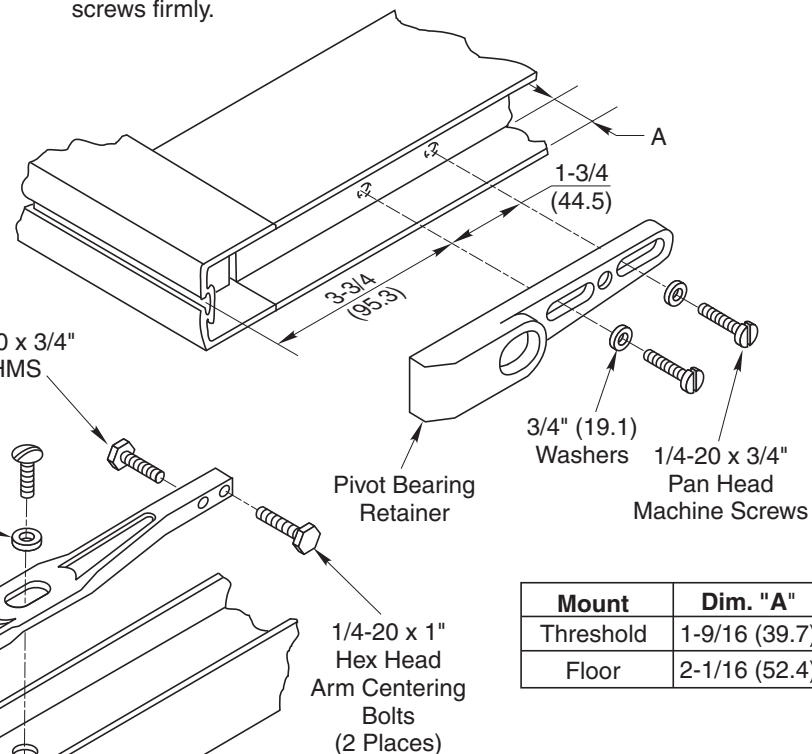

Mount	Dim. "A"
Threshold	1-9/16 (39.7)
Floor	2-1/16 (52.4)

#### Notes:

1. Do not scale drawing.
2. Double or single acting, center hung and side loading.
3. Door radius recommended 2-5/8" (66.7).
4. All dimensions given in inches (mm).

**608 Series Concealed Overhead Door Closers  
Double or Single Acting Aluminum Door & Frame  
Center Hung, Side Loading**

**RIXSON®**  
**ASSA ABLOY**

www.rixson.com

TEMPLATE NUMBER

**OC60430A**

DATE

**05-09**