

RIXSON®

ASSA ABLOY

Model 91 Overhead Concealed Closers Metal Frame Installation Instructions

*Butt or 3/4 Offset Pivot Hung, Multi Sized 1-3, 3-6
Non-Hold Open and Hold Open Models

*Other means except 4-1/2" x 4-1/2" or 3/4" offset pivot hung, consult factory.

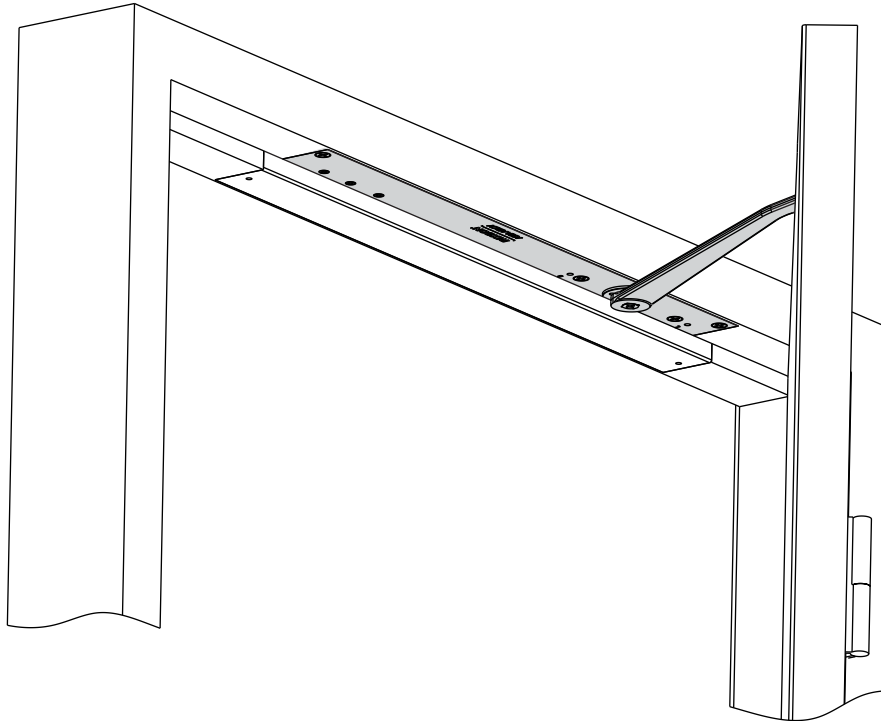

IMPORTANT:

- An improperly installed or incorrectly adjusted door closer may cause **property damage** or **personal injury** and will void product warranty.
- To avoid personal injury, **DO NOT DISASSEMBLE THIS DOOR CLOSER BODY.**
- Door closers must be securely fastened to a prepped door and frame with fasteners provided.
- HOLD OPEN option not permitted to be installed in fire door assemblies.

BEFORE INSTALLING:



- The Americans with Disabilities Act (ADA) requires that doors having door closers have an opening force not to exceed 5 lbf.
- The door closer's power size adjustment feature may require adjustment to its lowest setting to comply with ADA opening force guidelines.
- An auxiliary door stop, Rixson Checkmate surface applied overhead stops or others, is strongly recommended to avoid damage to the door closer and adjacent property.
- Doors should be hung on ball bearing or anti-friction hinges/pivots.
- **ADA compliant closers may not latch doors, manufacturer does not guarantee latching on lower opening force settings.**

TO DETERMINE HAND OF YOUR DOOR:

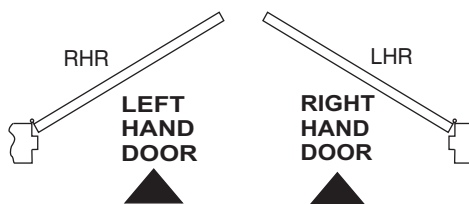

Max. Degree of Opening
91 Non Hold Open (135°) with Track Stop
91 Non Hold Open (180°) without Track Stop
91H Hold Open (105°)

A removable frame stop must be used in combination with the closer for proper installation. Mounting holes for frame stop must span closer length. Stop must be removable to install closer and make proper adjustments.

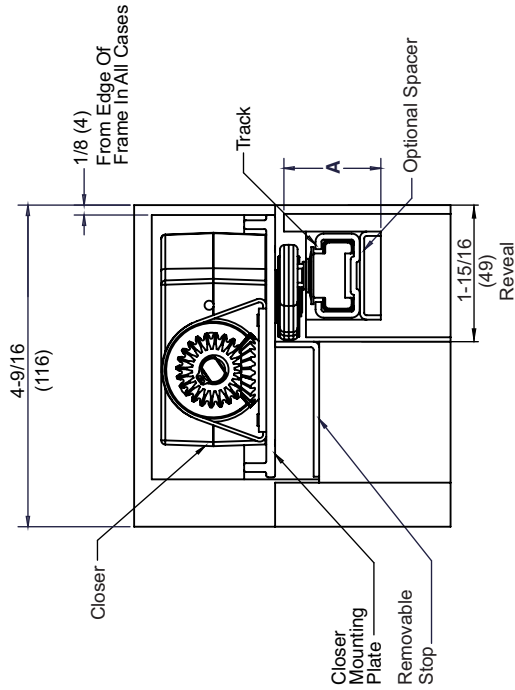

- Notes:
1. For 180° opening, max. allowable butt hinge size is 5" x 5".
 2. Min. stop thickness 1/2".
 3. 1/8" door to soffit clearance required.
 4. Reinforcing per ANSI/SDI-100 recommended for hollow metal doors and frames.
 5. Auxiliary stop recommended.
 6. Do not scale drawing.
 7. Dimensions given in inches (mm).

Left Hand Door and Closer Shown
Right Hand Opposite

"A" Dimension	Standard Application	Retrofit Track Option
	1-1/16" (27)	1-3/8" (35)

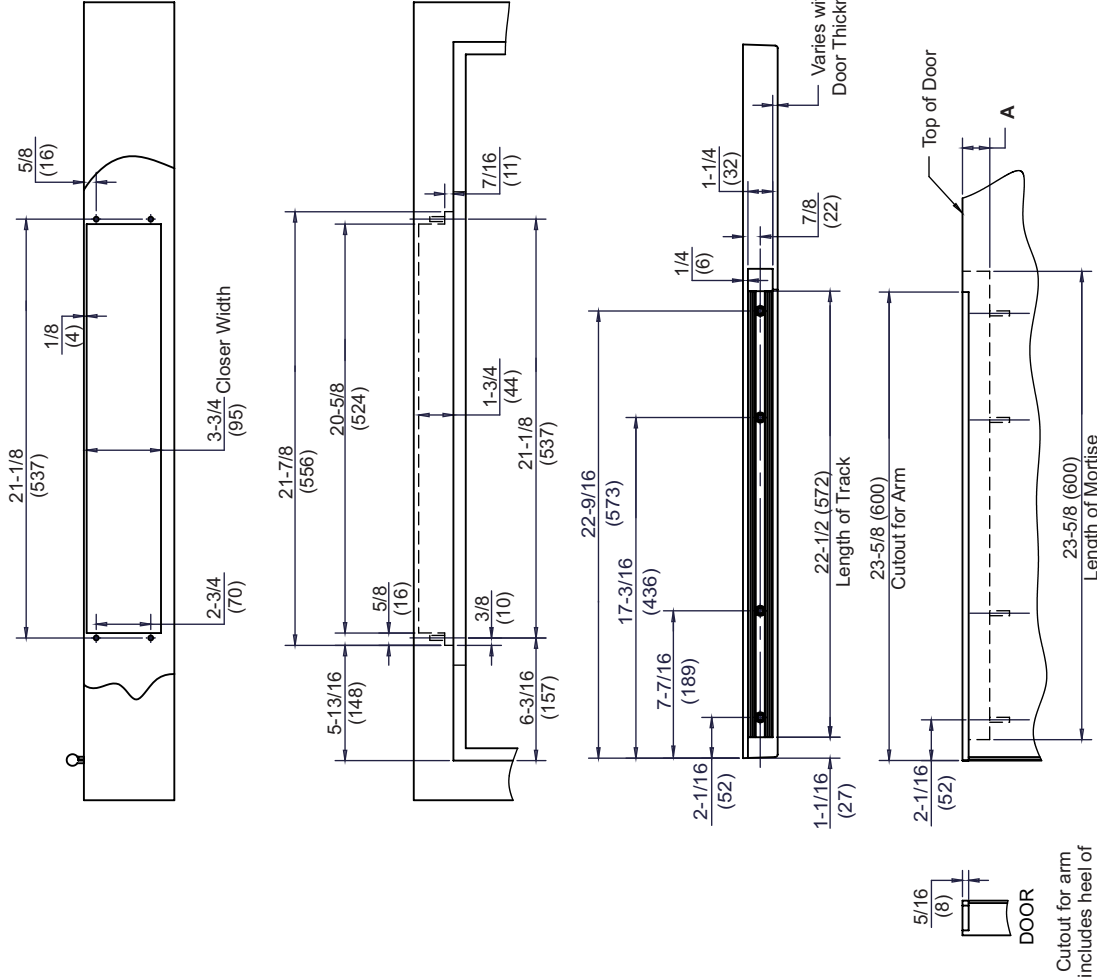

5/16 (8)
DOOR
Cutout for arm includes heel of door as shown.

Model 91 Overhead Concealed Closer
Butt Hinge, Metal Frame

RIXSON®
ASSA ABLOY
www.rixon.com

TEMPLATE NUMBER **OC60900** DATE **12/15**

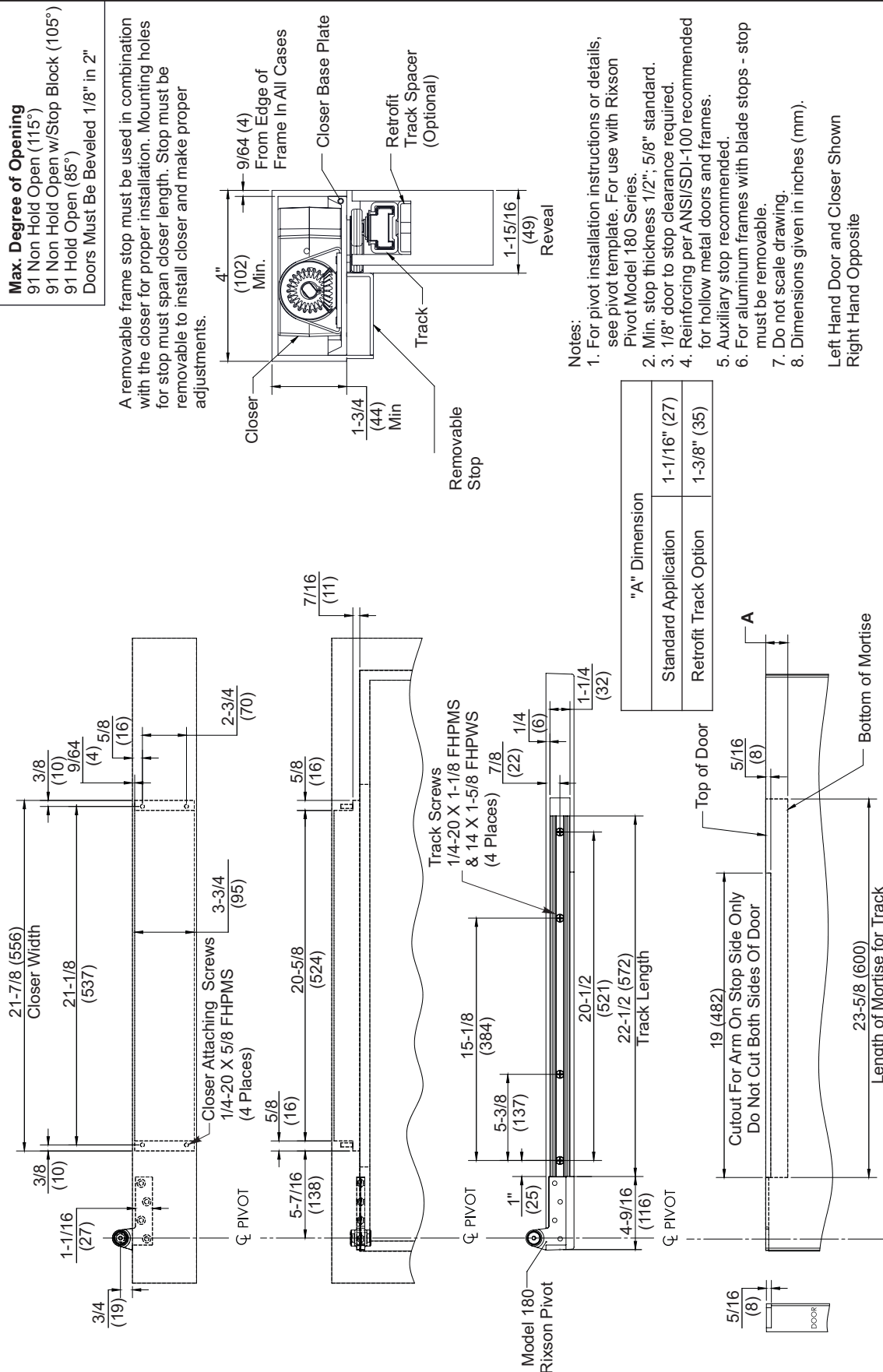

RIXSON
ASSA ABLOY
WWW.RIXSON.COM

TEMPLATE NUMBER **OC60912** DATE **11/15**

**Model 91 Overhead Concealed Closer
3/4" Offset Pivot Template**

Components:

Figure 1

Left hand shown

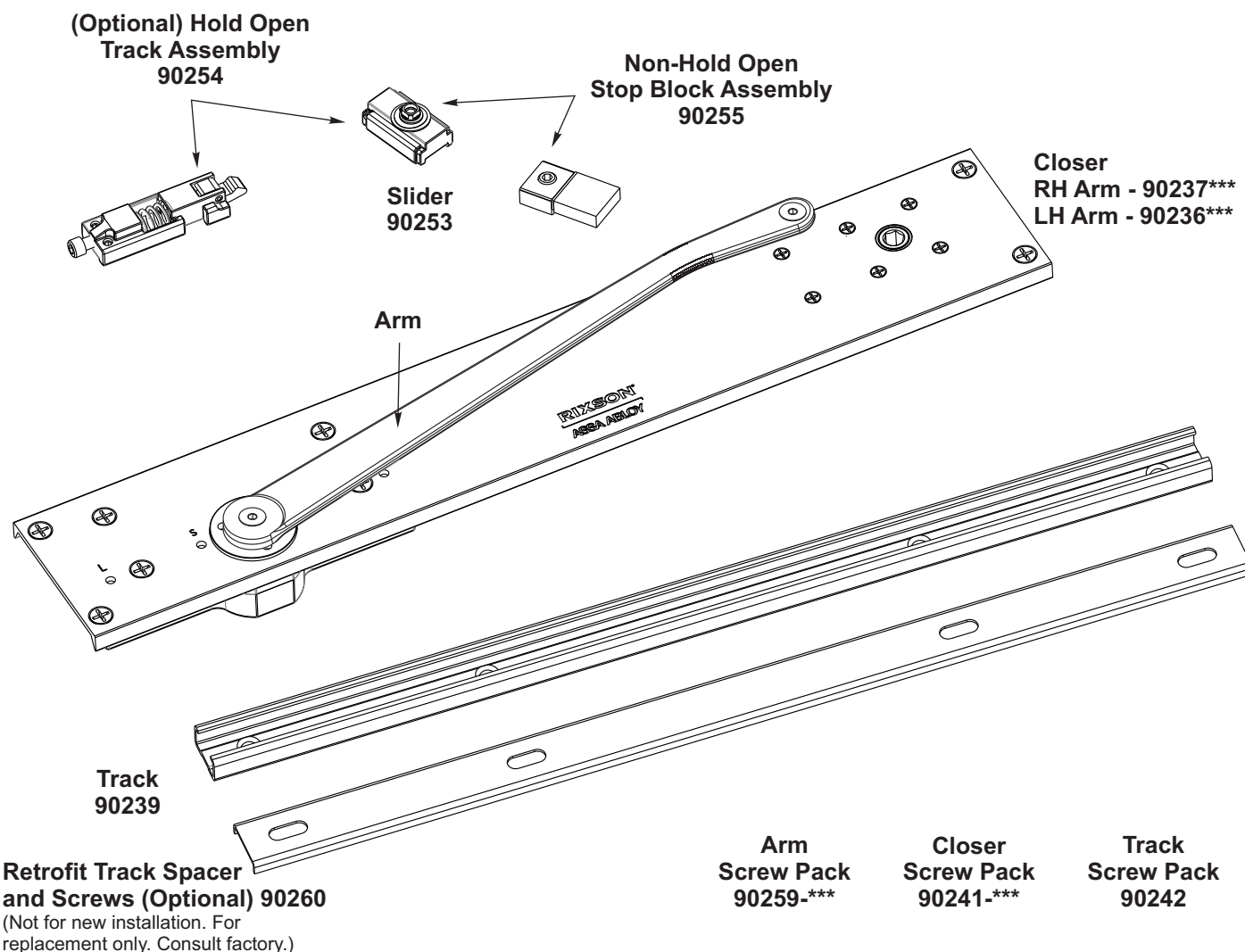

- It is recommended that the door, in which the door closer will be installed, be hung on ball bearing hinges or pivots. Door must swing freely. For other hanging means a special layout may be required, consult factory.
- A separate Rixson Surface Checkmate® or other door stop, supplied by others, is recommended to prevent damage to the door closer, closer arm; or to the door, frame or adjacent walls.
- Door and Frame must be reinforced for attaching screws.
- All dimensions are given in inches with corresponding metric dimensions (millimeters) in parentheses.

1 Verify Door Installation For Correctness

- Make sure the frame is plumb and square by using a carpenter's square.
- Note if the gaps between door and frame are consistent. Gap should be 1/16" at jamb and header.
- Using attached templates, check all dimensions of cut-outs.

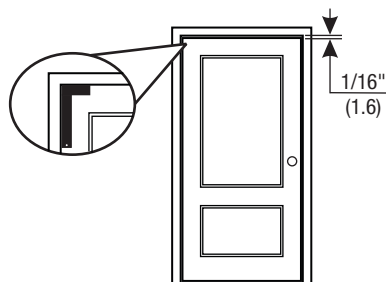

2 Closer Installation

- Left hand door illustrated.
- Install closer in prepped frame with (4) 1/4-20 x 5/8 FHPMS mounting screws provided. Mounting plate should be flush with frame soffit.

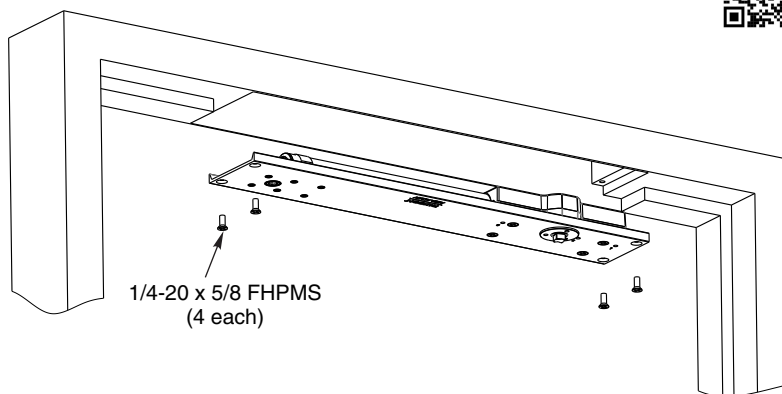

3 Check Arm Position

Arm Position Prior To Door Attachment

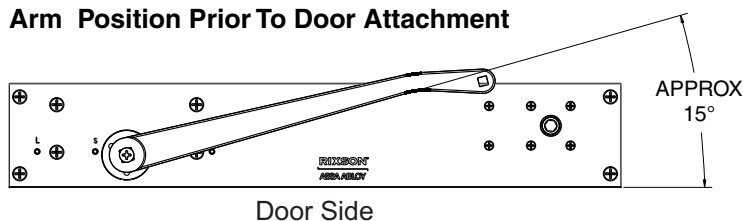

The arm should be at approximately 15 degrees away from the door side of the closer mounting plate prior to door attachment. Arm always rotates in direction of door.

4 Assembly of Track Components

- Slide track assembly components in track.
- Stop block assembly or (optional) hold open assembly should be mounted towards the hinge side of the track as shown. The longer end of the slider should be pointed towards the hinge end of the track.

Non Hold Open Track Assembly Install Components

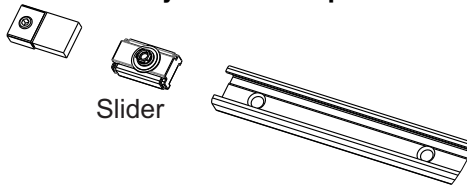

Slider

(Optional) Hold Open Track Assembly Install Components

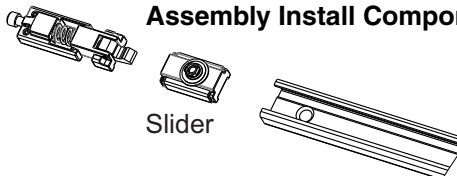

Slider



5 Track Installation

- Be sure to check that the slider and any track assembly components are installed prior to track installation.
- Install track and/or (optional) spacer (replacement application only, consult factory) using provided hardware in prepped door.

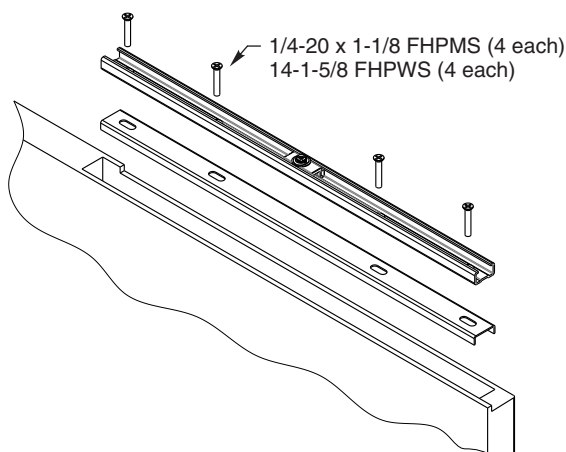

Long end of slider must be oriented toward the hinge/pivot end of door.

6 Closer/Door Attachment

1. With a 1/8" hex wrench, completely tighten the latch and sweep adjustments by turning the screws clockwise. This will allow for an easier closer/door connection.

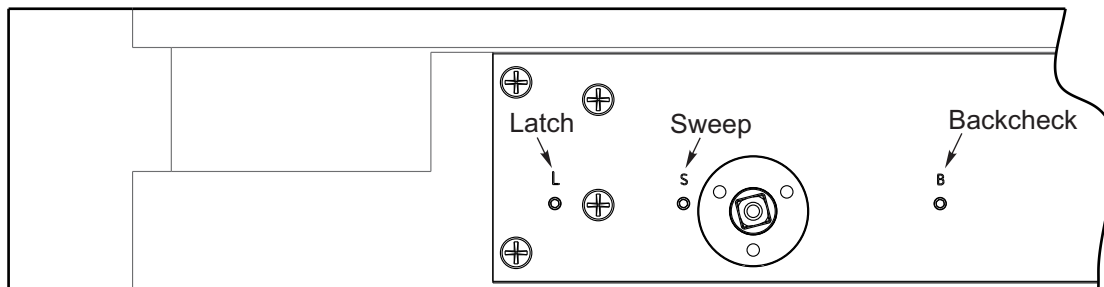

2. Open door to about 45 degrees then rotate arm over to door. The arm should maintain position since the latch and sweep adjustments have been closed.
3. Align slider square with arm square and connect the two using the provided screw. If you choose to open the door beyond 45 degrees, note that the backcheck adjustment screw may have to be adjusted counterclockwise to easily rotate arm to door position.

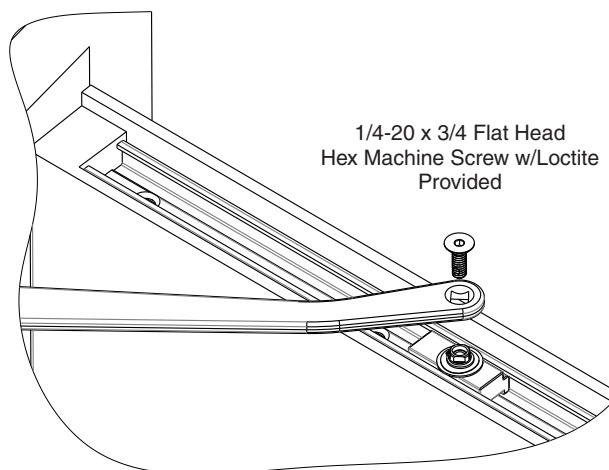

1/4-20 x 3/4 Flat Head Hex Machine Screw w/Loctite Provided

7 Closer Adjustments

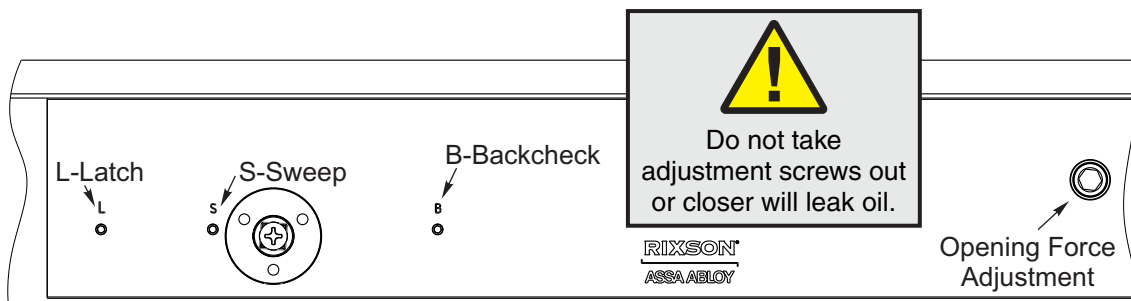

• Opening Force Adjustment

Locate opening force adjustment hex. Using 3/8" hex key, adjust opening force prior to sweep and latch adjustments. Size 1-3, 3-6 adjustment, see chart at right.

All 91 series closers are factory set to minimum opening force. Adjust closer as necessary for more closing force taking into consideration door size, weight, positive room pressure, etc. A lower opening force means a lower closing force. To achieve stronger closing forces, turn 3/8" hex clockwise. Keep in mind that the opening force will be increased as well.

Spring Adjustment			
Model PH91 Sizes 1-3		Model 91 Sizes 3-6	
Closer Size	Approx. # of Turns	Closer Size	Approx. # of Turns
ADA	0	3	0
1	15	4	17
2	30	5	25
3	55	6	32

Closer shipped at lowest spring setting.

After the opening/closing force has been set to satisfactory forces to close the door, adjust the sweep, latch and backcheck valves to control the speed of the door. Holes are shown in the mounting plate above to provide access to the adjustment valves using a 1/8" hex wrench.

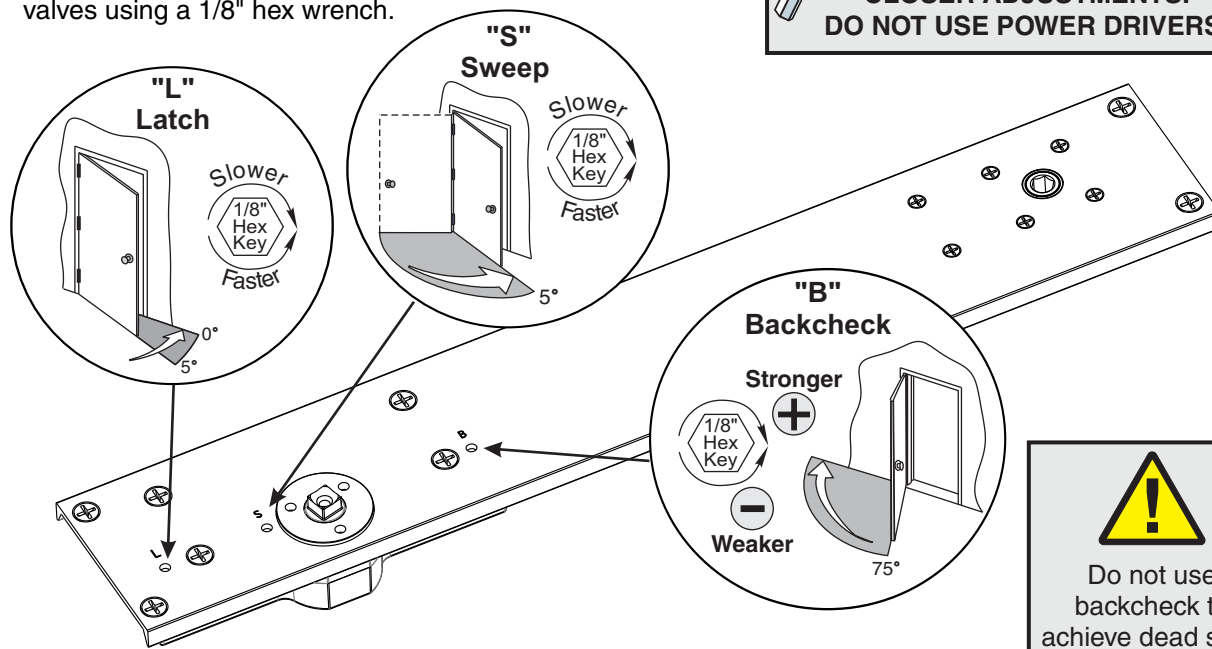

8 (Optional) Hold Open Adjustment

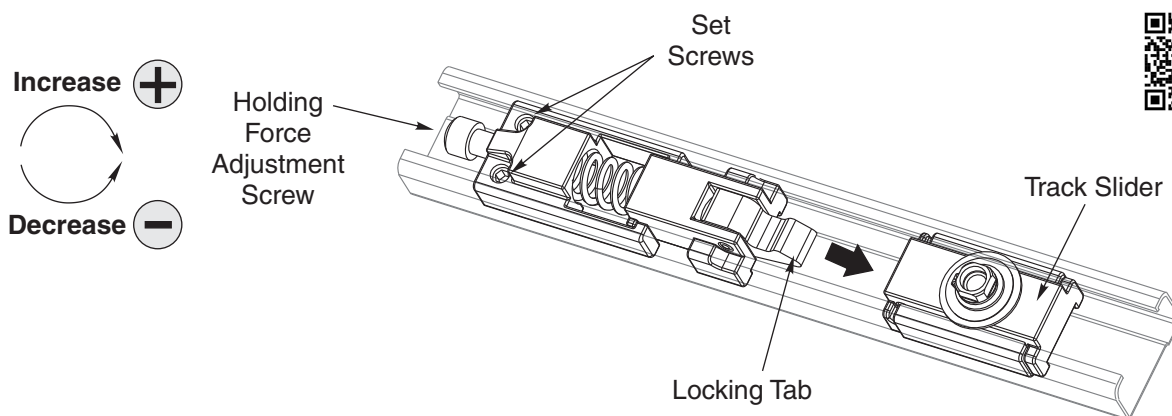

- Engage locking tab of hold open assembly in track slider. Hold open assembly should be on hinge side of track slider. Open door to desired hold open position. Tighten hold open mounting set screws to lock down hold open assembly. Pull door in the closing direction to disengage hold open assembly and track slider. To increase the amount of force necessary to pull door out of hold open, tighten the holding force adjustment screw clockwise. To decrease the amount of force necessary to pull door out of hold open, loosen the holding force adjustment screw counterclockwise.

NOTE: THIS FEATURE CANNOT BE USED ON FIRE-RATED DOORS

9 Removable Stop Installation

- After closer is installed and all adjustments are complete, install removable stop.

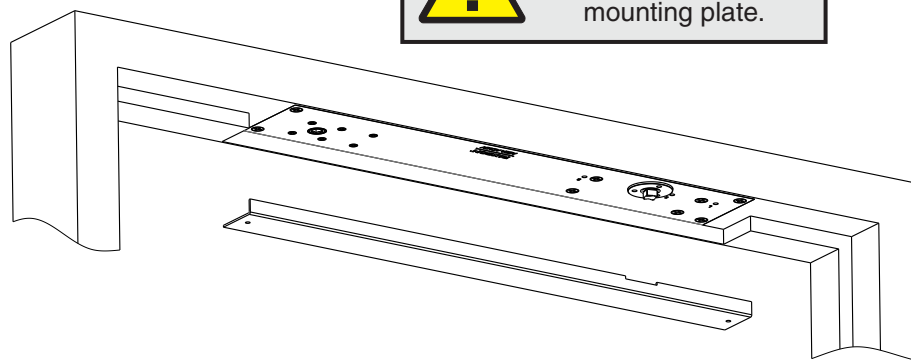
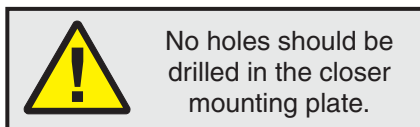

Troubleshooting

Symptom	Cause	Remedy
Door won't latch.	Spring tension not strong enough.	Use spring adjuster to increase tension. See Step 7.
	Latch speed control not fast enough.	Adjust latch speed valve. See Step 7.
	Door hung on products other than 4-1/2 x 4-1/2 butts or 3/4 offset pivots.	Send template for the hanging means to the factory. A new installation sheet is required. Closer will need to be relocated.
	Arm is not preloaded.	See Step 6.
Door is too difficult to open.	Spring tension is set too strong.	Use spring adjuster to decrease tension. See Step 7.

RIXSON®
ASSA ABLOY

3000 Highway 74 East • Monroe, NC 28112
 Tel: (866)-474-9766
 www.rixson.com