

CAUTION: Nicks and scratches on the magnet surface will lessen or diminish the holding force of the magnet. Do not remove protective cap, if present, until last steps of installation.

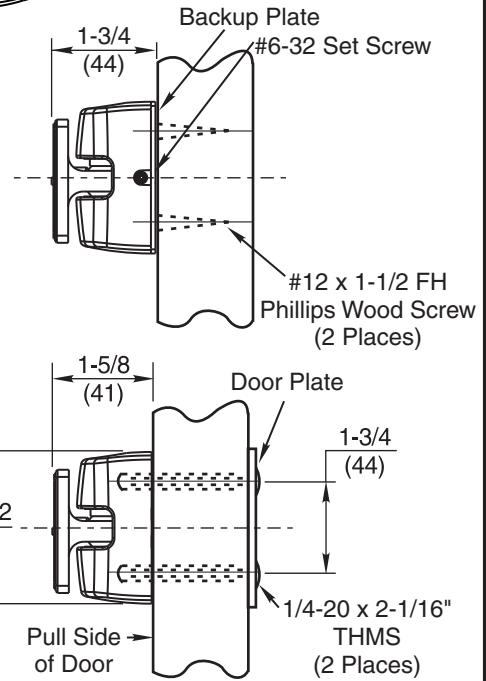
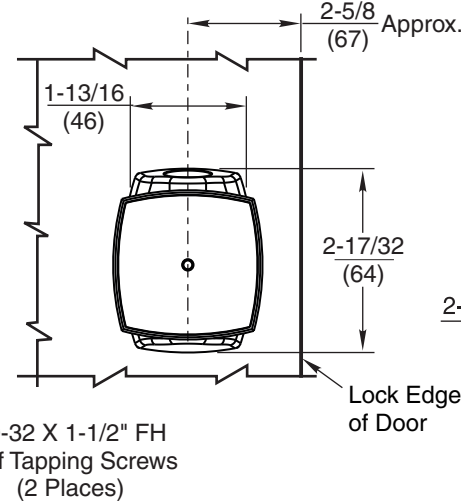
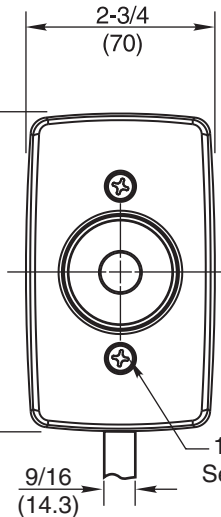
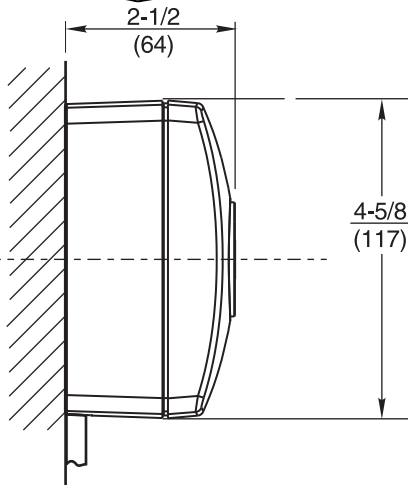
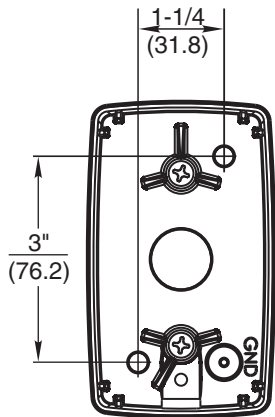

Notes:

1. Do not scale drawing.
2. Total projection 4-1/8" (105mm). (Includes surface adapter housing, electromagnet and armature assembly.)
3. Non-tri voltage magnets have two non-polarized wires to be connected. Tri voltage magnets are connected using a terminal strip on back of magnet. One wire in common and one wire in the appropriate voltage terminal (non-polarized). Ground surface adapter housing to earth ground per state and local electrical regulations using conductor provided.

4. See step 1 of sheet 2 for Surface Adapter Housing location. Anchor Housing to withstand a minimum 50 lb. pull. Surface Adapter Housing shown installed in a vertical position.
5. Door closing mechanism should have a 3 lb. closing force at the degree of door opening where door armature and electromagnet engage.
6. Mounting of Surface Adapter Housing should be reinforced to withstand shock of door opening. Failure to do so will cause Housing anchors to work loose.
7. All dimensions given in inches (mm).
8. See sheet 2 for more details.

996M Door Release

RIXSON

ASSA ABLOY

www.rixson.com

| | | |
|---------------|-----------------|----------|
| SHEET | TEMPLATE NUMBER | Rev |
| 1 of 2 | DR100255 | 1 |

1. Use table to locate Surface Adapter Housing.
2. Determine door width (Dim "B"). Measure pivot centerline to wall (Dim. "A"). Find dimension "C" in table.
 Example: Pivot centerline to wall ("A") = 10" (254mm)
 Door Width ("B") = 36" (914mm)
 Surface Adapter Housing Centerline ("C") = 33" (838mm)
3. If "A" or "B" falls between the numbers listed in table, allow for difference.
 Example: Pivot centerline to wall ("A") = 17" (432mm)
 Door Width ("B") = 36" (914mm)
 Surface Adapter Housing Centerline ("C") = 31" (787mm)

4. If dimensions "A" and "B" intersect in shaded area of table DO NOT INSTALL SURFACE ADAPTER HOUSING The degree of door opening will not permit proper alignment between armature and wall magnet.
5. Height to be determined by others. Suggested height is 2' to 4' (610mm to 1219mm) from floor and/or not over 6' (1829mm).
6. Check degree of door opening in table and coordinate with door closers and other door hardware.

Location of Surface Adapter Housing

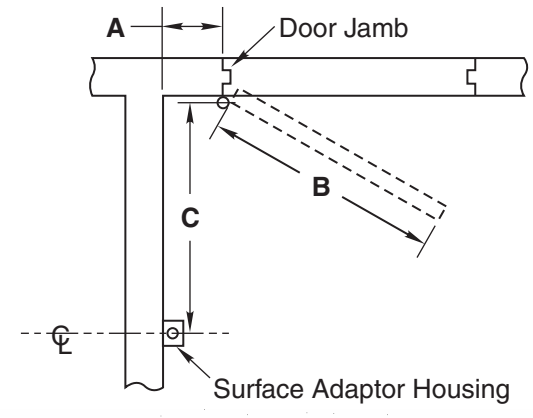

"A" – Door Jamb to Wall
 "B" – Door Width
 "C" – Pivot Centerline to Surface Adaptor Housing

Door Width "B"

| Dim. "A" | 28 | | 30 | | 32 | | 34 | | 36 | | 38 | | 40 | | 42 | | 44 | | 46 | | 48 | |
|----------|--------|------|--------|------|--------|------|--------|------|--------|------|--------|------|--------|------|--------|------|--------|------|--------|------|--------|------|
| | "C" | Deg. | "C" | Deg. | "C" | Deg. | "C" | Deg. | "C" | Deg. | "C" | Deg. | "C" | Deg. | "C" | Deg. | "C" | Deg. | "C" | Deg. | "C" | Deg. |
| 2 | 26 | 87° | 28-1/8 | 87° | 30-1/8 | 87° | 32-1/8 | 88° | 34 | 89° | 36 | 89° | 38 | 89° | 40 | 90° | 42 | 91° | 43-7/8 | 90° | 45-3/4 | 90° |
| 4 | 26 | 94° | 28-1/8 | 93° | 30-1/4 | 93° | 32-1/8 | 93° | 34 | 93° | 36 | 93° | 38 | 93° | 40 | 94° | 42 | 94° | 43-7/8 | 93° | 45-3/4 | 93° |
| 6 | 26 | 97° | 28 | 96° | 30 | 96° | 32 | 96° | 33-7/8 | 96° | 35-7/8 | 96° | 37-7/8 | 96° | 39-7/8 | 96° | 41-7/8 | 96° | 43-3/4 | 95° | 45-3/4 | 95° |
| 8 | 25-1/2 | 103° | 27-3/4 | 102° | 29-3/4 | 101° | 31-3/4 | 100° | 33-5/8 | 100° | 35-5/8 | 99° | 37-5/8 | 98° | 39-3/4 | 98° | 41-3/4 | 98° | 43-5/8 | 97° | 45-1/2 | 97° |
| 10 | 25-1/8 | 107° | 27-1/4 | 104° | 29-1/4 | 104° | 31-3/8 | 103° | 33-3/8 | 103° | 35-3/8 | 103° | 37-1/4 | 103° | 39-3/8 | 102° | 41-1/2 | 102° | 43-3/8 | 101° | 45-1/4 | 100° |
| 12 | 24-1/2 | 113° | 26-5/8 | 110° | 28-3/4 | 107° | 30-7/8 | 106° | 32-7/8 | 106° | 34-7/8 | 105° | 36-7/8 | 105° | 39 | 104° | 41-1/8 | 104° | 43 | 103° | 44-7/8 | 103° |
| 14 | 23-5/8 | 116° | 25-7/8 | 112° | 28 | 113° | 30-1/8 | 112° | 32-1/4 | 111° | 34-3/8 | 109° | 36-3/8 | 108° | 38-1/2 | 107° | 40-5/8 | 107° | 42-5/8 | 106° | 44-1/2 | 106° |
| 16 | 22-1/2 | 123° | 24-7/8 | 120° | 27-1/8 | 117° | 29-3/8 | 115° | 31-1/2 | 114° | 33-5/8 | 113° | 35-3/4 | 112° | 38 | 111° | 40-1/8 | 110° | 42 | 109° | 43-7/8 | 108° |
| 18 | 21-1/4 | 127° | 23-3/4 | 125° | 26-1/8 | 122° | 28-3/8 | 120° | 30-1/2 | 117° | 32-3/4 | 116° | 34-7/8 | 115° | 37-1/8 | 114° | 39-1/4 | 113° | 41-1/4 | 112° | 43-1/8 | 112° |
| 20 | 19-3/4 | 133° | 22-1/4 | 130° | 24-3/4 | 126° | 27-1/8 | 123° | 29-1/2 | 121° | 31-3/4 | 119° | 34 | 117° | 36-1/4 | 116° | 38-1/2 | 116° | 40-1/2 | 115° | 42-3/8 | 114° |
| 22 | | | | | 24-1/4 | 132° | 25-3/4 | 126° | 28-1/4 | 125° | 30-5/8 | 123° | 32-7/8 | 122° | 35-1/4 | 120° | 37-1/2 | 118° | 39-5/8 | 117° | 41-5/8 | 116° |
| 24 | | | | | | | 24-3/8 | 129° | 26-7/8 | 129° | 29-3/8 | 127° | 31-7/8 | 125° | 34-1/4 | 123° | 36-5/8 | 122° | 38-3/4 | 120° | 40-7/8 | 118° |
| 26 | | | | | | | 22-5/8 | 133° | 25 | 134° | 27-5/8 | 130° | 30-1/4 | 127° | 32-3/4 | 126° | 35-1/4 | 125° | 37-1/2 | 123° | 39-5/8 | 122° |
| 28 | | | | | | | | | | | 25-7/8 | 133° | 28-1/2 | 133° | 31-1/4 | 130° | 33-7/8 | 127° | 36-1/8 | 125° | 38-1/4 | 124° |
| 30 | | | | | | | | | | | | | | | 29-1/4 | 132° | 32-1/8 | 132° | 34-1/2 | 129° | 36-3/4 | 127° |
| 32 | | | | | | | | | | | | | | | | | | | 33 | 132° | 35-1/2 | 131° |

All dimensions given in inches.

996M Door Release Location Sheet

RIXSON

ASSA ABLOY

www.rixson.com

| | | |
|---------------|-----------------|----------|
| SHEET | TEMPLATE NUMBER | Rev |
| 2 of 2 | DR100255 | 1 |