

How To Determine Hand of Door

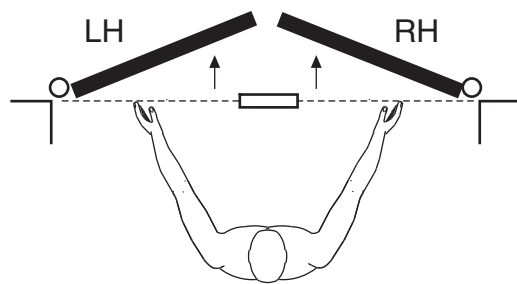

Face a door swinging open away from you. If it opens to the right, it is right hand. If it opens to the left, it is left hand.

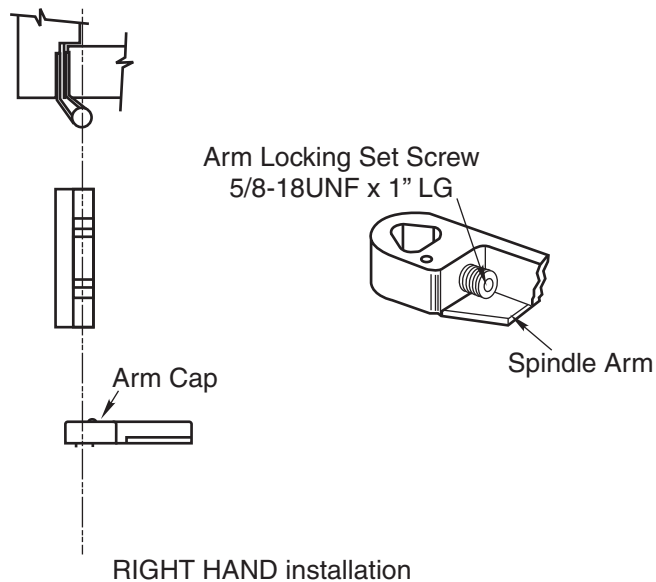

Installation Instructions

1. Install Closer

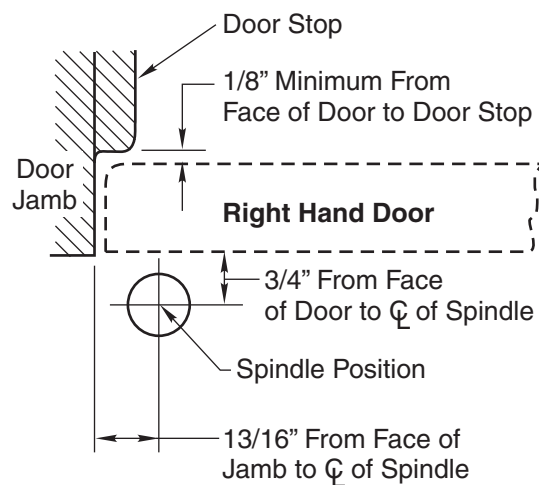

- Measure 13/16" out from door jamb.
- Allow 1/8" minimum clearance from door stop to door face. Measure door thickness. Add 3/4".
- Where lines meet determines center line of closer.

2. Install Cement Case in Floor

LEVEL IN BOTH DIRECTIONS

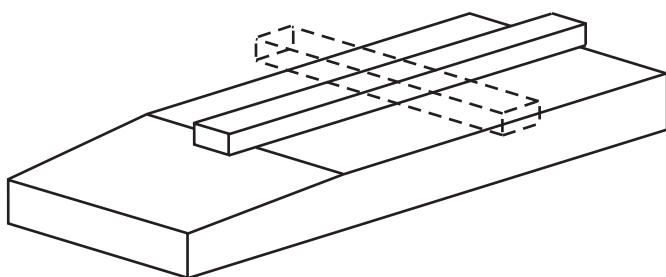

- Cement case is set flush with floor.
- Set cement case in floor and block in position.
- Case should be parallel with center line of door.
- CEMENT CASE MUST BE LEVEL.** Place levels per illustration.
- Grout in cement case with closer. Cement should not get between closer and case.

3. Install Offset Hinges

4. Hang Door

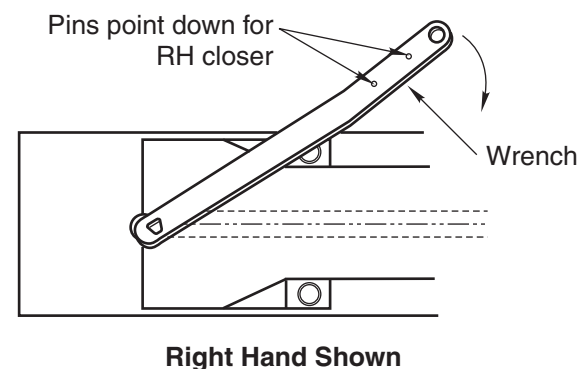

Right Hand Shown

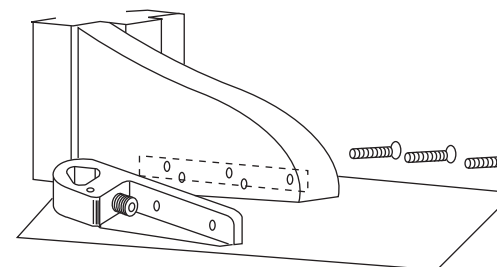
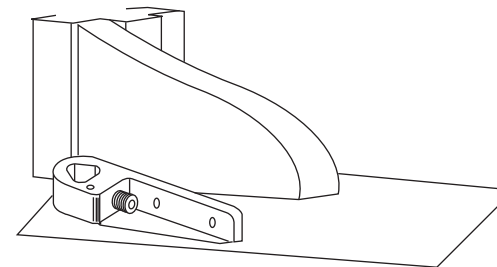

Center line of hinge should line up with center line of spindle. Use plumb line. If center lines don't line up, loosen hold down screws (4) and reposition closer. Tighten hold down screws closest to spindle first. Then tighten screws at cylinder end. Note: Closer must be lifted approximately 1/8" before repositioning.

CAUTION: Closer is shipped with "Stroke" valve down. DO NOT FORCE VALVE DOWN.

- Turn spindle until wrench is parallel with center line of closer.
- Slip arm on spindle and spot arm mounting holes.
- Drill three (3) 3/8" diameter holes in door for arm mounting screws.
- Attach arm as shown.
- Open Closing Speed and Latch Speed valves (counterclockwise) one turn. Door will then close.