

Installation Instructions

73022 (04-09)

Blocking Instructions

Check template for location of rough hole.

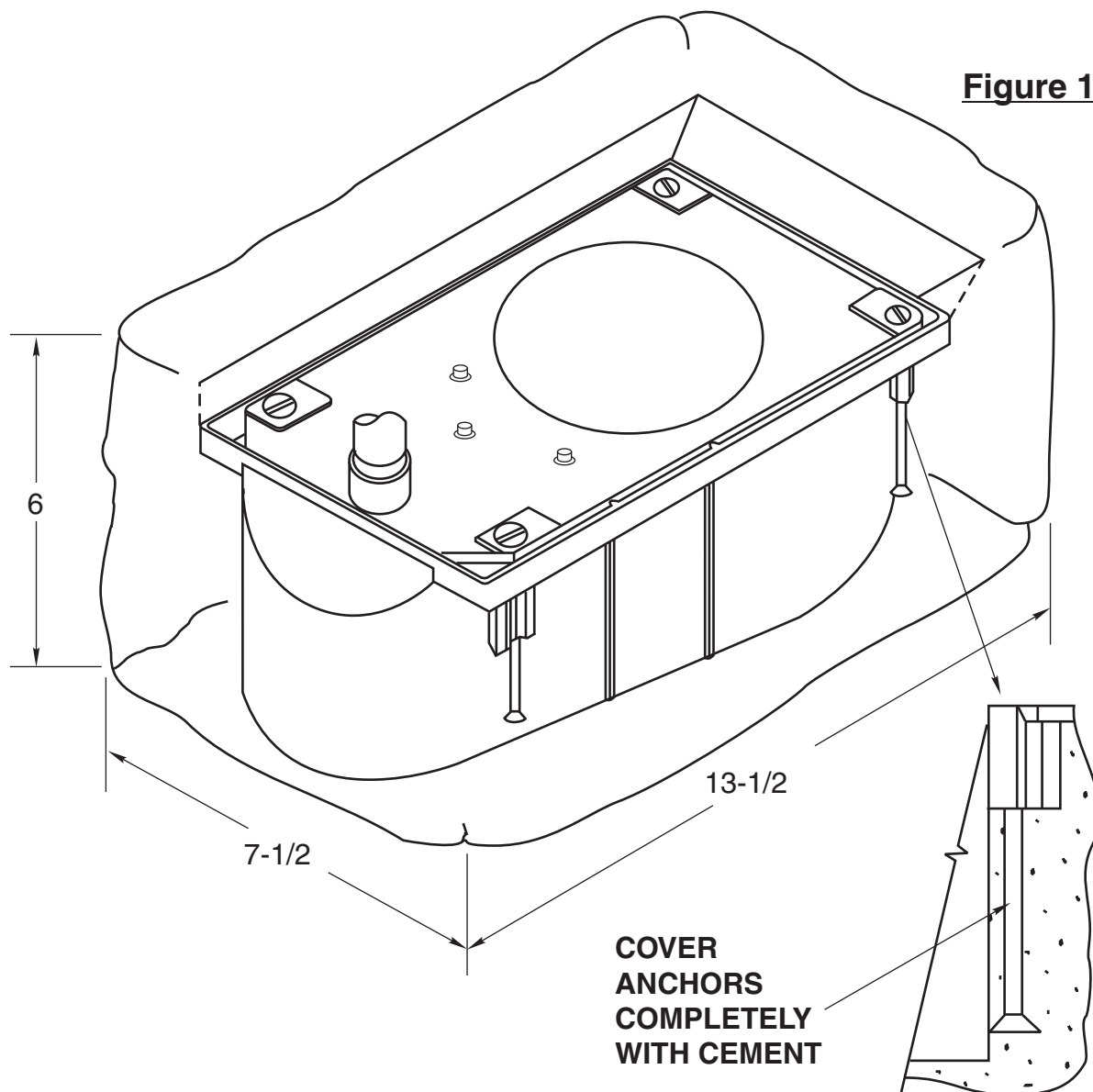

Figure 1A

Note:

1. Do not scale drawing.
2. Dimensions given in inches. Conversion from inches to metric: inch x 25.4.
3. If necessary to prevent cement from entering foundation case, apply duct tape to seal the gap between closer and foundation case.

Kit includes:

- 4 ea 1/4 -20 x 3/4 Flat Head Phillips Screws
- 4 ea #10-24 x 5/16 Round Head Phillips Screws
- 4 ea #10-24 x 3/4 Hex Washer Head Screws
- 2 ea Straps
- 1 Spindle locator 3/4 offset
- 1 Spindle locator 2-3/4 center hung
- 1 Bubble level

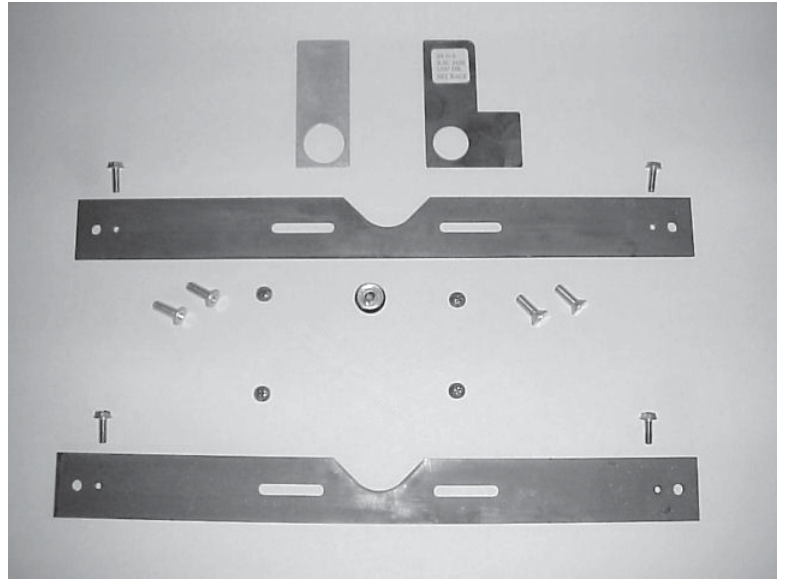

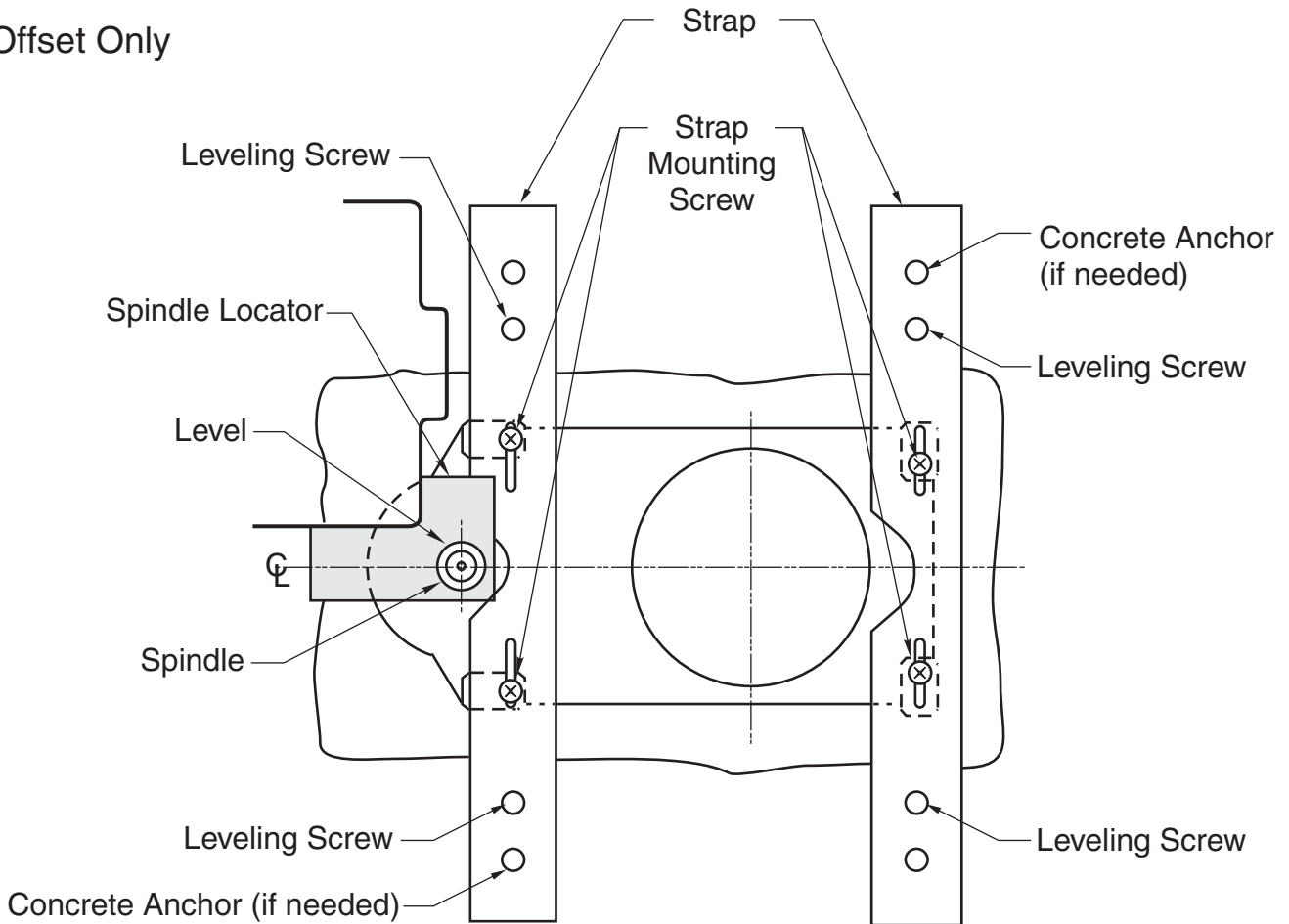

**No. Q27 or QT27
Offset Closers
Right Hand Shown**

3/4 Offset Only



Installation:

1. With frame set in place, cut hole in floor to dimensions for closer model on page 1; Figure 1. Clean out excess concrete.
2. Install top pivot in frame. 
3. Drop plumb line from top pivot. See Figure 2 at right. (Use of Rixson 2604 Pivot Aligning Tool is recommended) 
4. Place closer in cement case and attach with 4 each 1/4-20 x 3/4 Flat Head Phillips screws.
5. Place straps on top of cement case and center each.
6. Using 10-24 x 5/16 round head screws, tighten straps to top of closer. See Figure 3 at right.
7. Set closer/foundation case in hole in floor.
8. Put spindle locator over spindle and position closer next to frame. See closer model illustration on page 2.
9. Make sure that plumb line is centered over spindle.
10. Place bubble level on top of closer spindle and torpedo level. See Figure 4 at right.
11. Using 4 leveling screws (10-24 x 3/4 hex washer head screws), turn screws to raise and lower straps until closer is completely level. This is determined by bubble level provided.
12. Re-check all areas, locator, plumb line and level.
13. If needed, insert cement anchors to stabilize installation.
14. Use two pour grouting procedure:
Step 1 Use EXPANDABLE QUICKSET CEMENT, (Por-Rok or equivalent grout). Grout in only bottom 3/4" of foundation case, including bottom of cement anchor. Allow grout to harden.
15. Hang door.
16. **Step 2** Use a regular cement mixture, EXTERIOR TYPE (Sakrete or equivalent) to finish setting the foundation case. ALL 4 ANCHORS MUST BE COMPLETELY COVERED WITH CEMENT. (See Figure 1A on page 1)

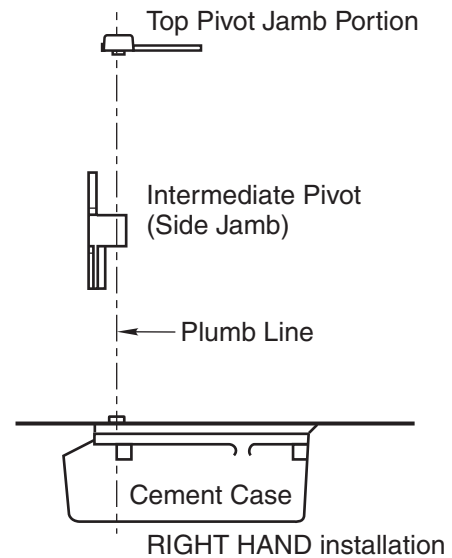

Figure 2

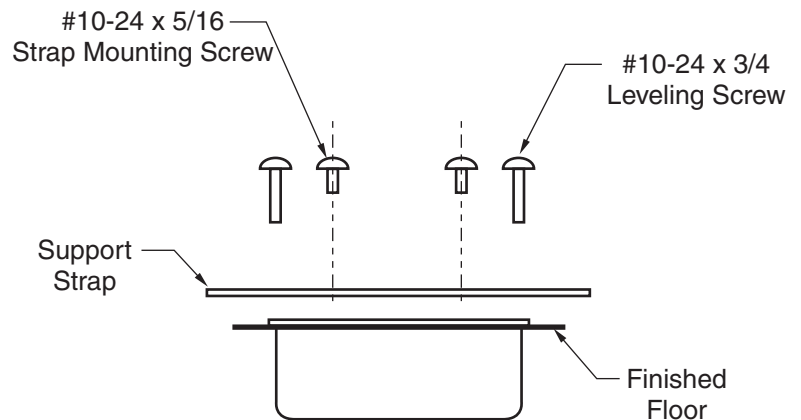

Figure 3

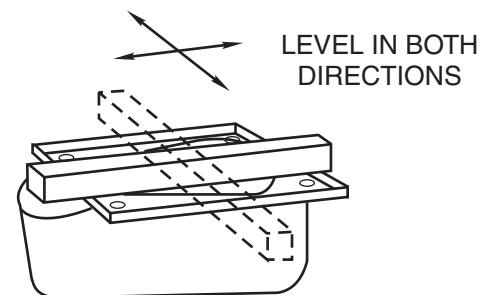

Figure 4

ASSA ABLOY is the global leader in door opening solutions, dedicated to satisfying end-user needs for security, safety and convenience.

Rixson® is a registered trademark of Yale Security Inc., an ASSA ABLOY Group company. Copyright© 1988, 2009, Yale Security Inc., an ASSA ABLOY Group company. All rights reserved. Reproduction in whole or in part without the express written permission of Yale Security Inc. is prohibited.