

INSTALLATION INSTRUCTIONS

Concealed Pin and Barrel Continuous Hinge SL3500



PRODUCT MUST BE INSTALLED ACCORDING TO ALL APPLICABLE BUILDING AND LIFE SAFETY CODES

All holes in door and frame must be drilled correctly and fasteners properly installed. Failure to use fasteners supplied by Select Products Limited will void UL or WHI fire rated listing.

Important Warranty Information:

The following actions will void any warranty, expressed or implied:

- Failure to install the hinge according to the manufacturer's specifications and requirements. (for more information, visit selecthingerequirements.com)
- Use of fasteners other than those supplied with the hinge.
- Unauthorized field modifications, including alteration of the original finish or painting the hinge.

1: Frame Preparation

- A. Place the hinge frame leaf on the frame. Position the top of the hinge 1/8" maximum below the header as shown (Fig.1). Place the hinge firmly against the rabbet of the frame.
- B. Mark and center punch each hole on the frame with the hinge held firmly in place. For ease of installation, a center punch can help center the hole so that the fasteners will enter straight. Remove the hinge from the frame and prepare to drill the frame.
- C. Drill holes:
 - Wood frame:** Drill all holes using a #28 or 9/64" drill bit
 - Hollow Metal frame:** Drill all holes using a #16 drill bit. If hollow metal frame is reinforced, thread all holes with #12-24 tap.

Do not attach the hinge to the frame at this time.

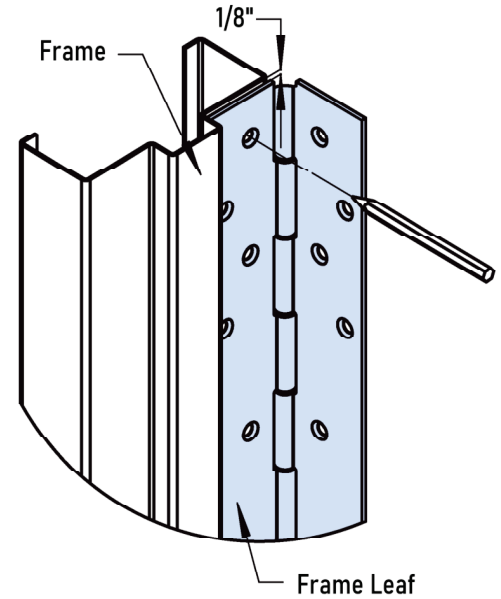

Fig. 1

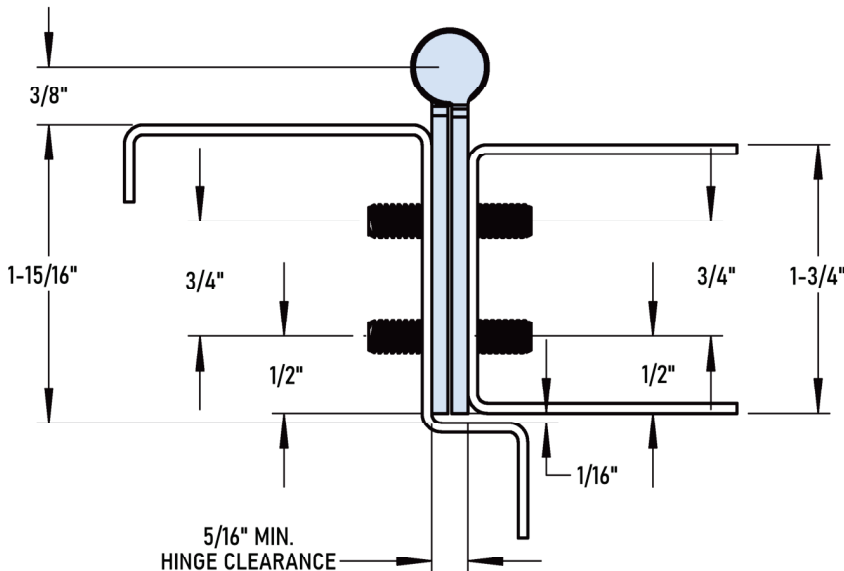

Fig. 2

STANDARD HARDWARE	
#12-24 X 7/16" FLAT HEAD UNDERCUT MACHINE SCREW (MS1244SP10SS)	
OPTIONAL HARDWARE AVAILABLE UPON REQUEST	
#12-8 x 1-1/2" FLAT HEAD UNDERCUT WOOD SCREW (PBS12150SP10SS)	
SECURITY SCREWPACKS M91-0031MM, M91-0031MW, M91-0031WW	

Step 2: Door Preparation

A. Position the hinge door leaf so that the top of the hinge is flush with the top of the door. Next make sure the hinge edge is up flush with the door face.

B. Mark and center punch each hole on the door with the hinge held firmly in place (Fig.2). Remove the hinge from the door and prepare to drill the door.

C. Drill holes:

Wood Doors: Drill all holes using a #28 or 9/64" drill bit.

Hollow Metal Doors: Drill all holes using a #16 drill bit. If hollow metal door is reinforced, thread all holes with #12-24 tap.

Step 3: Hinge Installation

A. Attaching hinge to door (Fig.3)

Wood: Attach hinge using #12-8 x 1-1/2" Flat Head Wood Screws

Hollow Metal: Attach hinge using #12-24 x 7/16" Flat Head Undercut Machine Screws

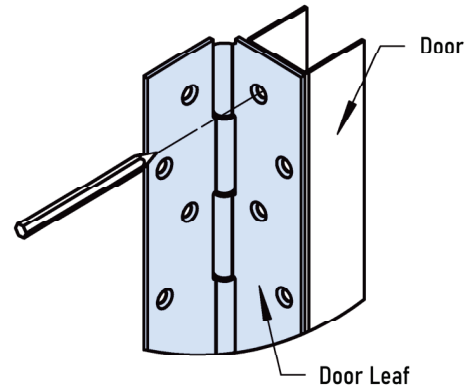

Fig. 3

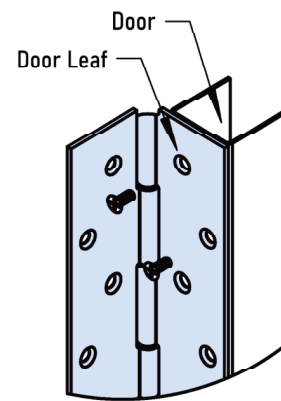

Fig. 4

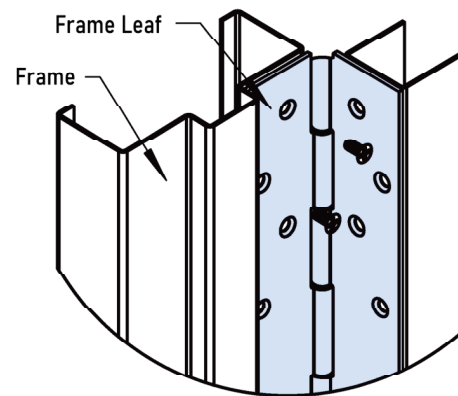

Fig. 5

Model SL3500

Standard "Non-Adjustable" application clearances

Total Under-Sizing Required

Door Edge	Clearance (A)	Single Door	Pair of Doors
Square	5/16"	1/2"	13/16"

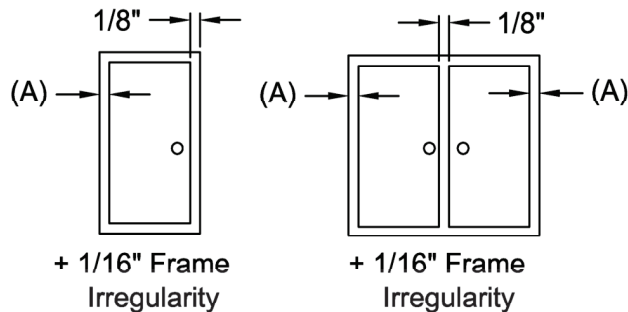

SELECT HINGES®
SELECT Products Limited

3258 Stadium Park Way
Kalamazoo, MI 49009
PH: 800-423-1174
Fax: 800-423-7107
www.select-hinges.com

F-02-17-08-20