

Enclosure Installation Considerations

What is Torque?

Torque is the tendency of a force to rotate an object about an axis. Just as a force is a push or pull, a torque can be thought of as a twist.

Loosely speaking, torque is a measure of the turning force on an object such as a bolt. The unit of measure is generally expressed in foot pounds or inch pounds

The formula for torque is:

$$\tau = r \times F$$

where:

τ is the torque

r = the length of the lever arm

F = the force

Properly fastened threaded products achieve their holding power from the tension (or torque) that is derived from the mating of the external and internal threads subject to the elastic limit of the material.

What torque to apply is a generally asked question, but the answer depends on the variables of material, threads' class of fit, method of thread manufacture, and thread lubrication - if any.

Table 3 is offered as the suggested maximum torque values for threaded products. The table is only a guide. Actual tests were conducted on dry, or near dry, products. Mating parts were wiped clean.

Table 3 – Strength Characteristics

Bolt Size	18-8 SS	Brass	Silicon Bronze	Aluminum 2024-T4	316 SS	Monel	Nylon*
	In. Lbs.	In. Lbs.	In. Lbs.	In. Lbs.	In. Lbs.	In. Lbs.	In. Lbs.
2-56	2.5	2.0	2.3	1.4	2.6	2.5	.44
2-64	3.0	2.5	8.0	1.7	3.2	3.1	
3-48	3.9	3.2	3.6	2.1	4.0	4.0	
3-56	4.4	3.6	4.1	2.4	4.6	4.5	
4-40	5.2	4.3	4.8	2.9	5.5	5.3	1.19
4-48	6.6	5.4	6.1	3.6	6.9	6.7	
5-40	7.7	6.3	7.1	4.2	8.1	7.8	
5-44	9.4	7.7	8.7	5.1	9.8	9.6	
6-32	9.6	7.9	8.9	5.3	10.1	9.8	2.14
6-40	12.1	9.9	11.2	6.6	12.7	12.3	
8-32	19.8	16.2	18.4	10.8	20.7	20.2	4.3
8-36	22.0	18.0	20.4	12.0	23.0	22.4	
10-24	22.8	18.6	21.2	13.8	23.8	25.9	6.61
10-32	31.7	25.9	29.3	19.2	33.1	34.9	8.2
1/4"-20	75.2	61.5	68.8	45.6	78.8	85.3	16.0
1/4"-28	94.0	77.0	87.0	57.0	99.0	106.0	20.8
5/16"-18	132	107	123	80	138	149	34.9
5/16"-24	142	116	131	86	147	160	
3/8"-16	236	192	219	143	247	266	
3/8"-24	259	212	240	157	271	294	
7/16"-14	376	317	349	228	393	427	
7/16"-20	400	327	371	242	418	451	
1/2"-13	517	422	480	313	542	584	
1/2"-20	541	443	502	328	565	613	
9/16"-12	682	558	632	413	713	774	
9/16"-18	752	615	397	456	787	855	
5/8"-11	1110	907	1030	715	1160	1330	
5/8"-18	1244	1016	1154	798	1301	1482	
3/4"-10	1530	1249	1416	980	1582	1832	
3/4"-16	1490	1220	1382	958	1558	1790	
7/8"-9	2328	1905	2140	1495	2430	2775	
7/8"-14	2318	1895	2130	1490	2420	2755	
1"-8	3440	2815	3185	2205	3595	4130	
1"-14	3110	2545	2885	1995	3250	3730	
	Ft. -Lbs.	Ft. -Lbs.	Ft. -Lbs.	Ft. -Lbs.	Ft. -Lbs.	Ft. -Lbs.	
1-1/8"-7	413	337	383	265	432	499	
1-1/8"-12	390	318	361	251	408	470	
1-1/4"-7	523	428	485	336	546	627	
1-1/4"-12	480	394	447	308	504	575	
1-1/2"-6	888	727	822	570	930	1064	
1-1/2"-12	703	575	651	450	732	840	

*Nylon figures are breading torque, all others represent safe working torque.

The 3/8" diameter and under metal products were roll-threaded and, where size range permitted, were made on automatic bolt making equipment.



Torque Formula Illustrations

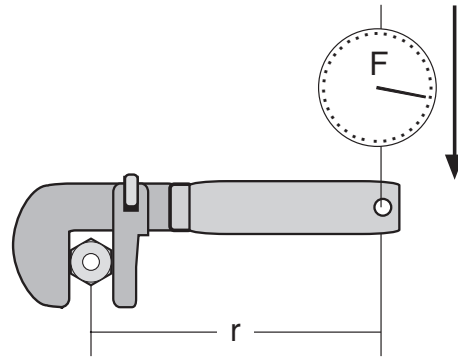
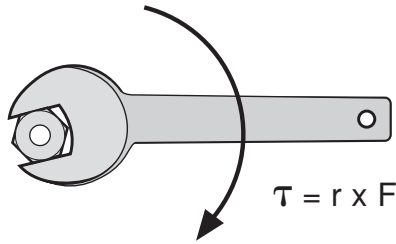

Methods For Making Holes And Cutouts In Non-Metallic Enclosures

Drilling of composite fiberglass material has been difficult and, for some, a mystery. The ability to accurately drill holes in composite fiberglass material has been the subject matter of numerous articles and how to demonstrations. There are several types of machining operations that can be performed on composites such as turning, drilling, routing, trimming, sanding, and milling. Most of these operations are similar to metal removal techniques but there are some differences that need to be addressed in order to make clean, high quality holes and cutouts in composites.

Delaminating of the outer surface and glass fibers directly below the surface are the main failure modes noticed when holes or cutouts are drilled or cutout improperly. Most times excessive edge chipping around the perimeter of the cutout or hole is due to improper tools used and methods applied. Other times excessive fiber pulls or attached fibers not sheared off during the cutting or turning process can also cause delamination failure from the tearing action during material removal. Improper tools used and/or methods are also a culprit of this failure mode. All these can lead to downstream assembly problems, functionality problems, and become aesthetically unappealing if taken to the extreme.

The most common source of failure mode when making holes in an enclosure is a dull cutting tool. Dull tools tend to rip or tear the material rather than cutting or shearing the material and glass fibers. The main culprit for tools becoming dull is glass fibers embedded in the material. These glass fibers are very abrasive and can cause a tool to become dull very quickly. A little planning and understanding of the proper methods to machining composites up front can make all the difference in the final outcome of the operation.

Figure A shows delamination of the surface of the part at the drill entrance.

Figure B shows similar delamination just prior to drill exit.

