

FOR ADDITIONAL INFORMATION SEE TEMPLATE NO. 10158 OR NO. 10172

NOTE: TYPE 86 STOCK HOLLOW METAL APPLICATIONS FOR 88 DEVICES WILL WORK WITH ALL STANDARD STRIKE APPLICATIONS. SEE CORRESPONDING 88 DEVICE TEMPLATE FOR CORRECT BACKSET AND DEVICE HEIGHT.

TYPE 86 STOCK HOLLOW METAL DOOR & STD DOOR

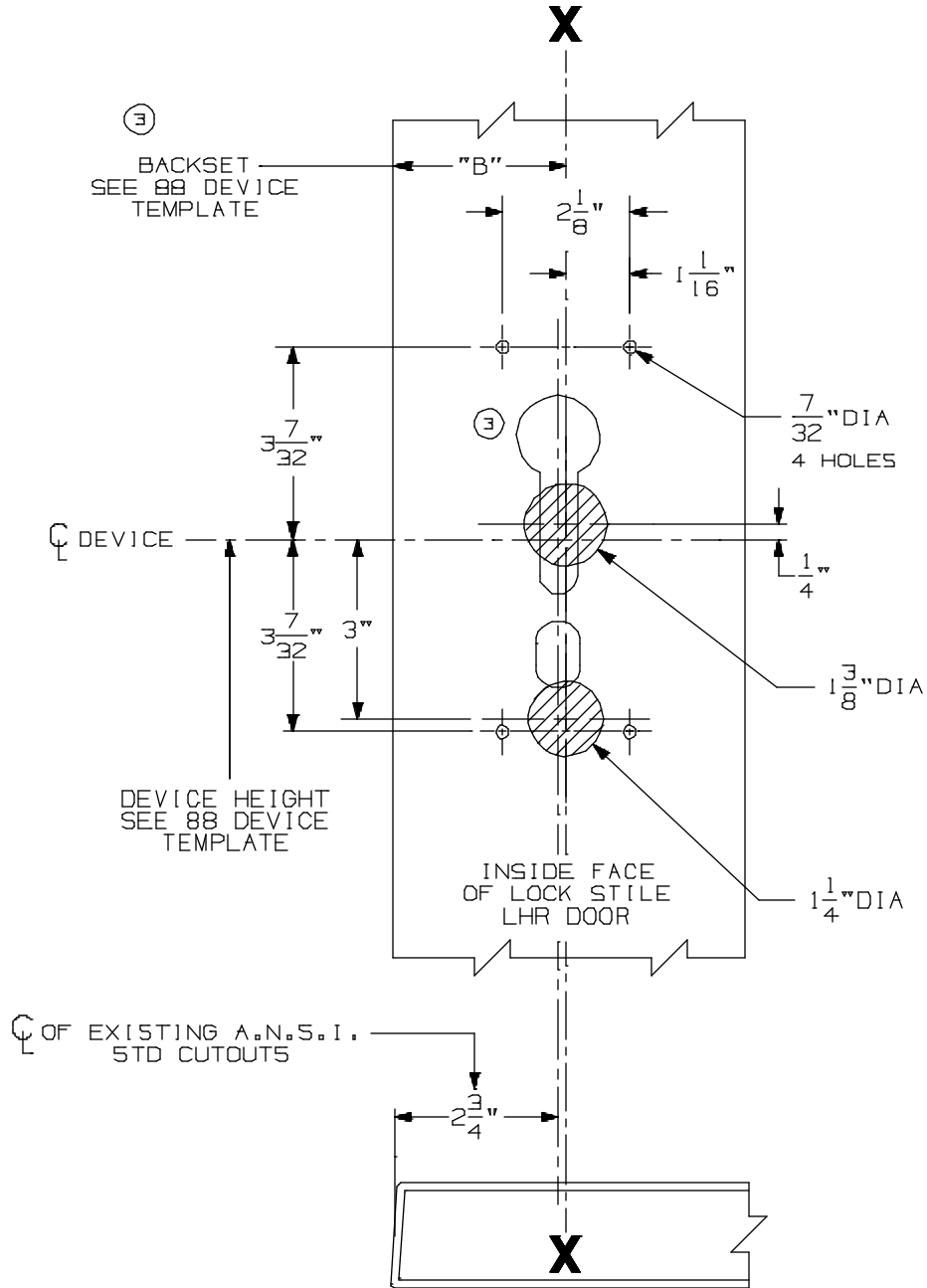

SEE A.N.S.I. SPECIFICATION NO. A115 FOR THE SIZE AND LOCATION OF STOCK CUTOUTS.

FOR OUTSIDE TRIM PREPARATION, SEE ADDITIONAL TRIM TEMPLATE.

LHR SHOWN
RHR OPPOSITE

88K Rim Devices w/ 880 Trim for Type "86"
Stock Hollow Metal Applications

VON DUPRIN®

NOTES: SEE MASTER SHEET #10001 FOR SUGGESTED REINFORCING

TEMPLATE NUMBER:

10205_a

DATE:
05-16-13