

VON DUPRIN®

Auxiliary
hardware
& general
information

Exit devices

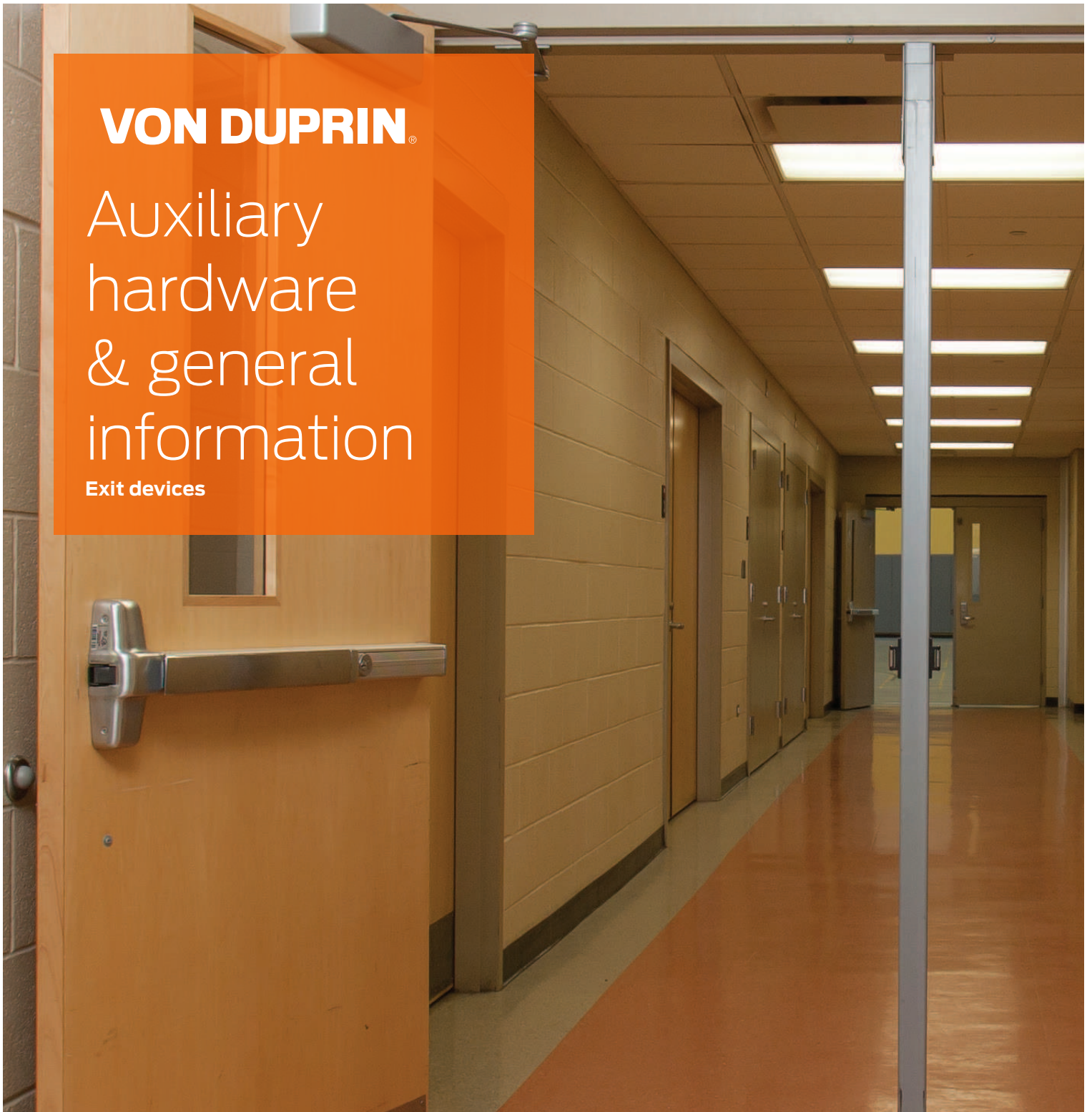

Introduction

Since pioneering the first exit device in 1908, Von Duprin life safety products have provided unparalleled quality, performance and flexibility for schools, hospitals, stadiums and public buildings.

From innovative exit devices to electronic access control solutions and accessories, Von Duprin never compromises when lives are at stake.

Von Duprin exit devices meet or exceed domestic and international quality standards. All devices are UL listed for panic or fire hardware and are ANSI certified. Many models are built to resist hurricane conditions.

VON DUPRIN
Administrative offices
2720 Tobey Dr.
Indianapolis, IN 46219

Customer service
877-671-7011
800-999-0328 - Fax

Technical support
877-671-7011

Table of contents

ANSI Functions for exit hardware	5
Cover plates / Dogging keys	8-9
Cylinders	10
Glass bead kits	10
Handing chart	5
Mullions	12-13
Sex bolt	6
Vertical rod/Latch guard	10
Two point latch	11
Weather stripping	14

Symbols

 Indicates fire rated application

About Von Duprin

The disastrous Iroquois Theater fire in Chicago happened in 1903. Carl Prinzler, Manager of the Vonnegut Hardware Company Builders Hardware Department, was scheduled to be at the matinee, featuring Eddie Foy, but other matters prevailed and he was spared. Five hundred ninety people died, mainly because the theater doors opened inward.

Prinzler spent the next five years working with Henry Dupont, an architectural engineer, developing hardware to preclude a similar horror. Together they fashioned a lever that kept doors locked on the outside, yet unlocked from the inside. The pivotal element was the crossbar which opened the door outward once any part of the body touched it.

That was 1908. Since that time, Von Duprin has been instrumental in transforming fire and panic exit hardware into sleek, attractive products available in a wide range of styles, functions and finishes.

Thorough and continuous research by Von Duprin has resulted in a parade of improvements and enhancements that has earned it the reputation of being the "R & D Department for the entire industry."

- Von Duprin was first to use drop forgings.
- Von Duprin was first with a special threshold, the Latch-Track.
- Von Duprin developed the first reversible exit device, the 88 rim type device.
- Von Duprin introduced the first extruded aluminum mullion.
- Von Duprin was first to market a concealed vertical rod device for metal doors.
- Von Duprin was first to market a concealed vertical rod device for wood doors.
- Von Duprin was the first to have a line of narrow stile devices, the type NC.
- Von Duprin produced the first stainless steel line of devices, the type 66 series.
- Von Duprin was the first with a line of pushpad devices, the type 33 series.
- Von Duprin was the first with electric locking and unlocking, the type E device.
- Von Duprin was the first with self contained delayed exit, CHEXIT®

In addition, during the 1920's Von Duprin developed the type Q

device, which was approved by Underwriter's Laboratories, Inc., for three hour fire rated doors. Subsequently, Von Duprin has successfully tested the industry's most complete line of Fire Exit Hardware.

Along with these impressive developments, we are proud of our record of manufacturing quality products that give years and years of solid dependable service with minimum maintenance. While it is satisfying to reflect on these accomplishments, it is even more significant that Von Duprin has the purpose and the spirit to continue to lead the fire and life safety industry in providing "THE SAFE WAY OUT!"

How the name "VON DUPRIN" originated: VON (Vonnegut Hardware Company), DU (DuPont), the architectural engineer, who helped PRIN (Prinzler) develop the first Von Duprin exit device.

UL listings

Most Von Duprin exit devices are UL Listed for Panic Hardware or Fire Exit Hardware, and are tested in accordance to ANSI A156.3, 2008, Grade 1.

UL listed panic hardware

To be UL listed a device must pass rigorous tests to prove it is mechanically sound and reliable. One test puts the device through 100,000 controlled open and close cycles. In another, the activating mechanism is required to operate with 50 pounds of pressure or less when 250 pounds of pressure is applied to the door in the direction of the swing.

Fire exit hardware

To carry the UL Label for Fire Exit Hardware, a device first must meet the Accident Hazard requirements. Secondly, the device must pass the burn test to prove that it can hold fire doors closed for up to a three hour period in temperatures over 1900°F. Immediately after burning, a fire hose with approximately 45 lbs. PSI pressure at the nozzle puts stress on the opening as a final test of the hardware's ability to hold the doors closed.

ANSI Functions for exit hardware

A variety of ANSI functions are offered with each series. Each device section of the catalog contains a chart showing the ANSI types and functions available in the series.

Function	
01	Exit only, no trim
02	Entrance by trim when actuating bar is locked down.
03	Entrance by trim when latch bolt is retracted by key. Key removable only when locked.
04	Entrance by trim when latch bolt is retracted by key or set in a retracted position by key.
05	Entrance by thumbpiece. Key locks or unlocks thumbpiece.
06	Entrance by thumbpiece only when released by key. Key removable only when locked.
07	Entrance by thumbpiece. Inside key locks or unlocks thumbpiece. Outside key retracts latch.
08	Entrance by knob or lever. Key locks or unlocks knob.
09	Entrance by knob or lever only when released by key. Key removable only when locked.
10	Entrance by knob or lever. Inside key locks or unlocks knob. Outside key retracts latch.
11	Entrance by control turn piece. Key locks or unlocks control.
12	Entrance by control turn piece only released by turning key. Key removable only when locked.

Door handing

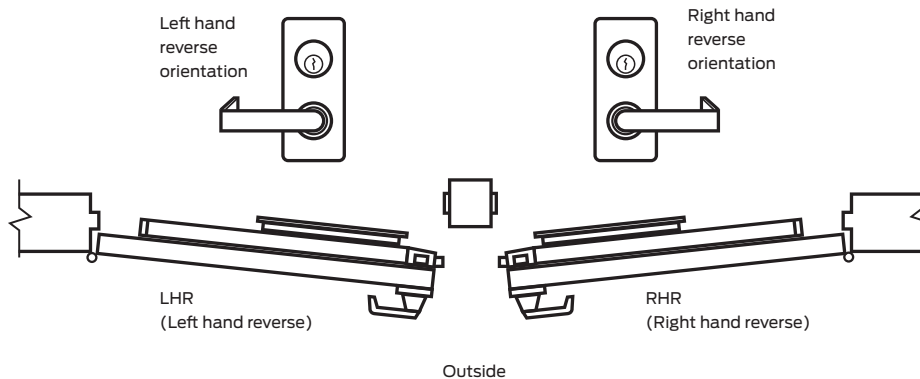

Sex bolts

Sex Bolts when ordered with devices may be furnished with screw lengths different than shown in Column B. On page 7, Column B indicates popular sizes. Sex Bolts ordered separately are not furnished with screws. If screws are required refer to chart on page 7 and order screws by description as a separate item. Other screw lengths may be used based on minimum and maximum allowable thread engagement, shown in column "C." Quantity required — refer to device section, quantities differ depending on outside trim.

425 sex bolts are required for 22/88/98/99 series fire rated devices when used on wood door applications. When wood doors are specified for these devices, sex bolts will be added to the device application unless SLM blocking package is specified.

825 sex bolts are required with 98-F/99-F rim devices on wood door applications using EO, NL, TP, K and L outside trims. Two 825 sex bolts will be added to the device application unless SLM blocking package is specified.

To order, specify

1. Model number
2. Quantity (2 per package)
3. Finish
4. Door thickness other than 1³/₄" (44mm).

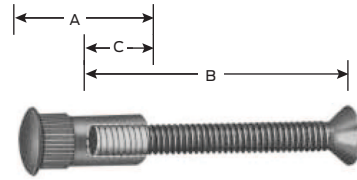

325,425,625A & 625B

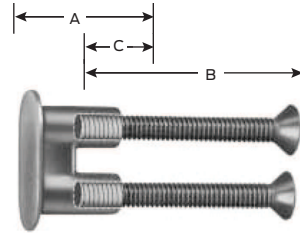

525



Refer to page 7 for A, B and C lengths

Vertical rods

Rim, mortise and concealed vertical rod

Device type	Door thickness	Center case				Hinge case			
		Sex Bolt			C Thread engagement min. - max.	Sex bolt			C Thread engagement min. - max.
		No.	A	B Screw		No.	A	B Screw	
22	1 3/4" (44mm)	425	1 9/16"	10-24 x 1" PPHMS	9/32" - 5/8"	425	1 9/16"	10-24 x 3/4" PPHMS	9/32" - 5/8"
	2 1/4" (57mm)	425	1 9/16"	10-24 x 1 1/2" PPHMS	9/32" - 5/8"	425	1 9/16"	10-24 x 1 1/4" PPHMS	9/32" - 5/8"
33A, 3347A, 3347A-F 35A, 3547A, 3547A-F	1 3/4" (44mm)	325	1 9/32"	1/4"-20 x 1" FPHMS	3/8" - 11/16"	425	1 9/16"	10-24 x 3/4" PPHMS	9/32" - 5/8"
	2 1/4" (57mm)	325	1 9/32"	1/4"-20 x 1 1/2" FPHMS	3/8" - 11/16"	425	1 9/16"	10-24 x 1 1/4" PPHMS	9/32" - 5/8"
55	1 3/4" (44mm)	625A	2 5/16"	12-24 x 3/4" OPHMS	11/32" - 13/16"	625A	2 5/16"	12-24 x 3/4" OPHMS	9/32" - 13/16"
	2 1/4" (57mm)	625B	2 13/16"	12-24 x 3/4" OPHMS	11/32" - 1"	625B	2 13/16"	12-24 x 1 1/4" OPHMS	11/32" - 1"
5575, 5575-F 5547, 5547F	1 3/4" (44mm)	—	—	—	—	625A	2 5/16"	12-24 x 3/4" OPHMS	11/32" - 13/16"
	2 1/4" (57mm)	—	—	—	—	625B	2 13/16"	12-24 x 1 1/4" OPHMS	11/32" - 1"
88, 88-F, 8875, 8875-F	1 3/4" (44mm)	425	1 9/16"	10-24 x 1 1/2" OPHMS	9/32" - 5/8"	425	1 9/16"	10-24 x 1 1/2" OPHMS	9/32" - 5/8"
	2 1/4" (57mm)	425	1 9/16"	10-24 x 2" OPHMS	9/32" - 5/8"	425	1 9/16"	10-24 x 2" OPHMS	9/32" - 5/8"
8847-F	1 3/4" (44mm)	—	—	—	—	425	1 9/16"	10-24 x 1 1/2" OPHMS	9/32" - 5/8"
	2 1/4" (57mm)	—	—	—	—	425	1 9/16"	10-24 x 2" OPHMS	9/32" - 5/8"
98, 9875, 9875-F, 9847, 9847-F, 99, 9975, 9975-F, 9947, 9947-F	1 3/4" (44mm)	425	1 9/16"	10-24 x 1" PPHMS	9/32" - 5/8"	425	1 9/16"	10-24 x 1" PPHMS	9/32" - 5/8"
	2 1/4" (57mm)	425	1 9/16"	10-24 x 1 1/2" PPHMS	9/32" - 5/8"	425	1 9/16"	10-24 x 1 1/2" PPHMS	9/32" - 5/8"
98-F, 99-F*	1 3/4" (44mm)	425	1 9/16"	10-24 x 1" PPHMS	9/32" - 5/8"	425	1 9/16"	10-24 x 3/4" PPHMS	9/32" - 5/8"
		825A*	1 13/16"	10-24 x 3/4" PPHMS	9/32" - 5/8"				
	2 1/4" (57mm)	425	1 9/16"	10-24 x 1 1/2" PPHMS	9/32" - 5/8"	425	1 9/16"	10-24 x 1 1/4" PPHMS	9/32" - 5/8"
		825B*	1 13/16"	10-24 x 3/4" PPHMS	9/32" - 5/8"				

Surface vertical rod

Device type	Door thickness	Center case				Hinge case				Top & bottom latch case			
		Sex bolt			C Thread engagement min. - max.	Sex bolt			C Thread engagement min. - max.	Sex bolt			C Thread engagement min. - max.
		No.	A	B Screw		No.	A	B Screw		No.	A	B Screw	
2227, 2227-F	1 3/4" (44mm)	425	1 9/16"	10-24 x 1" PPHMS	9/32" - 5/8"	425	1 9/16"	10-24 x 3/4" PPHMS	9/32" - 5/8"	325	1 9/32"	1/4"-20 x 3/4" UFPHMS	3/8" - 1/8"
	2 1/4" (57mm)	425	1 9/16"	10-24 x 1 1/2" PPHMS	9/32" - 5/8"	425	1 9/16"	10-24 x 1 1/4" PPHMS	9/32" - 5/8"	325	1 9/32"	1/4"-20 x 1 1/4" UFPHMS	3/8" - 1/8"
3327A 3527A	1 3/4" (44mm)	325	1 9/32"	1/4"-20 x 1" FPHMS	3/8" - 11/16"	425	1 9/16"	10-24 x 3/4" PPHMS	9/32" - 5/8"	325	1 9/32"	1/4"-20 x 3/4" UFPHMS	3/8" - 1/8"
	2 1/4" (57mm)	325	1 9/32"	1/4"-20 x 1 1/2" FPHMS	3/8" - 11/16"	425	1 9/16"	10-24 x 1 1/4" PPHMS	9/32" - 5/8"	325	1 9/32"	1/4"-20 x 1 1/4" UFPHMS	3/8" - 1/8"
8827, 8827-F	1 3/4" (44mm)	425	1 9/16"	10-24 x 1 1/2" OPHMS	9/32" - 5/8"	425	1 9/16"	10-24 x 1 1/2" OPHMS	9/32" - 5/8"	425	1 9/32"	10-24 x 3/4" PPHMS	9/32" - 5/8"
	2 1/4" (57mm)	425	1 9/16"	10-24 x 2" OPHMS	9/32" - 5/8"	425	1 9/16"	10-24 x 2" OPHMS	9/32" - 5/8"	425	1 9/32"	10-24 x 1 1/4" PPHMS	9/32" - 5/8"
9827, 9827-F 9857 9857-F	1 3/4" (44mm)	425	1 9/16"	10-24 x 1" PPHMS	9/32" - 5/8"	425	1 9/16"	10-24 x 3/4" PPHMS	9/32" - 5/8"	325	1 9/32"	1/4"-20 x 3/4" UFPHMS	3/8" - 1/8"
9927, 9927-F 9897 9957-F	2 1/4" (57mm)	425	1 9/16"	10-24 x 1 1/2" PPHMS	9/32" - 5/8"	425	1 9/16"	10-24 x 1 1/4" PPHMS	9/32" - 5/8"	325	1 9/32"	1/4"-20 x 1 1/4" UFPHMS	3/8" - 1/8"

FPHMS — Flat Phillips head machine screw
OPHMS — Oval Phillips head machine screw
PPHMS — Pan Phillips head machine screw
UFPHMS — Undercut flat Phillips head machine screw

Cover plates

229 Kit

(For 22 Rim device)

Kit contains inside and outside plates for hinge stile cutouts, an inside plate for the the lock stile, and necessary screws. Plates are designed to cover cutouts required by most existing exit device installations. Specify finish.

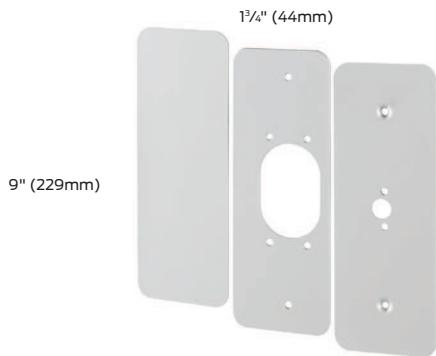

887 Kit

(For 88 Rim/8827 Devices)

For use with rim/vertical device combinations on pairs of doors with ANSI cut-out. The 88 rim device backset is increased and exposes the 161 cutout when used with an 8827. Specify finish

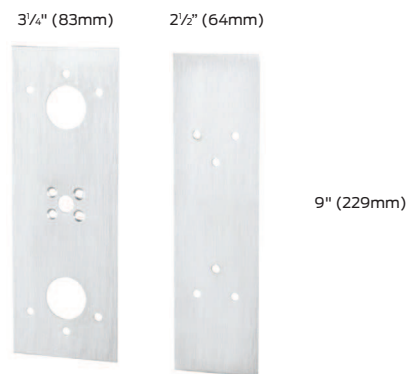

882 Kit

(For 88 Rim device)

For use to cover mortise lock or discontinued device cut-outs. Specify finish.

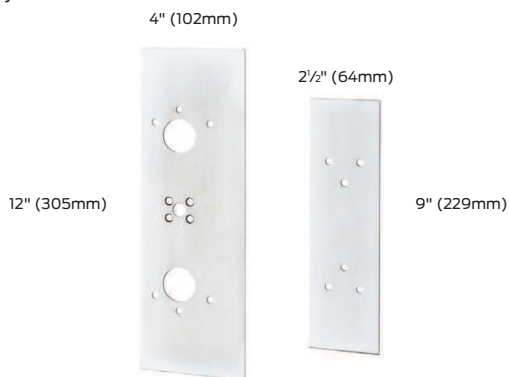

589 Kit

(For 5575 Device)

Kit contains plates for the lock stile and hinge side of the device, and necessary screws. Plates are designed to mount to device on wood door applications. The mortise lock cut-out interferes with device mounting. Specify finish and door width other than 1 3/4 inches (44mm).



997 Kit

(For 98/99 Rim Device)

Kit contains inside and outside plates for hinge stile cutouts, an inside plate for lock stile, and necessary screws. Plates are designed to cover cutouts required by most existing exit device installations. Specify finish.

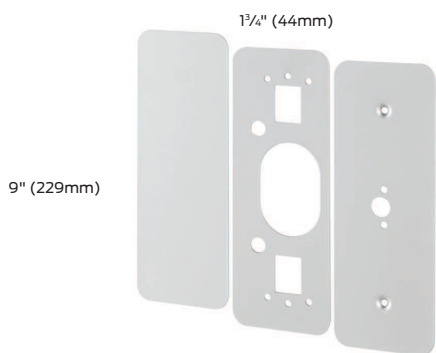

888 Kit

(For 8875 or 8827 Devices)

For use on doors with ANSI 161 cutouts. Device center case will not cover stock cutout. Specify finish.

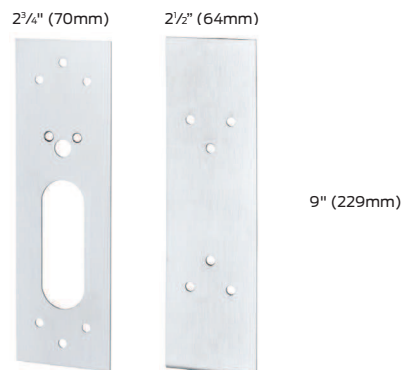

Cover plates

889 Kit

(For 373L Control)

Required when 373L controls are used with sex bolts. Four studs on cover plate allow through bolting to the device center case
Note: Sex bolts must be used on wood or composite fire doors. Specify device type R, M, or V and finish.

998 Kit

(For 994L Trim)

For use with 994 lever trim to cover existing 992 lever trim cut-out. Specify finish

#10 WDA Kit

(For 370 Series controls)

For wood door applications, used to cover up door preparations for control, also prevents the control from boring into the wood door. Finished to match control.

33A WDA Kit

(For 360 Series controls)

For wood door applications to cover up door preparations for control, also prevents the control from boring into the wood door. Finished to match control.

Dog keys

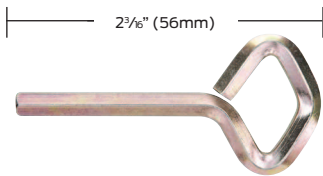

222 Dog key (old style)

$\frac{5}{32}$ " (4mm) hex

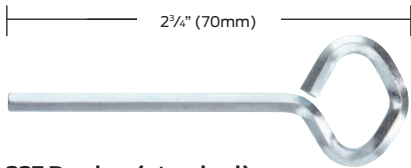

227 Dog key (standard)

$\frac{7}{32}$ " (4mm) hex

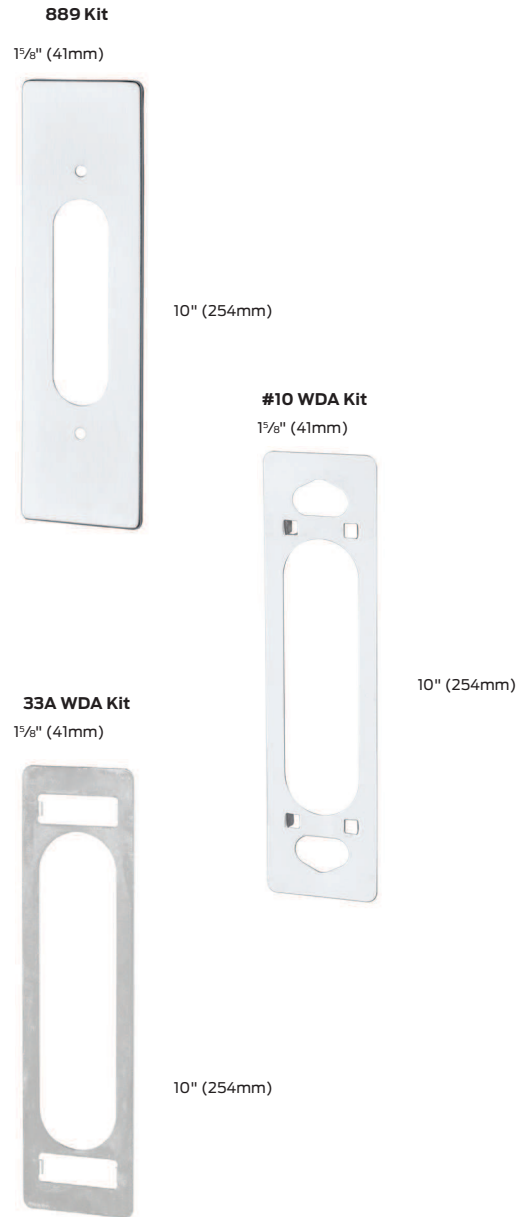

Cylinders

Cylinders

Cylinders are not furnished with device or trim and must be specified when ordering. Refer to exit device catalogs for cylinder requirements.



Mortise — 3215 (Schlage 20-001, B502-191 cam)

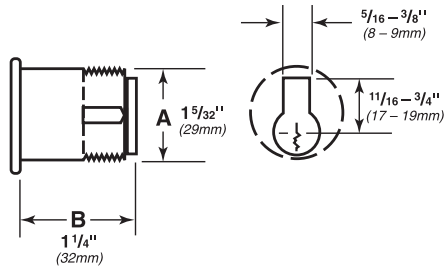

Rim — 3216 (Schlage 20-022 cam)

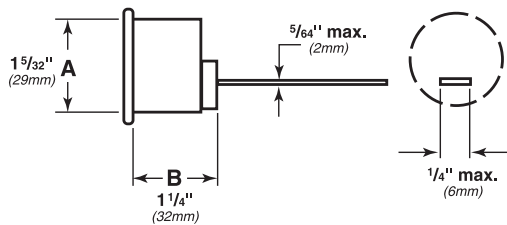

3218 Dummy



Glass bead kit — GBK

Glass bead conversion kits are used on doors with glass beads. Each kit consists of 1 1/4" (6mm) shim sets. GBK for Surface Vertical Rod ships with 1 1/8" (3mm) shims for rod guides. Shims are not required for top and bottom latches

To order, specify:

1. Device Model. Example: 99GBK
2. Device type (rim, mortise, surface vertical rod, concealed vertical rod)
3. Wood door, when used with concealed vertical rod
4. Specify if using with 499F Strike
5. Finish

RG-27 Vertical rod and latch guard



RG-27 Series vertical rod and latch guards protect the bottom rods of exit devices from the damaging impacts of carts or gurneys passing through doors. (If bottom rods become damaged, the exit device will not function as intended and can jeopardize the ability to exit safely during an emergency.)

In addition to protecting the vertical rod, the guard provides a smooth, unobstructed surface so the door can be pushed open easily with the bumpers of a wheelchair. The latch guard portion is 10" high. The standard latch guard features a 45° ramp. The extended latch guard offers a continuous ramp in 3' or 4' widths.

All stainless steel construction in US32D finish. Latch guards can cover latches as large as 1 1/4"W x 10"H x 1 7/8" projection.

Rod guard

Latch guard



Extended latch guard

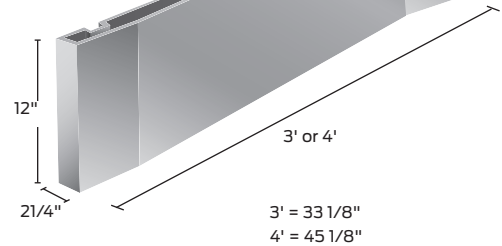

Models

- RGO** Rod guard only (Projection 1 3/16")
- RG-27** Rod and latch guard
- RG-27-3** 3' (914 mm) Rod guard and extended latch guard
- RG-27-4** 4' (1219 mm) Rod guard and extended latch guard
- LGO** Latch guard only
- LGO-3** 3' (914 mm) Extended latch guard only
- LGO-4** 4' (1219 mm) Extended latch guard only

Note: Not for use on wood fire doors, except with SLM (special laminate material) blocking.

To order, specify:

1. Model number.
2. Handing (except on RGO).
3. Door material if other than Hollow Metal.
4. Optional sex bolt mounting available.

237 Two point latch



Series 237 Two point latch

Series 237 Two point latch assembly is ideal for spaces where occupancy does not require panic or fire exit hardware. This product is a perfect solution for many applications in schools, health care facilities, offices, and government facilities – regardless if the doors are inswing or outswing. It can be used on the inactive leaf of a pair of doors with a lockset or both leaves of a pair. It features a top soffit latch and ratchet release for long service life and dependability. Locking handles in many different configurations provide versatility to meet different customer needs.

Engineered to withstand severe weather conditions, the 237 series is also ideal for community shelters and safe rooms in accordance with FEMA 320 and 361 guidelines.

Specifications compliance

- I. UL listings:
 - Two- and Three-point Locks and Latches (for use on Fire Doors) – UL 10 C
 - Rating: 3HR Pairs (Double Egress)
 - 90 Min. Pairs (Swing Same Direction)
 - Door Size: 8'0" X 8'0" Pairs (Hollow Metal Only)
- II. Windstorm ratings:
 - A. UL – FEMA 320 and 361 certified:
 - i. 4'0" X 8'0" Single Doors (Non-fire-rated) Hollow Metal
 - ii. 8'0" X 8'0" Pairs Hollow Metal
 - B. UL-ANSI/ICC 500 certified for F5 Tornado applications

These products are listed with Steelcraft PW14 Series door for Tornado Listings

Top rod assembly



Bottom rod assembly



Furnished standard with one lever control assembly with mounting plate for the push side. This lever operation is always unlocked (L-BE). A second control lever can be ordered separately for the pull side, either model 378L-BE (always unlocked) or model 378L (with cylinder locking). Cylinders not included.

Lever operation meets all ADA requirements.

To order, specify:

1. Model number 237L-BE.
2. Optional second control, 378L or 378L-BE.
3. Handing (see charts below).
4. Finish.

Optional lever styles are available



Handing – how to order

Outswing door application

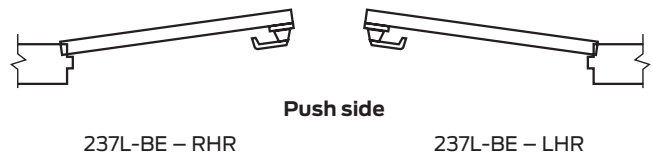

NOTE: For inswing door applications that require locking on the push side, consult factory. Outswing door will be assumed if not specified.

Mullions

Mullions

Removable steel mullions Mullions provide single door performance in double door openings with rim devices. Mullions are easily removed by loosening bottom set screw and removing top fitting cover. The top mullion fitting is attached to the frame and is concealed by the fitting cover.

Steel mullions are 2" (51mm) wide and 3" (76mm) deep, with a wall thickness of $\frac{1}{8}$ " (3mm).

Mullions are shipped with mounting screws and prepared for strikes. Strikes are not included except where indicated.

Steel mullions are available in SP28 and SP313 finishes. Consult factory for other powder coat finish options.

KR – Keyed removable steel mullions makes removal faster and easier by a single operation of the mortise cylinder. Once mullion is removed, large equipment or furniture can freely pass through the opening. The unit will self lock when re-installed, without use of the cylinder key. Uses a $1\frac{1}{4}$ " mortise cylinder with a straight cam (Schlage cam reference B502-191). Cylinders are sold separately. Prefix mullion model with "KR".

Removeable aluminum mullions are $1\frac{1}{16}$ " (27mm) wide on face closest to the door and $2\frac{3}{8}$ " (60mm) at the widest point. The depth is $3\frac{1}{8}$ " (79mm) with a wall thickness of $\frac{1}{8}$ " (3mm).

Aluminum mullions are available in US4, US10, US28, 313 and 315 finishes. Consult factory for other powder coat finish options.

Stock Hollow Metal Applications for devices mounted to cover ANSI 161 cutouts are higher than the standard mullion strike location. Consult the factory for special strike preparation or order a blank mullion. See below.

Blank Mullions are furnished without strike preparation. They are used to mount devices at a strike height different from the standard mullion preparation.

To order, specify:

1. For keyed Removable option on steel mullions, prefix model number with "KR"
2. Model number.
3. Height of opening
4. Finish
5. Handing if required.
6. Centerline deviation (refer to device template for standard centerline).
7. Strikes, when required, should be ordered with device.
8. For keyed Removable option on steel mullions, prefix model number with "KR"

Removable mullions

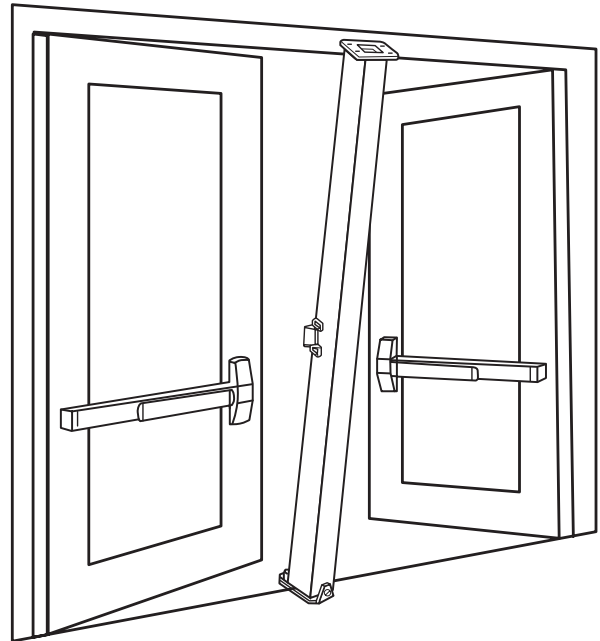

Keyed removable steel mullions

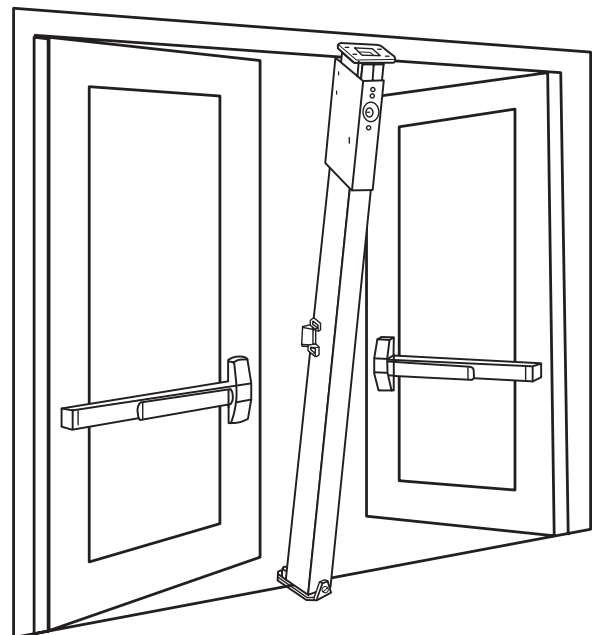

Mullions

Steel mullions

1654 Prepared for two 1606 strikes. **If 1606 strikes are not specified on the order, two per mullion will be added. Additional charges apply.**

4954 Prepared for 264 or 299 strikes. For use with all Von Duprin Panic rim devices. **Note: specify strike choice with device.**

 **9954** Prepared for and must be used with two 268 strikes (88-F device), or two 499F (22-F, 98-F, 99F devices). UL fire labeled mullion for up to 3 hour opening using Von Duprin fire exit rim devices. This mullion is not easily removed due to special fittings.

22-F and 88-F devices are rated up to 8' x 8" (2438mm x 2438mm).

98-F and 99-F devices are rated up to 10'0" (3048mm).

Note: If 268 or 499F strikes are not specified on the order, two per mullion will be added. Additional charges apply.

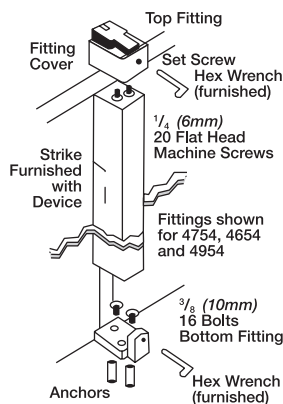
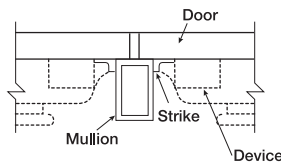

4754 Prepared for two 4263 monitor strikes.

4854 Prepared for one 299 and one 6111 electric strike. Indicate handing for electric strike.

 **9854** Prepared for one 268 or 499F strike and one 6111 electric strike. Indicate handing for electric strike. UL fire labelled mullion for up to 3 hour openings up to 8' x 8' (2438mm x 2438mm) using Von Duprin Fire Exit Rim Devices

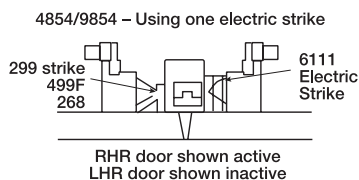

Aluminum mullions

5654 Prepared for two 264 or 299 strikes with weatherstripping. Includes one set of 154 stabilizers.

5754 Prepared and furnished with one 1408 double door strike. Includes one 154 stabilizer set. Note: specify device "less strike".

Sizes for mullions

1654, 4954, 4754, 4854, 5654	9854, 9954
7' 2" (2184mm)	7' 3" (2210mm)
*8' 2" (2489mm)	8' 3" (2475mm)
*10' 2" (3099mm)	10' 3" (3124mm)

KR1654, KR4954, KR4754, KR4854 KR9854**, KR9954***

7' 6" (2286mm)	7' 5" (2261mm)
8' 6" (2591mm)	*8' 5" (2565mm)
10' 6" (3200mm)	*10' 5" (3175mm)

* Only qualifying applications will be provided with UL Label.

** Fire rated same as 9854

*** Fire rated same as 9954

Angle plate is used with narrow transom frames. The plate attaches to the transom extending the surface area needed to mount the mullion. Must be ordered separately. Specify finish.



154 Stabilizer is a two-piece interlocking set. One piece mounts on the mullion with the top mounting hole 5³/₁₆" (148mm) below the centerline of the strike; the other piece mounts on the door. Shims are provided to adjust for misalignment between the door and mullion.

The set maintains integrity between the door and mullion to prevent vandalism and to ensure contact between the device and strike as the doors expand and contract with temperature changes.

Furnished standard on aluminum mullions; optional for steel and all blank steel mullions.



MT54 Storage kit is a set of floor and wall brackets that provide convenient storage of the keyed removable mullion when removed from the opening.

To order, specify

1. Model MT54.
2. Finish SP28, SP313, or SPBLK

Weatherstripping

Weatherstripping

Weatherstripping prevents cold air from blowing between doors and mullion. It also serves as a silencer when the door is closed against the mullion. The silicone treated weatherstrip pile is bonded to a polypropylene backing. A slide-in molding houses the weatherstripping, covers mounting screws of the strike and extends to both the top and bottom of the mullion. Available on aluminum mullions only.

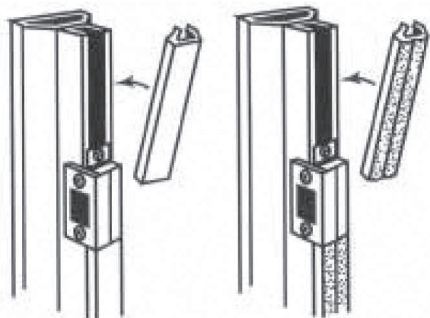

Standard edging

Edging with weatherstripping

Notes

Notes

About Allegion

Allegion (NYSE: ALLE) creates peace of mind by pioneering safety and security. As a \$2 billion provider of security solutions for homes and businesses, Allegion employs more than 8,000 people and sells products in more than 120 countries across the world. Allegion comprises more than 25 global brands, including strategic brands CISA®, Interflex®, LCN®, Schlage® and Von Duprin®.

For more, visit www.allegion.com

aptiQ ■ LCN ■ **SCHLAGE** ■ STEELCRAFT ■ VON DUPRIN