



941079-00

Maintenance Kit

VON DUPRIN®

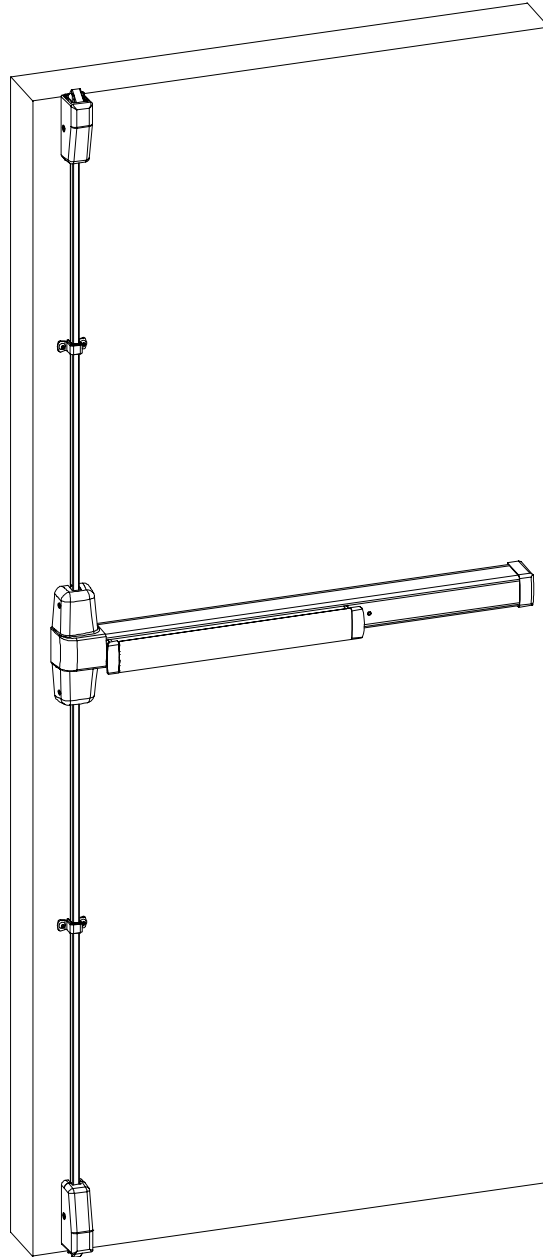

Table of Contents

Description:	Page Number:
Pictorial Index to Parts (immediatey follows "Table of Contents")	PIP-1, PIP-2
1. Center Case Parts	
Insert-98/99 One Piece Cover	1-1
NL Drive Screw-98/99 Device	1-2
Control Link Pin-Touch Bar Device	1-2
Tailpiece Guide	1-3
2. Dogging Assembly Parts	
Hex Dogging Replacement Kit	2-1
Hex Dogging Shaft	2-1
Dogging Adapter Spring	2-2
Dogging Spring	2-3
Cylinder Dog Actuator	2-4
CD Dogging Plug	2-4
3. Mechanism Case Parts	
Mechanism Case Mounting Bracket	3-1
Anti-Rattle Spring-33/35/98/99	3-2
Cover Plate Stop	3-2
Shock Absorber and Holder Assembly	3-3
Pushbar Guide (front)	3-4
Pushbar Guide (rear)	3-5
4. Vertical Rod Parts	
Rod Extension Connector	4-1
Extension Rod DrillTemplate-2227/98/9927	4-1
98/9927 Rod Guide Assembly	4-2
1/8 x 7/16 Roll Pin	4-2
5. Surface Vertical Latch Parts	
299 Strike Shim	5-1
Shim-264/299F/499F Strike	5-1
Bolt Return Spring	5-2
98/9927 Auxiliary Bolt Spring	5-3

Table of Contents (continued)

Description:	Page Number:
6. Concealed Vertical Latch Parts	
Ratchet Lever Spring.....	6-1
#10 External Tooth Lock Washer.....	6-2
Compression Spring-33/3547.....	6-2
7. Mounting Hardware, Screws, and Retaining Rings	
325 Sex Bolt Assembly.....	7-1
425 Sex Bolt Assembly.....	7-1
10-12 x 10-24 x1 PTHCS.....	7-2
10-24 x 3/4 PPHMS.....	7-2
10-24 x 1PPHMS.....	7-3
8-32 x 1/4 UFPHMS.....	7-3
10-24 x 3/4 UFPHMS.....	7-4
1/4-20 x 3/4 UFPHMS.....	7-4
8-18 x 1/2 UFPHSMS.....	7-5
12-24 Mechanism Case Screw.....	7-5
Truarc Retaining Ring T5304-18.....	7-6
10-32 x 1/4 UFPHMSwith Nylock.....	7-7
10-24 x 3/4 FPHMS.....	7-7
8. Trim Parts	
Shear Pin.....	8-1
Cylinder Retaining Cup.....	8-2
992L LiftSpring.....	8-2
Hex Stud-994/996 Trim.....	8-3
1/4-20 Hex AStud.....	8-3
10-24 x 1 3/8PPHMS.....	8-4
Truarc Retaining Ring 5160-42.....	8-4
Wave Spring Washer.....	8-5
1/4-20 x 5/8 SocketSet Screw.....	8-6
Appendix A: Device Lubrication.....	A-1
Appendix B: Latch Lubrication.....	B-1
Index by Part Number.....	IPN-1, IPN-2

Pictorial Index to Parts

The number in each circle below is the page where information on the part is found. Use the "Table of Contents" to find items by part description. Use the "Index by Part Number" in the back of the manual to find items by part number.

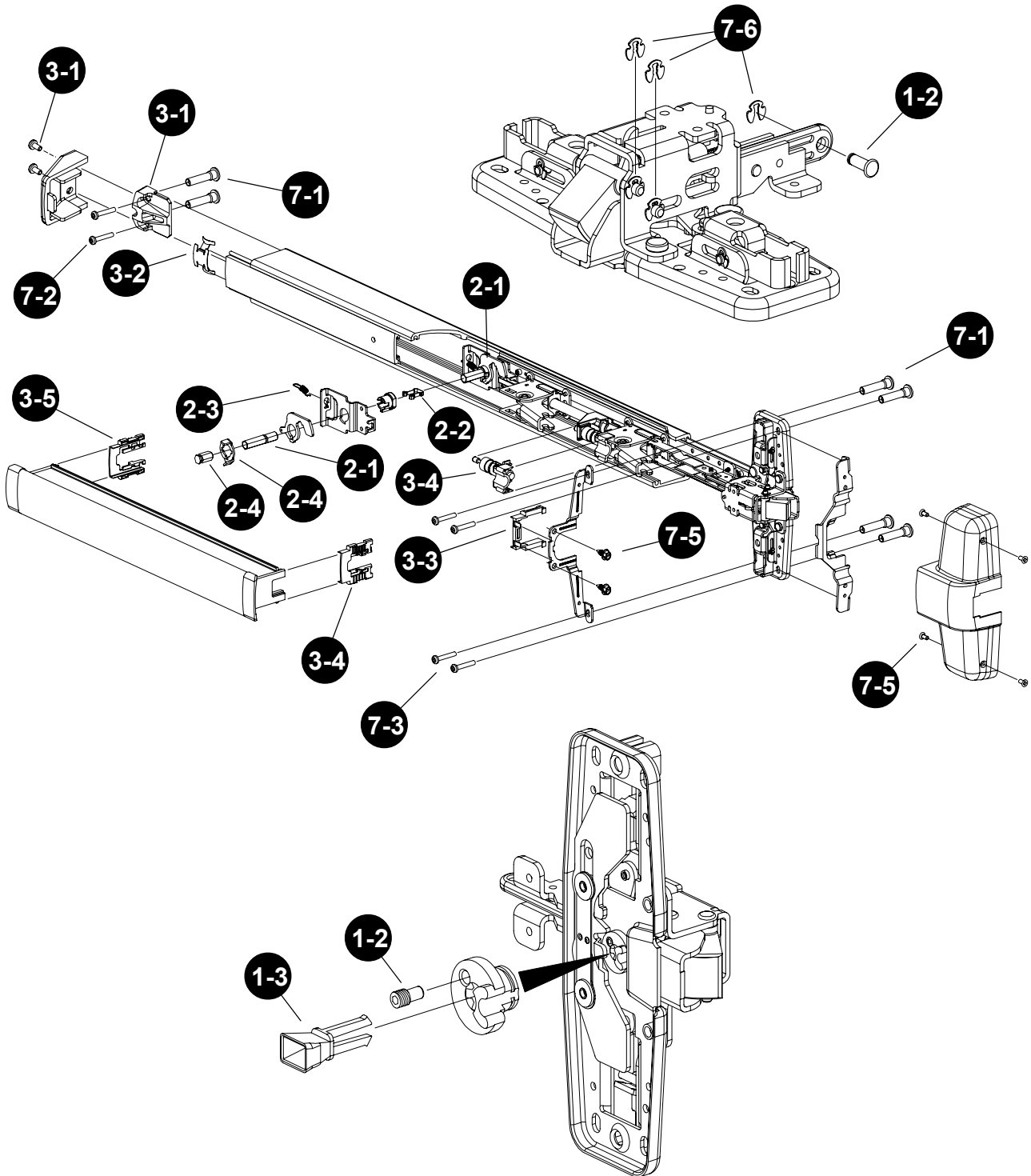

Pictorial Index to Parts (continued)

The number in each circle below is the page where information on the part is found. Use the "Table of Contents" to find items by part description. Use the "Index by Part Number" in the back of the manual to find items by part number.

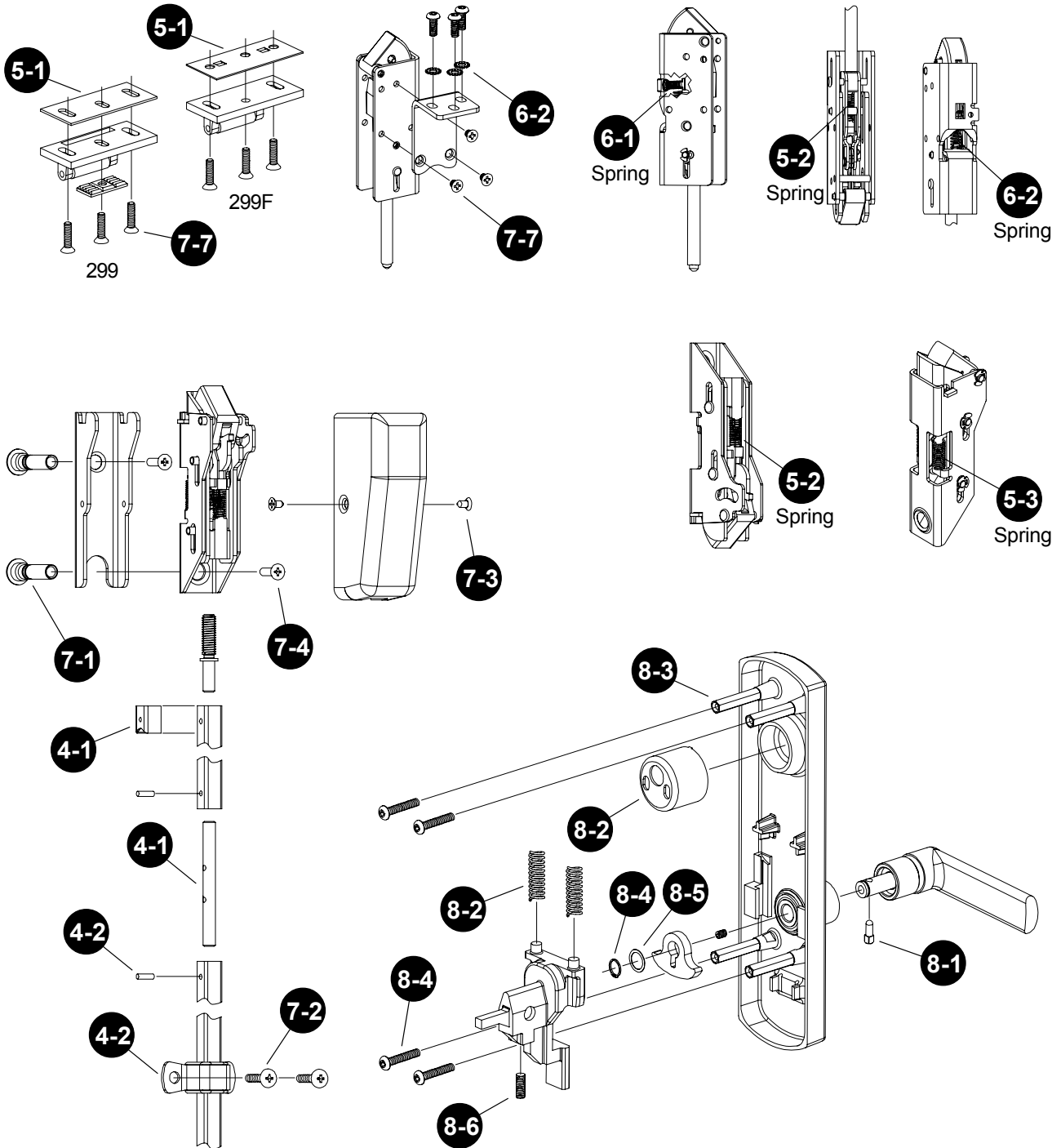

This page is intentionally left blank.

1. Center Case Parts

Part Name: NL Drive Screw-98/99 Device

Kit Location: Bottom drawer #6

Part Number: 970441-89 unit; 090074-00 bulk, 10/pkg.

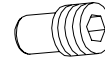

Use: 98/99 and 22 devices; BE, EO, DT, NL, and Rigid applications only

Installation: Use Phillips head screwdriver to turn cam so trim lock slide is in full up position for RHR or LHR application. Install drive screw in cam using 5/64" hex wrench.

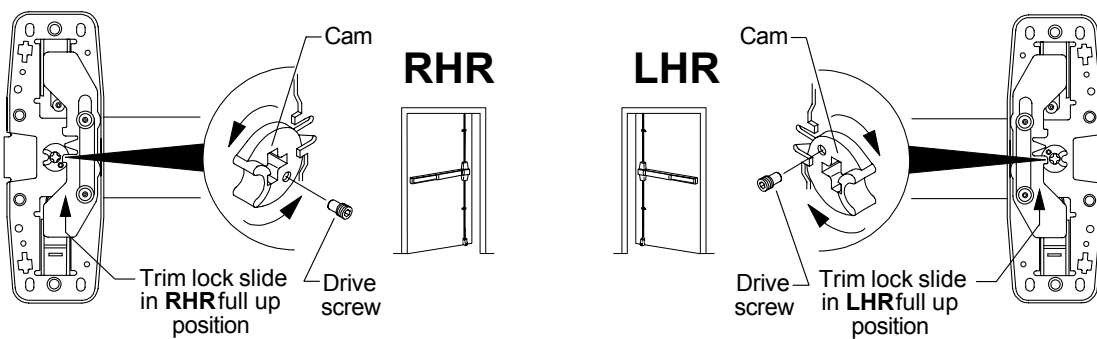

Part Name: Control Link Pin-Touch Bar Device

Kit Location: Top drawer #8

Part Number: 090031-00 bulk, 10/pkg.

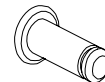

Use: 98/99, 33/35, and 22 devices

Installation: Align holes of main control link and control linkage. Insert control link pin. Secure with Truarc retaining ring T5304-18 (090107-00).

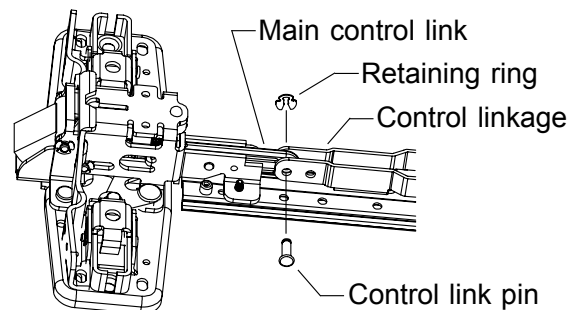

1. Center Case Parts

Part Name: Tailpiece Guide

Kit Location: Top drawer #18

Part Number: 050156-00 bulk, 10/pkg.

Use: 98/99 and 22 device keyed (rim cylinder) trim applications

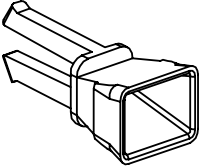

Installation: Snap pronged end of tailpiece guide into cross-slot of master cylinder cam on underside of center case. Guide cylinder tailpiece into funnel portion of tailpiece guide when installing trim.

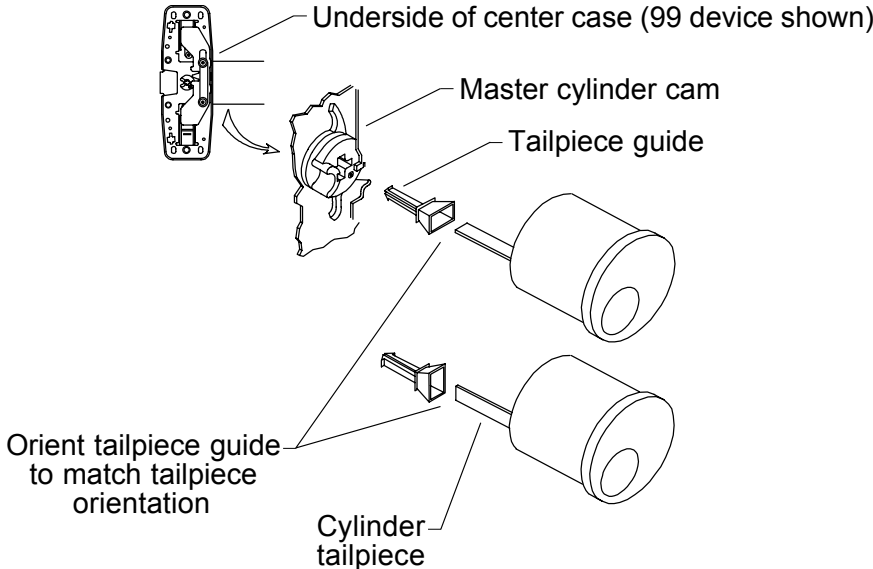

2. Dogging Assembly Parts

Part Name: Hex Dogging Replacement Kit

Kit Location: Top compartment

Part Number: 15-445-00

Use: To replace existing dogging assemblies

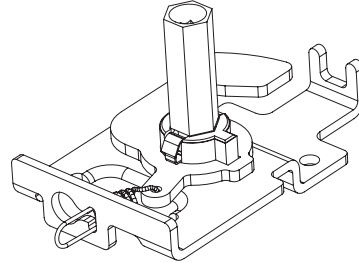

Installation: Remove old dogging assembly, replace with new dogging assembly, and secure with 2 screws.

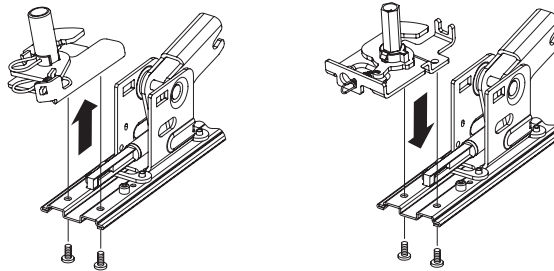

Part Name: Hex Dogging Shaft

Kit Location: Bottom drawer #5

Part Number: 090040-00 bulk, 2/pkg.

Use: 98/99, 33/35, and 22 dogging assemblies made after Aug. 1997



Installation: Insert end of shaft that is closest to groove into dogging adapter. Push down until shaft snaps into place.

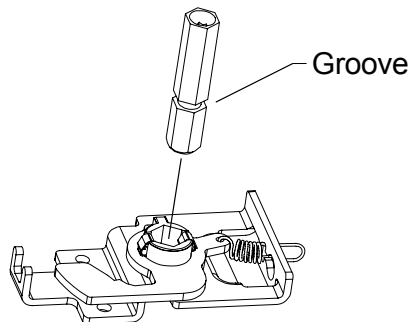

2. Dogging Assembly Parts

Part Name: Dogging Adapter Spring

Kit Location: Bottom drawer #2

Part Number: 090042-00 bulk, 2/pkg.

Use: 98/99, 33/35, and 22 dogging assemblies made after Aug. 1997

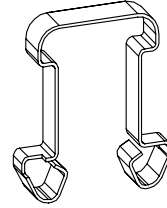

Installation: Pinch legs of spring together and insert into dogging adapter so legs of spring align with grooves in dogging adapter (A). Insert dogging adapter with spring through bottom of dogging plate (B). Snap dogging hook over protruding end of dogging adapter and legs of spring (C). Spring holds dogging adapter, dogging plate, and dogging hook together (D).

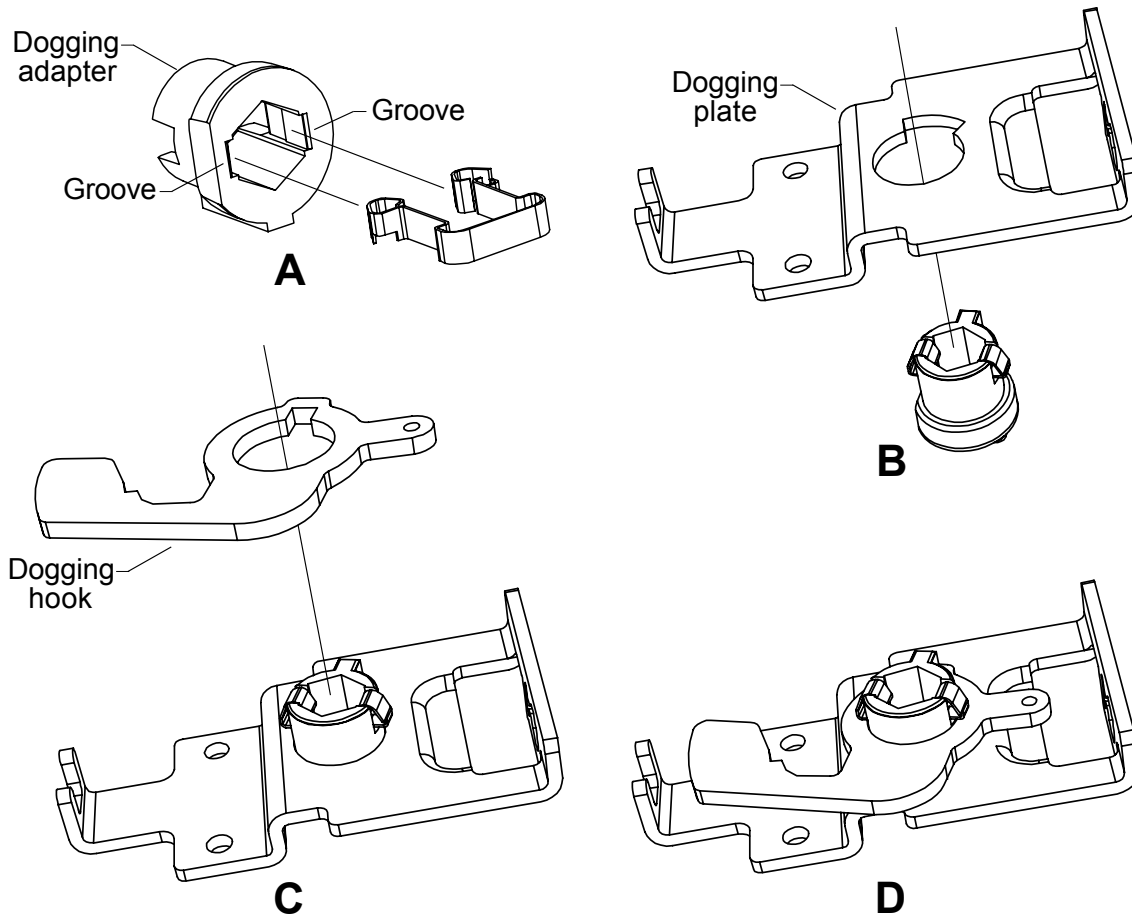

2. Dogging Assembly Parts

Part Name: Dogging Spring

Kit Location: Bottom drawer #3

Part Number: 090041-00 bulk, 2/pkg.

Use: 98/99, 33/35, and 22 dogging assemblies made after Aug. 1997

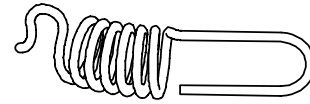

Installation: Hold loop of spring and insert spring through large hole in end of dogging plate (A and B). Hook short end of spring into hole in dogging hook from top of dogging hook (C). Slide loop of spring from large hole (D) into smaller hole in end of dogging plate (E) and align loop vertically (F).

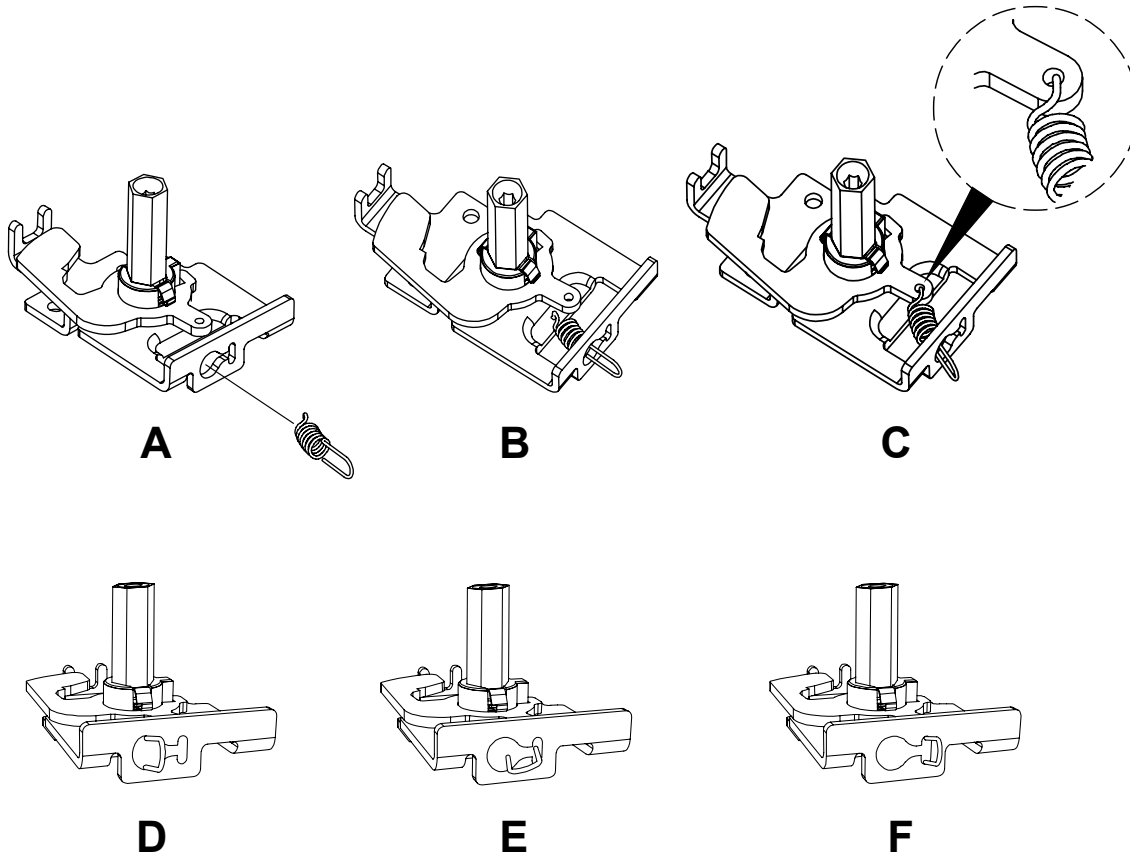

2. Dogging Assembly Parts

Part Name: Cylinder Dog Actuator

Kit Location: Bottom drawer #4

Part Number: 090045-00 bulk, 2/pkg.

Use: 98/99 and 33/35 cylinder dogging assemblies

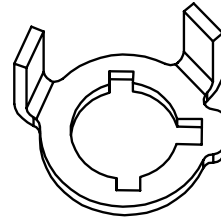

Part Name: CD Dogging Plug

Kit Location: Bottom drawer #11

Part Number: 090046-00 bulk, 2/pkg.

Use: 98/99 and 33/35 cylinder dogging assemblies
made after Sept. 1997

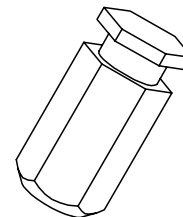

-
- Installation:**
1. Pull hex dogging shaft out of dogging adapter (A).
 2. Snap cylinder dog actuator into place over dogging adapter spring and dogging adapter (B).
 3. Insert CD dogging plug into hex hole in dogging adapter (C) and press until dogging adapter spring snaps into top groove of CD dogging plug (D).

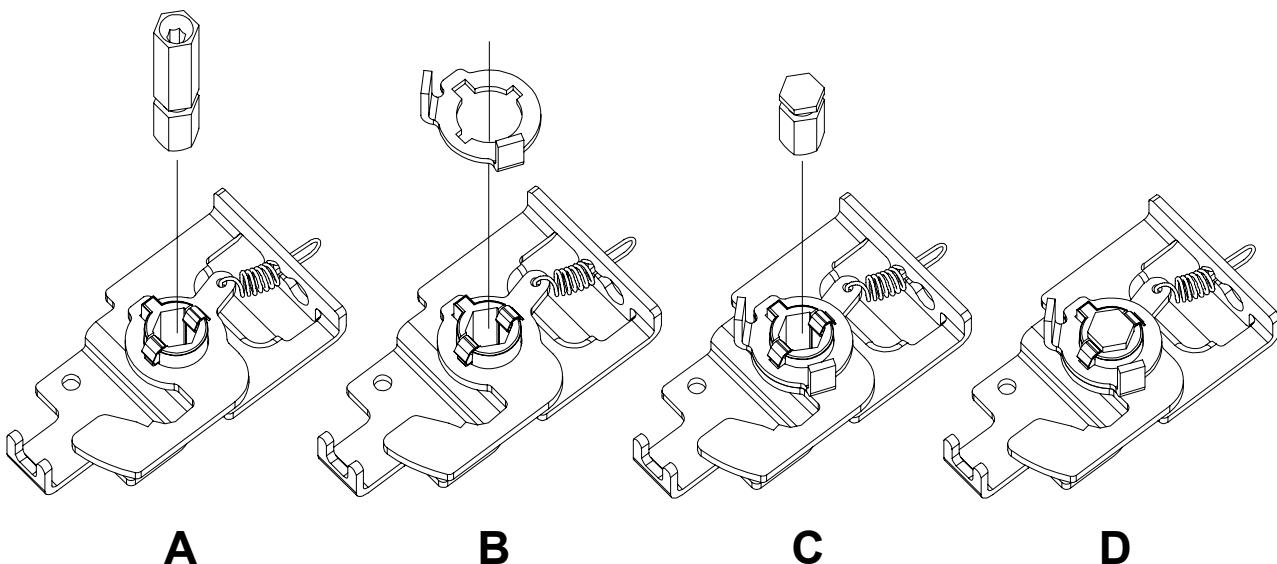

3. Mechanism Case Parts

Part Name: Mechanism Case Mounting Bracket

Kit Location: Top compartment

Part Number: 050524-00 (unit)

Use: 98/99 and 33/35 devices

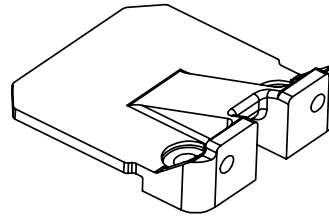

Part Name: End Cap Screw Package

Kit Location: Middle 13

Part Number: 900597-00 bulk, 2/pkg.

Use: 98/99 and 33/35 devices



Installation: Slide bracket into mechanism case making sure that Face A is flush against cover plate. Secure bracket to door. Attach mechanism end cap to bracket (end cap covers bracket).

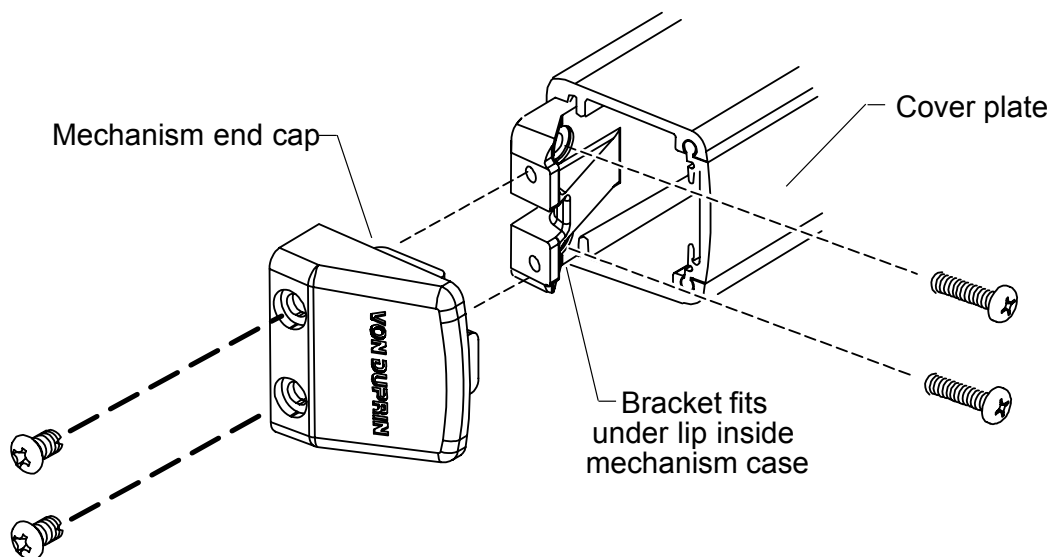

3. Mechanism Case Parts

Part Name: Anti-Rattle Spring-33/35/98/99

Kit Location: Top drawer #11

Part Number: 090036-00 bulk, 10/pkg.

Use: 98/99 and 33/35 devices

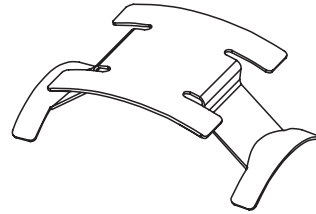

Installation: Without spring, slide cover plate into mechanism case until flush (A and B). Insert front tabs on spring into channel in underside of cover plate (B). Push spring in and make sure rear tabs also engage channel. Continue pushing spring in until vertical tabs on back of spring are flush with end of cover plate (C).

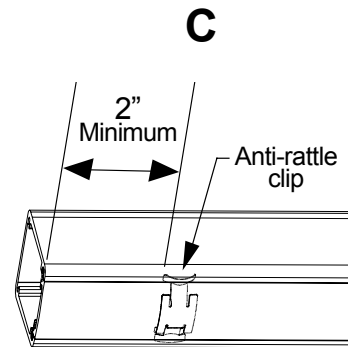
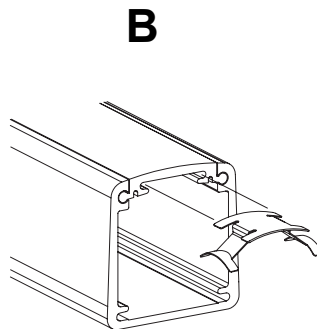
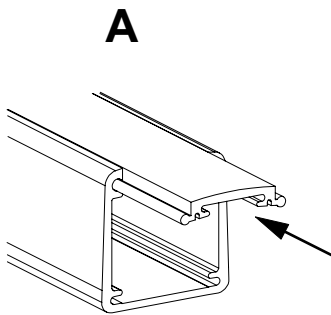

3. Mechanism Case Parts

Part Name: Shock Absorber and Holder Assembly **Kit Location:** Top drawer #17

Part Number: 050491-00 unit

Use: 98/99 and 33/35 devices

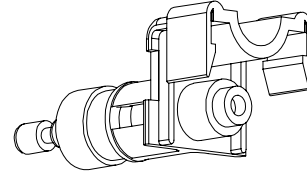

Installation: Place tip of plunger against action rod stop (A). Press in until plunger is fully retracted (B). Rotate shock absorber and holder so tabs slide over top of open guide base (C). Push down so tabs snap into cutouts (C and D).

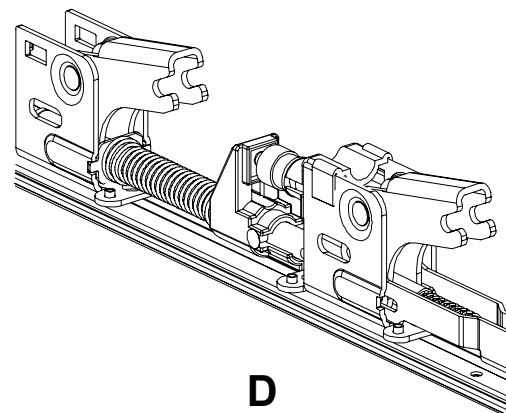
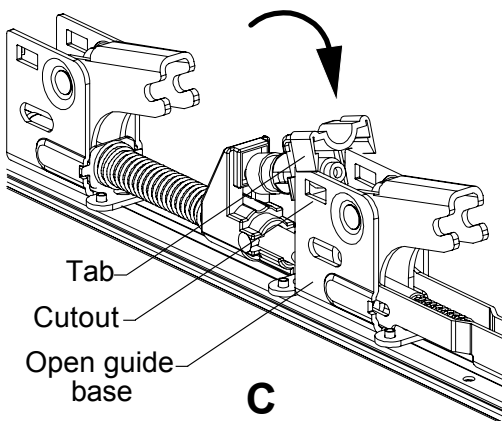
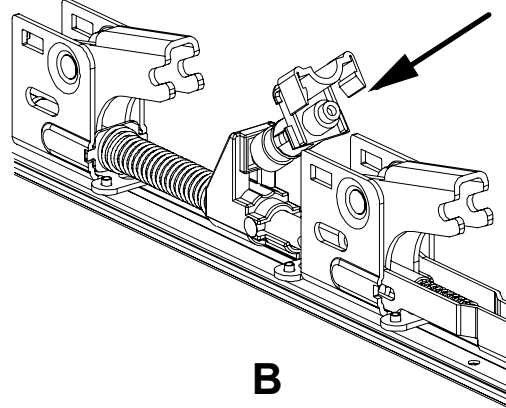
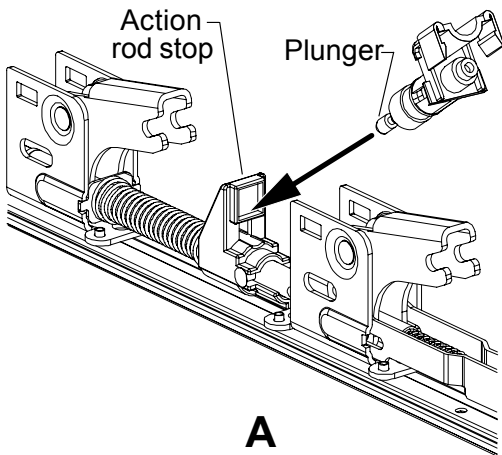

3. Mechanism Case Parts

Part Name: Pushbar Guide (front)

Kit Location: Middle drawer #12

Part Number: 090049-00 bulk, 10/pkg.

Use: 98/99 and 33/35 devices

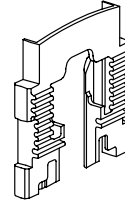

Installation: Remove pushbar from mechanism case. Slide pushbar guide onto front of pushbar. Hold pushbar guide on pushbar and install pushbar on bellcranks. Slide base plate into mechanism case.

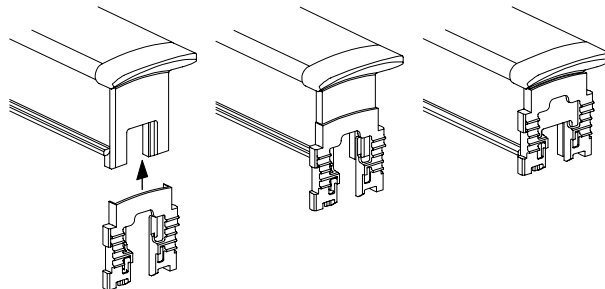

Also replaces older style pushbar guide (part number 971065-00). To replace, slide mechanism case away from center case. Remove cover mounting bracket from center case. Unhook older style pushbar guide from cover mounting bracket and discard. Replace cover mounting bracket. Install new pushbar guide.

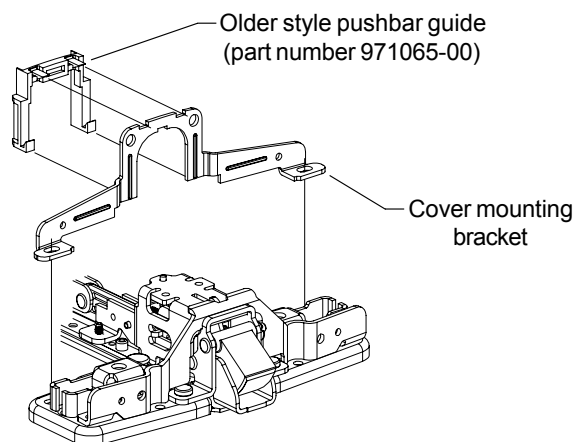

3. Mechanism Case Parts

Part Name: Pushbar Guide (rear)

Kit Location: Middle drawer #12

Part Number: 090049-00 bulk, 10/pkg.

Use: 98/99 and 33/35 devices

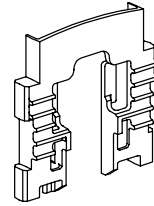

Installation: Remove pushbar from mechanism case. Slide guide onto back of pushbar. Hold guide on pushbar and install pushbar on bellcranks. Slide base plate into mechanism case.

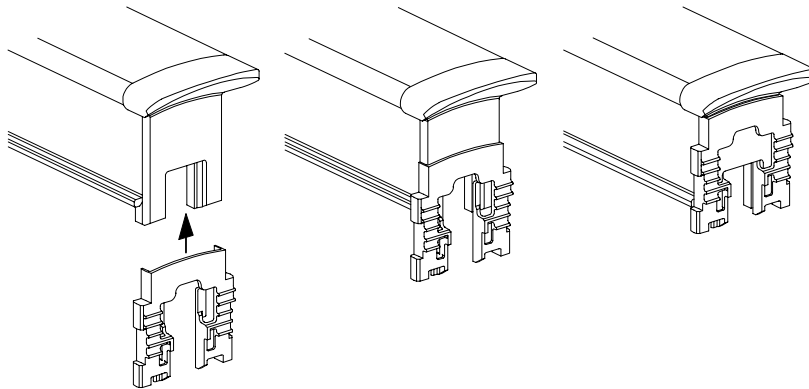

NOTE

This pushbar guide replaces the older style pushbar guide (part number 971066-00) shown below.

4. Vertical Rod Parts

Part Name: Rod Extension Connector

Kit Location: Top drawer #14

Part Number: 090075-00 bulk, 4/pkg.

Use: 98/9927 and 33/3527 devices on doors taller than 7 feet

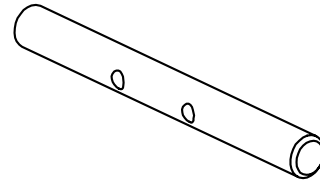

Installation: Drive out roll pin (963935-89) and remove latch case rod connector from latch end of existing rod (A). Insert rod extension connector into latch end of existing rod and either end of extension rod and secure with roll pins (B). Insert latch case rod connector into latch end of extension rod and secure with roll pin (C).

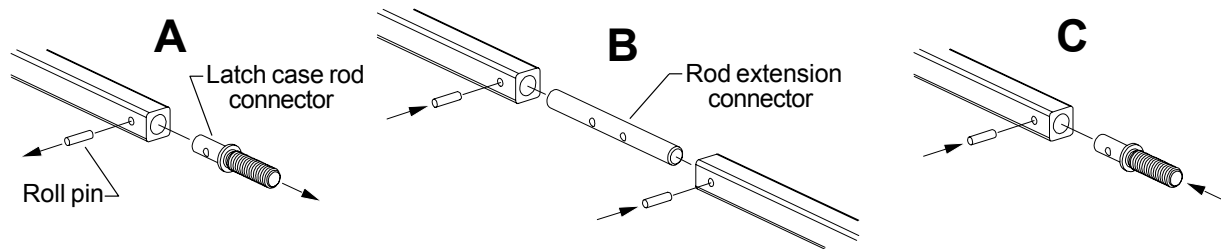

Part Name: Extension Rod Drill Template-2227/98/9927 **Kit Location:** Top drawer #7

Part Number: 969298-89 unit

Use: To locate roll pin hole on 98/9927, 33/3527, and 2227 vertical rods

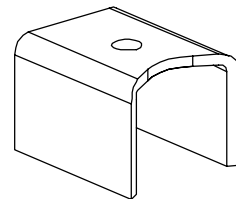

Installation: Slide template on rod until bottom of rod and bottom of template are flush. Drill 1/8" diameter hole through hole in template.



4. Vertical Rod Parts

Part Name: 98/9927 Rod Guide Assembly

Kit Location: Bottom drawer #14

Part Number: 112063-32 unit

Use: 98/9927 and 2227 devices made after 1993

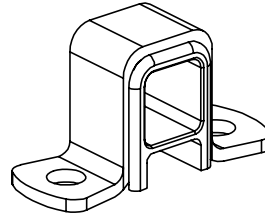

NOTE
112063-32 finish is stainless.
Other finishes available.

Installation: Slide over rod after rods have been adjusted. Place half way between device center case and latch. Secure to door with screws.

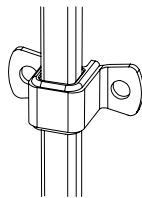

Part Name: 1/8 x 7/16 Roll Pin

Kit Location: Top drawer #10

Part Number: 090054-00 bulk, 10/pkg.

Use: 98/9927 and 33/3527 vertical rods

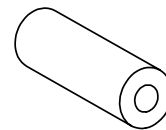

Installation: Line up holes in rod and latch case rod connector (A) or in rod and rod extension connector (B) and drive roll pin through hole.

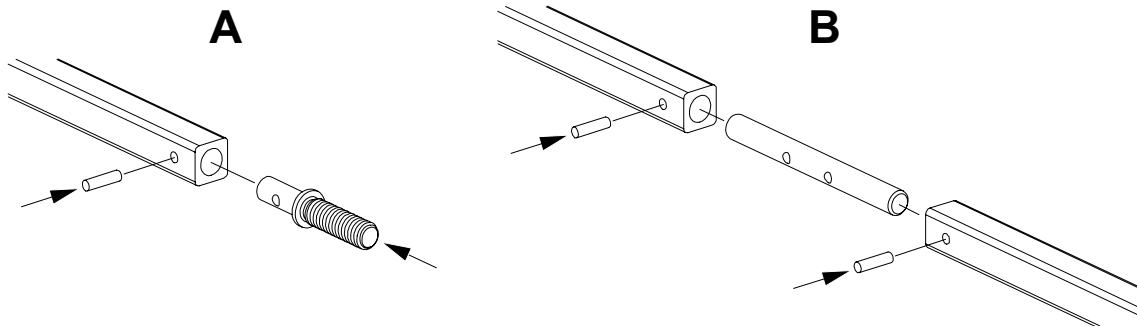

5. Surface Vertical Latch Parts

Part Name: 299 Strike Shim

Kit Location: Top drawer #16

Part Number: 970321-89 unit

Use: 299 strikes to decrease spacing between strike and latch

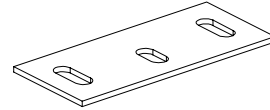

Installation: Position shim as shown. Prepare center hole per chart.

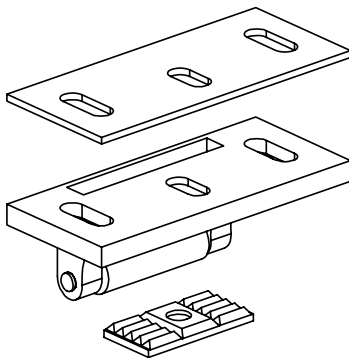

Metal Frame	
Prep:	#25drill and #10-24 tap
Screw:	10-24 x 3/4 FPHMS
Wood Frame	
Prep:	1/8" pilot drill x 1" deep
Screw:	10 x 11/2 FPHWS

Part Name: Shim-264/299F/499F Strike

Kit Location: Bottom drawer #15

Part Number: 945521-89 unit

Use: 264, 299F, and 499F strikes to decrease spacing between strike and latch

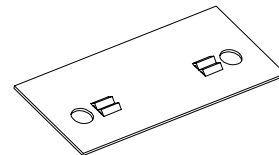

Installation: Position shim with teeth facing strike and closest to strike roller. Mate teeth with notches in bottom of strike. Prepare center hole per chart.

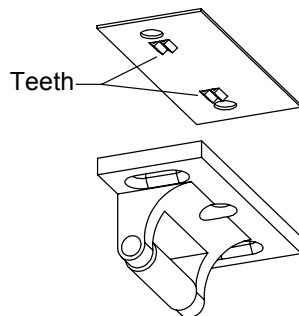

Metal Frame	
Prep:	#25drill and #10-24 tap
Screw:	10-24 x 3/4 FPHMS
Wood Frame	
Prep:	1/8" pilot drill x 1" deep
Screw:	10 x 11/2 FPHWS

5. Surface Vertical Latch Parts

Part Name: Bolt Return Spring

Kit Location: Bottom drawer #9

Part Number: 090065-00 bulk, 10/pkg.

Use: 98/9927/27-F and 2227/27-F top and bottom latches
98/9947/47-F and 33/3547/47-F bottom latches

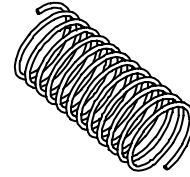

Installation: For 98/9947/47-F and 33/3547/47-F latch, remove Truarc retaining ring, latch pin, and rod connecting screw for accessibility. Replace after installing spring.

98/9947/47-F and 33/3547/47-F Bottom Latch

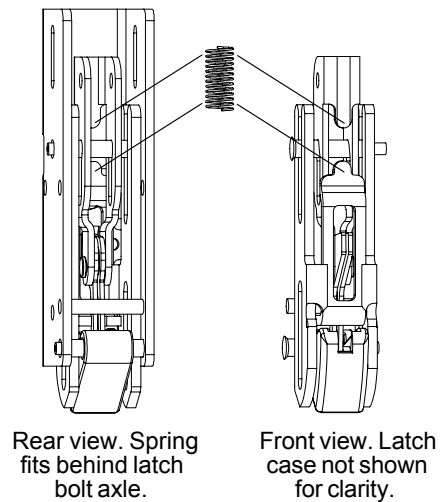
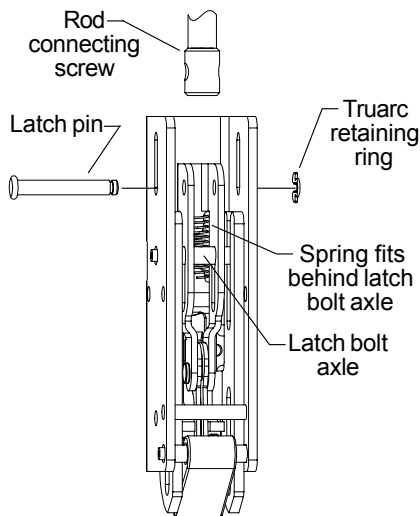

98/9927/27-F and 2227/27-F Top and Bottom Latches (98/9927/27-F Top Latch Shown)

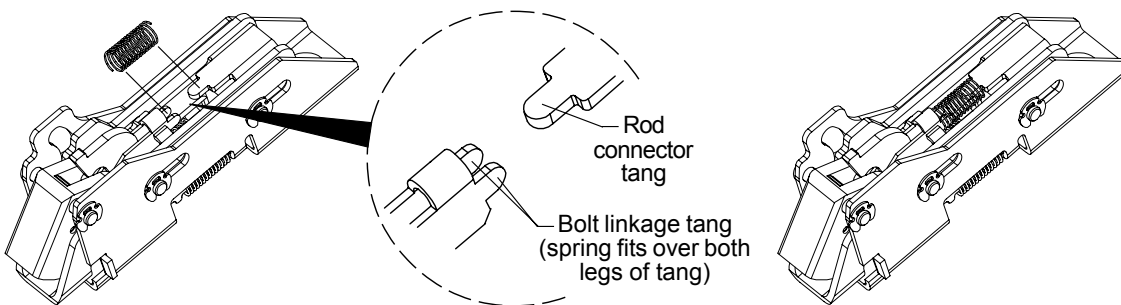

5. Surface Vertical Latch Parts

Part Name: 98/9927 Auxiliary Bolt Spring

Kit Location: Top drawer #5

Part Number: 090076-00 bulk, 10/pkg.

Use: 98/9927 and 2227 top latches

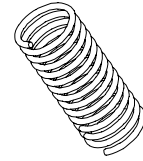

Installation: Place one end of spring over over auxiliary bolt tang. Compress spring and place free end of spring over latch case housing tang.

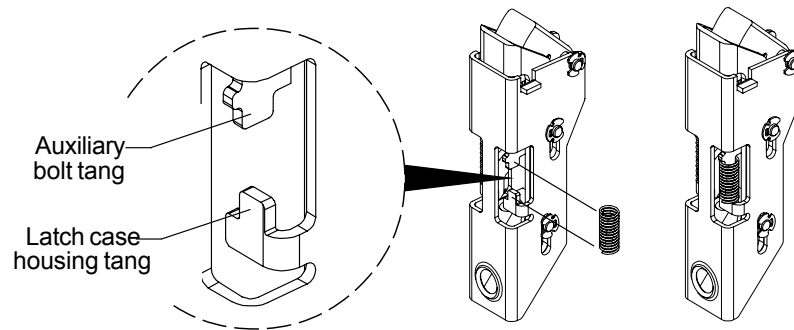

6. Concealed Vertical Latch Parts

Part Name: Ratchet Lever Spring

Kit Location: Middle drawer #7

Part Number: 090069-00 bulk, 2/pkg.

Use: 98/9947/47-F and 33/3547/47-F top latches

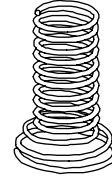

Installation: Place small end of spring over ratchet lever tang. Place large end of spring over pin in latch case.

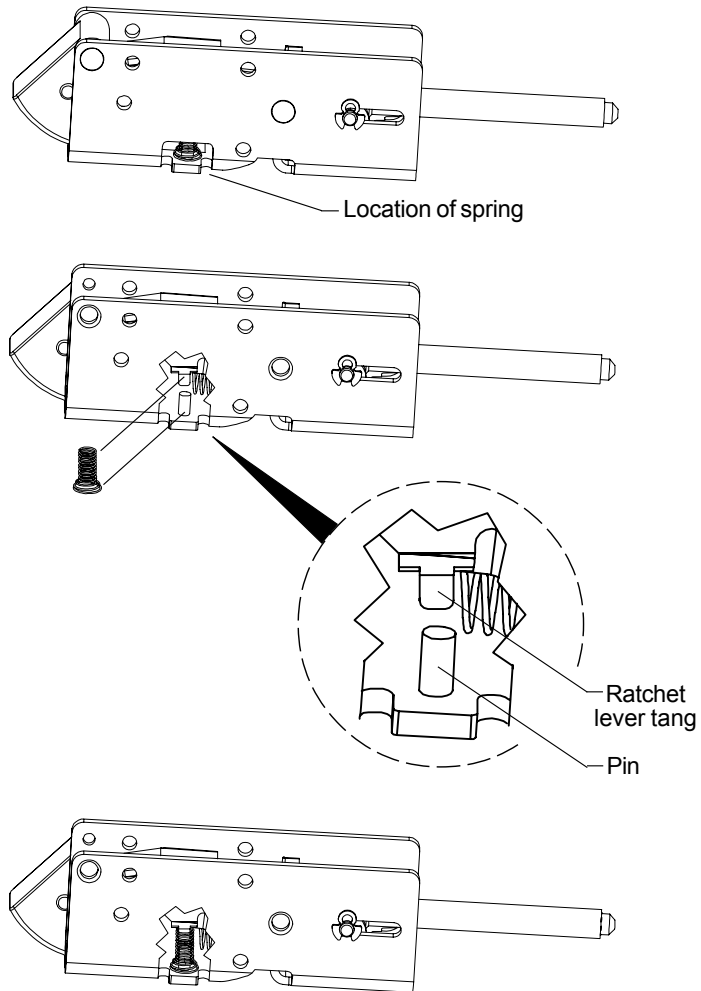

6. Concealed Vertical Latch Parts

Part Name: #10 External Tooth Lock Washer

Kit Location: Top drawer #3

Part Number: PKGSRV.1007 bulk, 10/pkg.

Use: To secure 98/9947 and 33/3547 latch mounting bracket

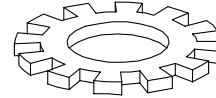

Installation: Use washer with screws that attach latch mounting bracket to door.

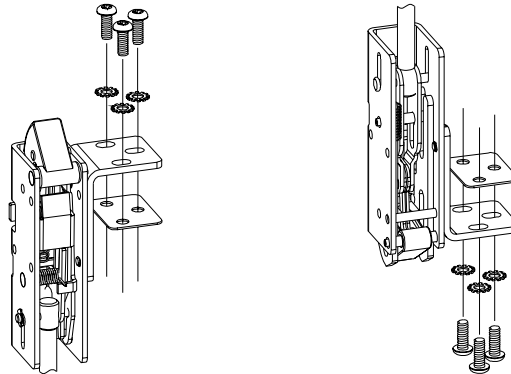

Part Name: Compression Spring-33/3547

Kit Location: Middle drawer #3

Part Number: 090066-00 bulk, 10/pkg.

Use: 98/9947 and 33/3547 top latch

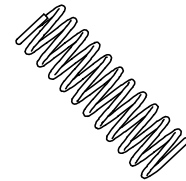

Installation: Place small end of spring on latch bolt linkage tang, other end on latch case tang.

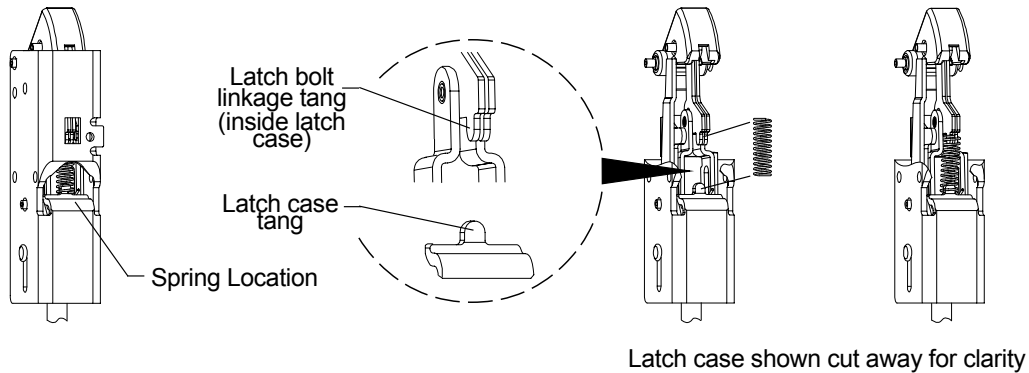

7. Mounting Hardware, Screws, and Retaining Rings

Part Name: 325 Sex Bolt Assembly

Kit Location: Top drawer #4

Part Number: 034902-32 bulk, 2/pkg.

Use: For mounting 98/99, 33A/35A, and 22 latches and latch mounting brackets made after Nov. 1998

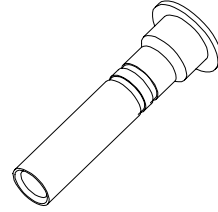

Installation: Drill mounting holes per template supplied with device, 13/32" diameter outside, 5/16" diameter inside. Hammer sex bolt through 13/32" diameter hole. #325 sex bolt takes 1/4-20 thread screw.

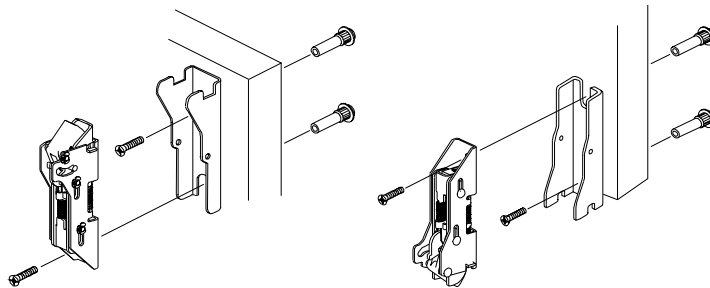

Part Name: 425 Sex Bolt Assembly

Kit Location: Top drawer #49

Part Number: 034302-32 bulk, 2/pkg.

Use: For mounting 98/99 and 22 device surface latches and latch mounting brackets made before Nov. 1998; for mounting 98/99, 33/35, and 22 device end cap brackets and center cases (EO applications)

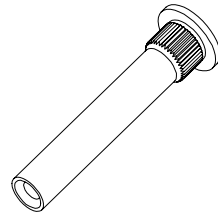

Installation: Drill mounting holes per template supplied with device, 13/32" diameter outside, 1/4" diameter inside. Hammer sex bolt through 13/32" diameter hole. #425 sex bolt takes 10-20 thread screw. (See diagram above)

7. Mounting Hardware, Screws, and Retaining Rings

Part Name: 10-12 x 10-24 x 1 PTHCS

Kit Location: Top drawer #13

Part Number: 900919-00 bulk, 2/pkg.

Use: 98/9927 and 2227 device rod guide assembly

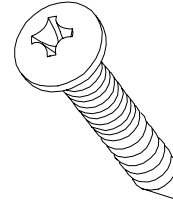

Installation: Use screws to mount 9927 rod guide assembly to door. For wood door, drill 1/8" diameter pilot holes. For metal door, use #25 drill and #10-24 tap.

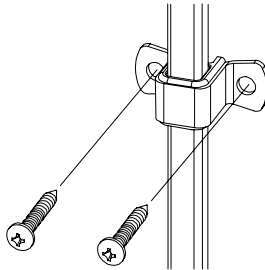

Part Name: 10-24 x 3/4 PPHMS

Kit Location: Middle drawer #2

Part Number: PKGSRV.1015 bulk, 10/pkg.

Use: 98/99, 33/35, and 22 device mechanism case mounting brackets

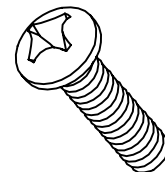

Installation: Use screws to mount 98/99, 33/35, and 22 device mechanism case mounting brackets to door. For metal door surface mount, prepare door with #25 drill and #10-24 tap. Screws also can be used with #425 sex bolts on 1 3/4" door.

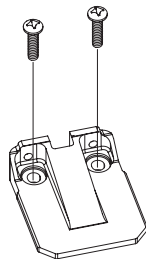

98/99 and 33/35 device mechanism case bracket

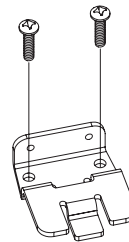

22 device mechanism case bracket

7. Mounting Hardware, Screws, and Retaining Rings

Part Name: 10-24 x 1 PPHMS

Kit Location: Middle drawer #9

Part Number: PKGSRV.1016 bulk, 20/pkg.

Use: 98/99, 33/35, and 22 device center cases

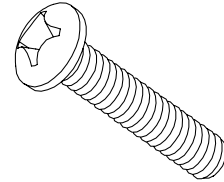

Installation: Use screws to mount 98/99, 33/35, and 22 device center cases to 1 3/4" hollow metal doors. For surface mount, prepare door with #25 drill and #10-24 tap. Also can be used for through-mounting to trim and with #425 sex bolts.

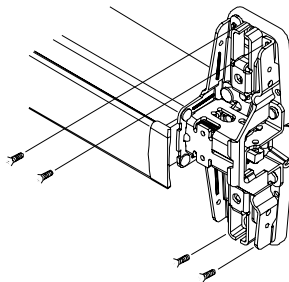

98/9927 center case shown

Part Name: 8-32 x 1/4 UFPHMS

Kit Location: Top drawer #6

Part Number: PKGSRV.1018 bulk, 20/pkg.

Use: 98/9927 and 33/3527 latch case covers



Installation: Place latch case cover over latch case and secure with two screws.

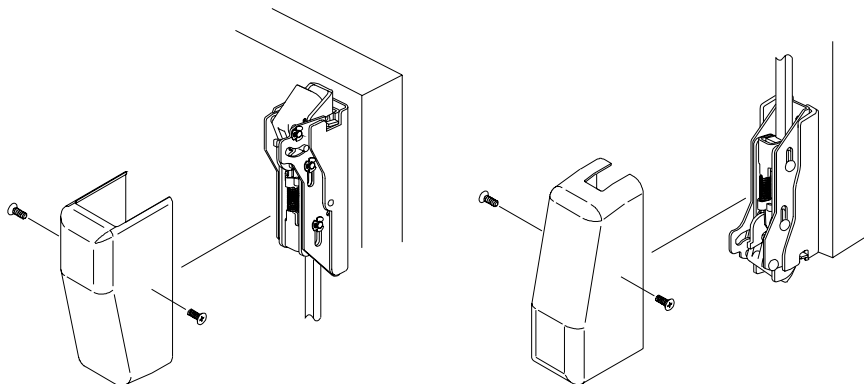

7. Mounting Hardware, Screws, and Retaining Rings

Part Name: 10-24 x 3/4 UFPHMS

Kit Location: Top drawer #1

Part Number: PKGSRV.1019 bulk, 10/pkg.

Use: 98/9927 and 2227 latches and latch mounting brackets made before Nov. 1998

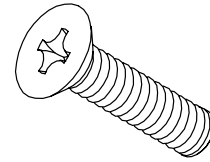

Installation: Use with #425 sex bolts. Drill mounting holes per template supplied with device, 13/32" diameter outside, 1/4" diameter inside. Hammer sex bolt through 13/32" diameter hole.

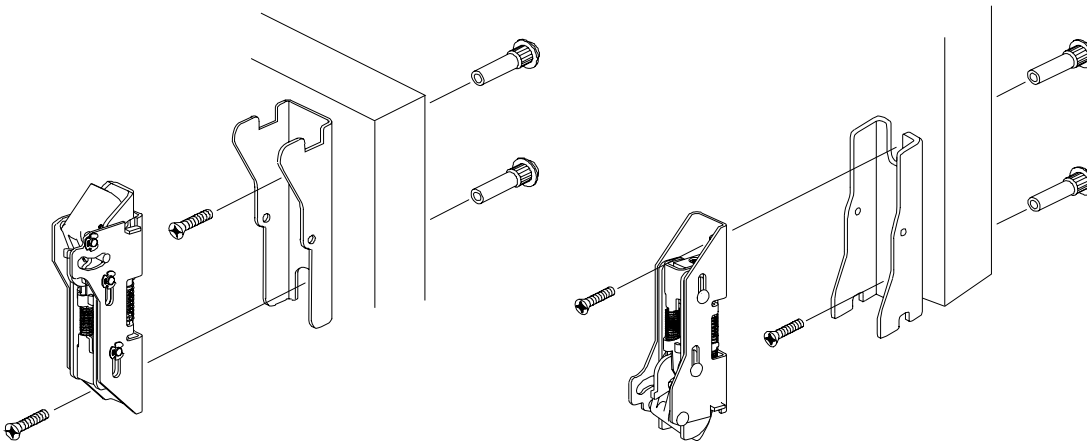

Part Name: 1/4-20 x 3/4 UFPHMS

Kit Location: Bottom drawer #7

Part Number: PKGSRV.1020 bulk, 10/pkg.

Use: 98/9927 and 2227 latches and latch mounting brackets made after Nov. 1998

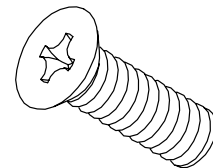

Installation: Use with #425 sex bolts. Drill mounting holes per template supplied with device, 13/32" diameter outside, 1/4" diameter inside. Hammer sex bolt through 13/32" diameter hole. (See diagram above.)

7. Mounting Hardware, Screws, and Retaining Rings

Part Name: 8-18 x 3/8 UFPHSMS

Kit Location: Middle drawer #11

Part Number: 900892-32 bulk, 4/pkg.

Use: 98/99 center case cover

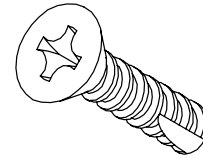

NOTE
900892-32 finish is chrome.
Other finishes available.

Installation: Secure center case cover with four screws.

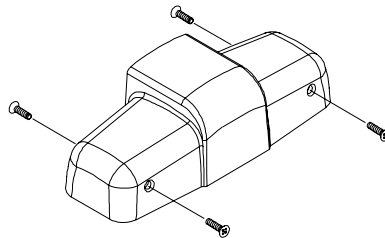

Part Name: 12-24 Mechanism Case Screw

Kit Location: Bottom drawer #12

Part Number: 090073-00 bulk, 10/pkg.

Use: 98/99 and 33/35 devices; secures center case cover mounting bracket to mechanism case

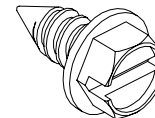

Installation: Remove two pine tree clips and replace with screws.

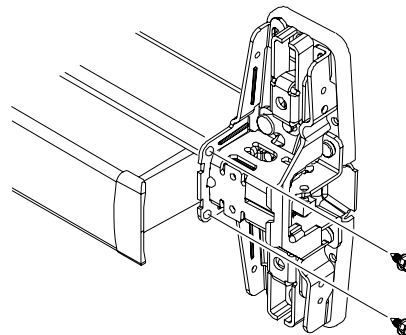

98/99 device shown

7. Mounting Hardware, Screws, and Retaining Rings

Part Name: Truarc Retaining Ring T5304-18

Kit Location: Top drawer #2

Part Number: 090107-00 bulk, 10/pkg.

Use: 98/99 and 22 rim latch bolt axle,
98/9927 and 98/9947 center case,
98/99, 33/35, and 22 main control link to control linkage



Installation: Use flat blade screwdriver to push ring over groove in pin so ring snaps in place.

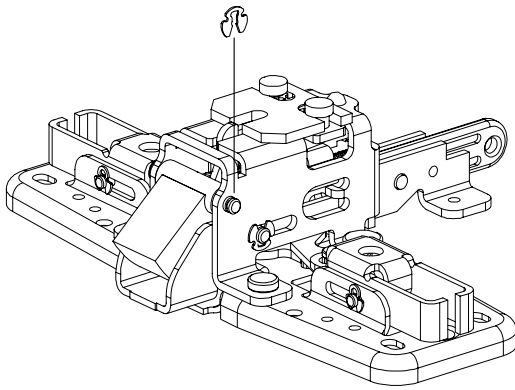

98/99 and 22 rim
latch bolt axle (98/99 shown)

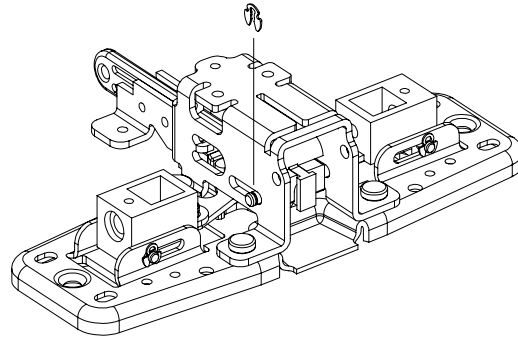

98/9927 and 98/9947
center case

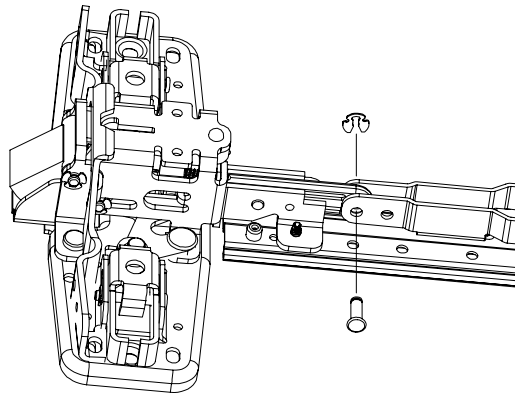

98/99 and 22
main control link to control
linkage (98/99 shown)

7. Mounting Hardware, Screws, and Retaining Rings

Part Name: 10-32 x 1/4 UFPHMS with Nylock

Kit Location: Bottom drawer #1

Part Number: 090059-00 bulk, 6/pkg.

Use: 98/9947 and 33/3547 top and bottom latch mounting brackets



Installation: Use screws to secure latch mounting brackets to latches.

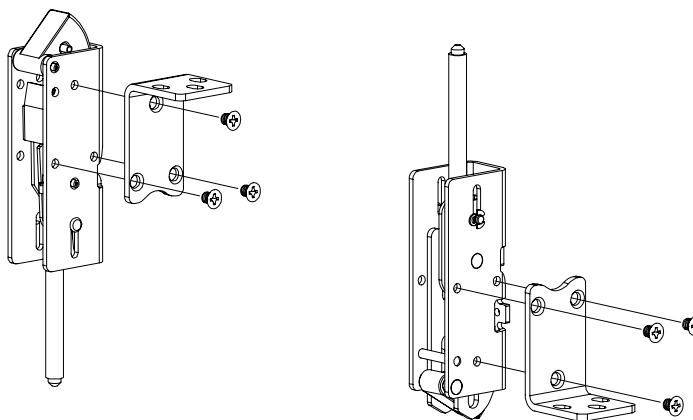

Part Name: 10-24 x 3/4 FPHMS

Kit Location: Bottom drawer #8

Part Number: PKGSRV.1023 bulk, 10/pkg.

Use: 299 strike

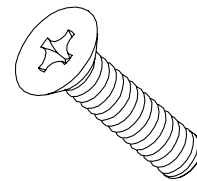

Installation: Prepare mounting holes per template supplied with device using #25 drill and #10-24 tap.

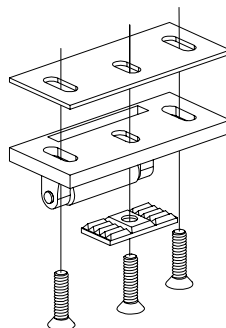

8. Trim Parts

Part Name: Shear Pin

Kit Location: Middle drawer #10

Part Number: PKGSRV.1010 bulk, 50/pkg.

Use: 991, 992, and 994 trim made after Jan. 1993

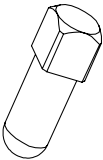

Installation: This procedure is for 992L R&V trim. For other trim, see trim instructions.

- 1. Remove trim from door.
- 2. Remove two lift springs (A).
- 3. Push slider up, then pull out (B).
- 4. Use retaining ring pliers to remove retaining ring (C).
- 5. Remove washer and cam (D).
- 6. Loosen set screw with 3/32" hex wrench and remove broken shear pin (E).
- 7. Place lever in desired position, RHR or LHR (F).
- 8. Insert new shear pin with head pointed down and tighten shear pin set screw.
- 9. Install cam. "R" faces out for RHR door, "L" faces out for LHR door (G).
- 10. Install washer, retaining ring, slider, and two lift springs.

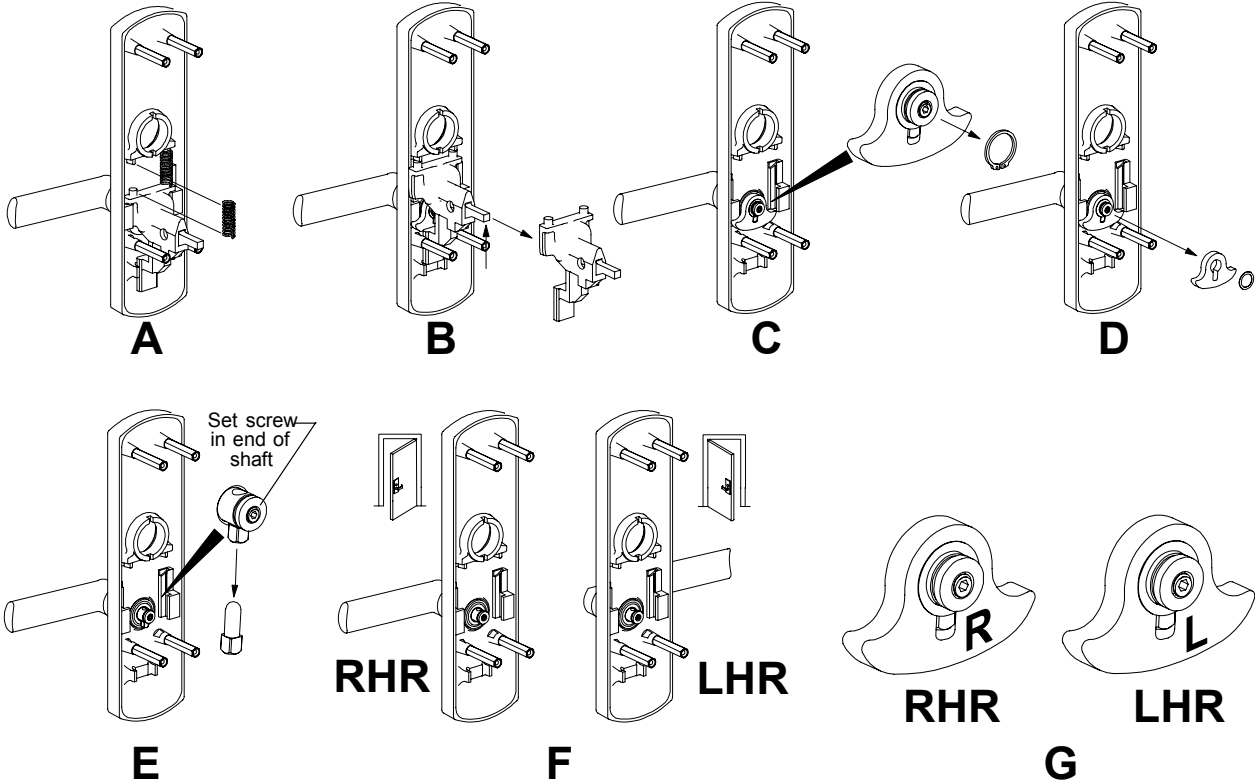

8. Trim Parts

Part Name: Cylinder Retaining Cup

Kit Location: Top drawer #15

Part Number: 968201-89 unit

Use: 880, 990, 991, 992, and 994 trim with rim cylinders

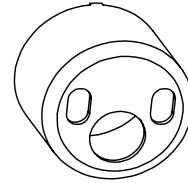

Installation: With trim off door, insert cylinder through trim. Install cylinder retaining cup over trim so tabs on cylinder retaining cup align with notches on trim. Secure cylinder retaining cup to cylinder with screws.

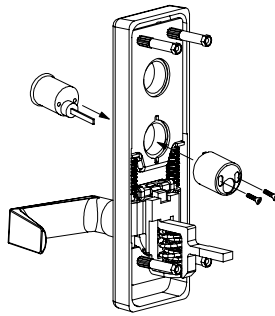

Part Name: 992/994 Lift Spring

Kit Location: Bottom drawer #13

Part Number: 971573-00 unit; PKGSRV.1011 bulk, 20/pkg.

Use: 992/994 trim

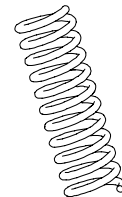

Installation: See pictures below for 992 and 994 spring installation.

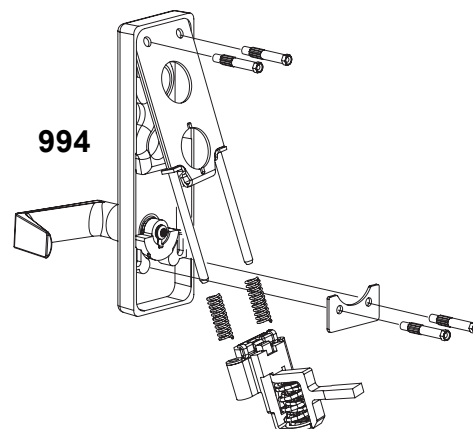
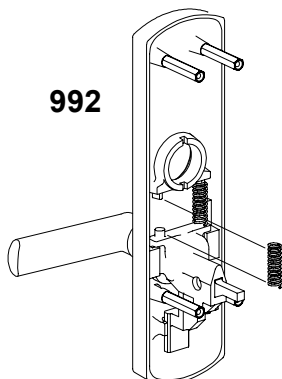

8. Trim Parts

Part Name: Hex Stud-994/996 Trim

Kit Location: Top drawer #4

Part Number: 971585-89 unit

Use: 994 and 996 trim

Installation: Screw stud into trim housing. Do not over-tighten.

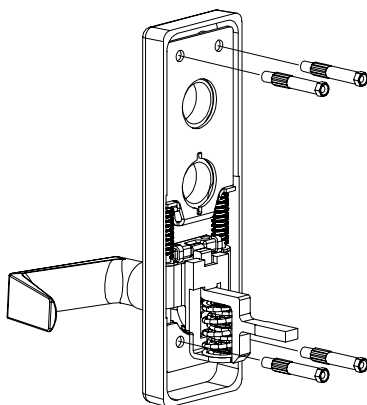
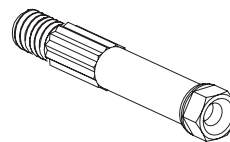

Part Name: 1/4-20 Hex Stud

Kit Location: Middle drawer #5

Part Number: 971440-89 unit; PKGSRV.1012 bulk, 10/pkg.

Use: 991 and 992 trim made after March 1997

Installation: Screw stud into trim housing. Do not over-tighten.

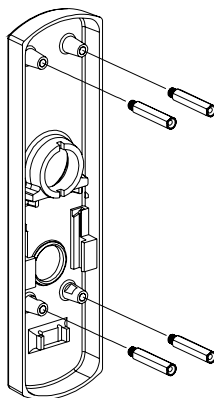
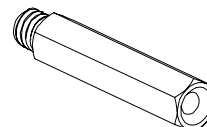

8. Trim Parts

Part Name: 10-24 x 1 3/8 PPHMS

Kit Location: Top drawer #12

Part Number: PKGSRV.1022 bulk, 10/pkg.

Use: To mount 991 and 992 trim on 1 3/4" doors

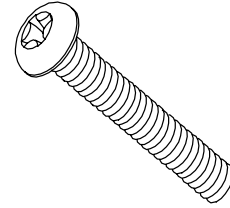

Installation: Bolt through device and door to hex studs on trim.

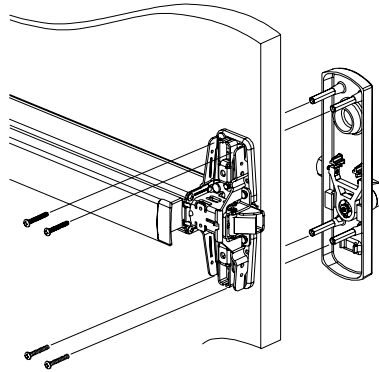

Part Name: Truarc Retaining Ring 5160-42

Kit Location: Middle drawer #6

Part Number: 964285-00 unit; PKGSRV.1013 bulk, 10/pkg.

Use: To secure cam on 991 and 992 trim

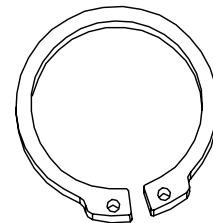

Installation: Use retaining ring pliers to open retaining ring. Slip ring over shaft and position ring in groove in shaft.

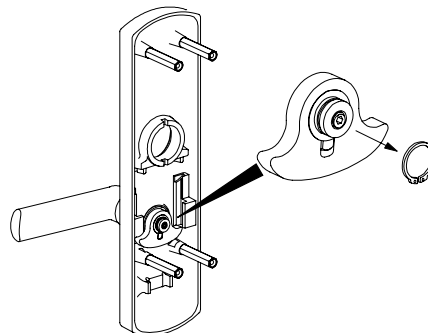

8. Trim Parts

Part Name: Wave Spring Washer

Kit Location: Middle drawer #1

Part Number: 090103-00 bulk, 10/pkg.

Use: Used on 992 and 370 series controls to eliminate excessive lever movement perpendicular to the face of the door



Installation: This procedure is for 992L R&V trim. For other trim, see trim instructions.

1. Remove trim from door.
2. Remove two lift springs (A).
3. Push slider up, then pull out (B).
4. Use retaining ring pliers to remove retaining ring (C).
5. Replace or install washer (D).
6. Install retaining ring, slider, and two lift springs.

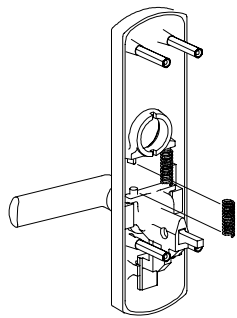

A

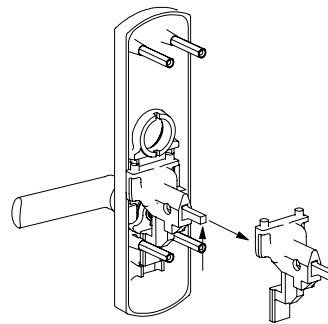

B

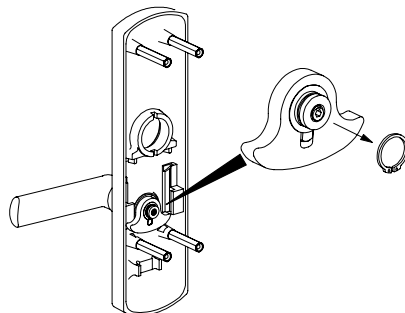

C

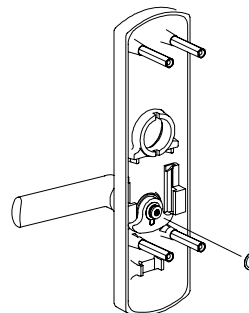

D

8. Trim Parts

Part Name: 1/4-20 x 5/8 Socket Set Screw

Kit Location: Bottom drawer #10

Part Number: 964353-76 unit

Use: 992 trim

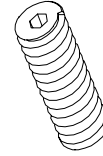

Installation: Loosen or remove set screw. Slide the R&V finger in or out to align the mark for the door thickness with the surface indicated. When aligned, tighten the set screw with a 1/8" hex wrench.

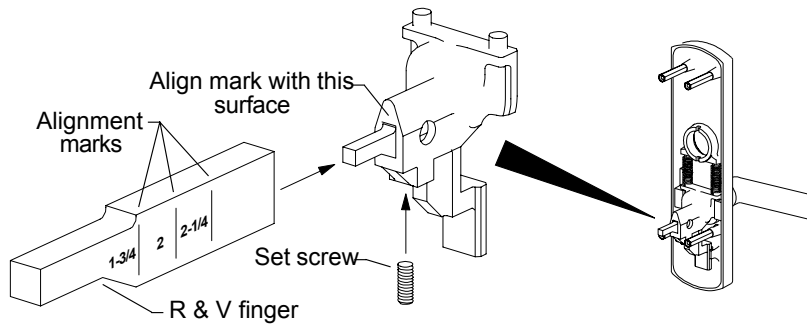

Appendix A: Device Lubrication

Devices are lubricated before delivery. Additional periodic lubrication will increase device life by inhibiting excessive wear of moving parts. Lubricate every four months with Duralube or equivalent. Recommended surfaces for lubrication are shown in the diagrams below.

Lubricate indicated surfaces on both sides of device.

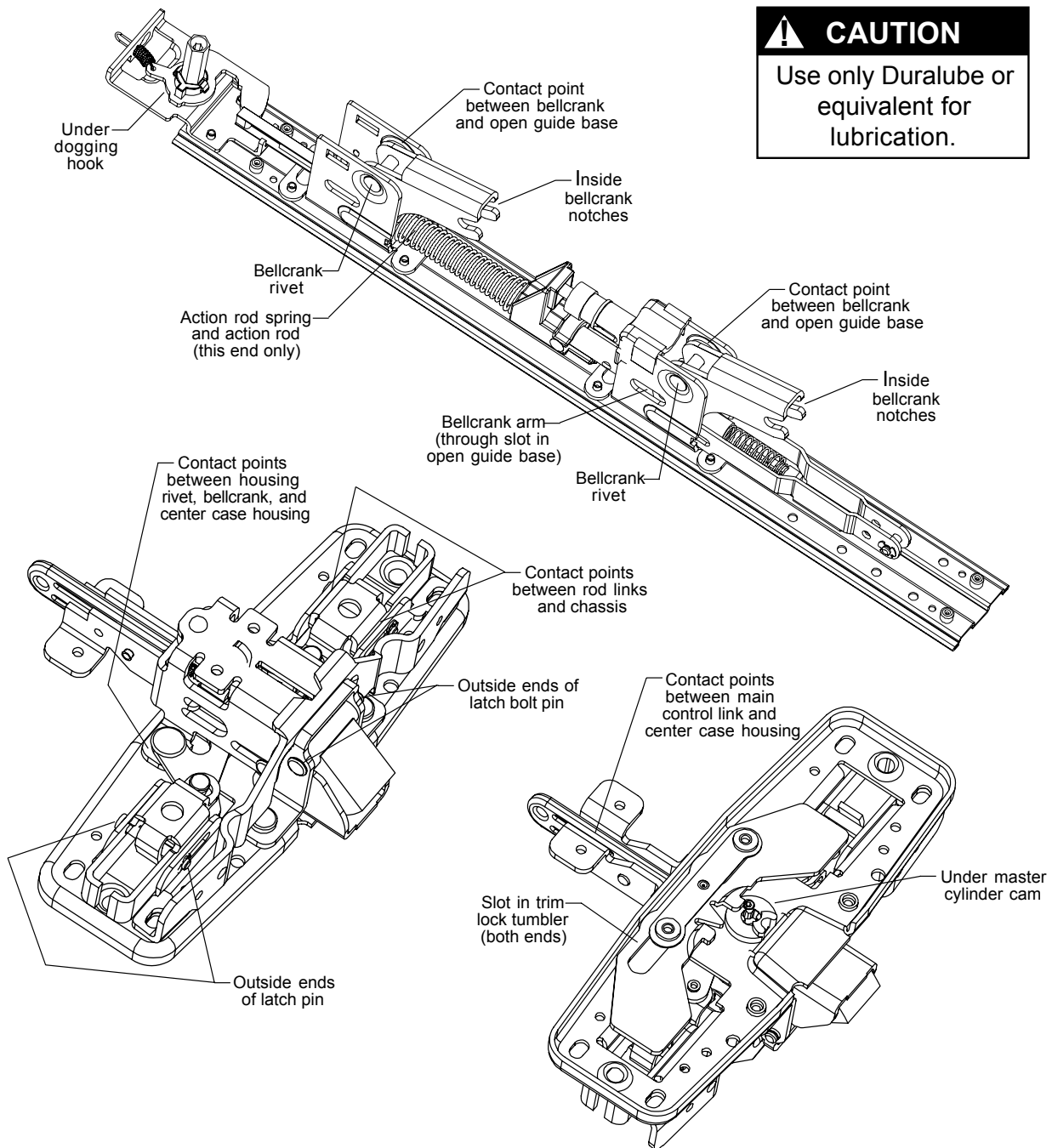

Appendix B: Latch Lubrication

Latches are lubricated before delivery. Additional periodic lubrication will increase latch life by inhibiting excessive wear of moving parts. Lubricate every four months with Duralube or equivalent. Recommended surfaces for lubrication are marked with ● in the diagrams below.

⚠ CAUTION
Use only Duralube or equivalent for lubrication.

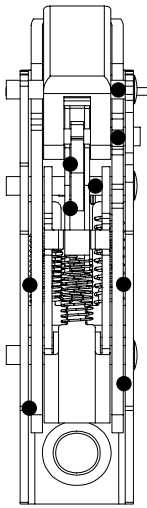

Surface latch, top

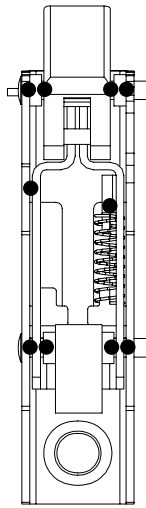

Pullman latch, top

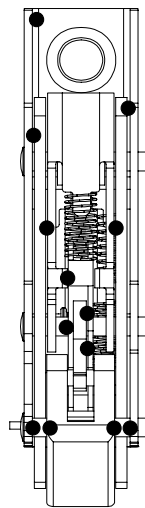

Surface latch, bottom
(front of latch)

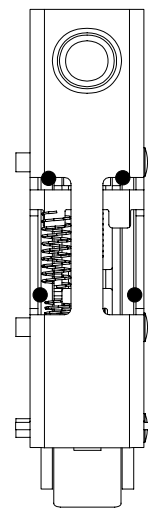

Surface latch, bottom
(back of latch)

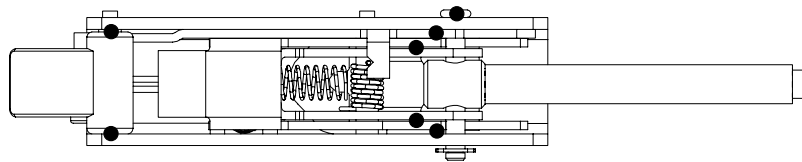

Concealed latch, top

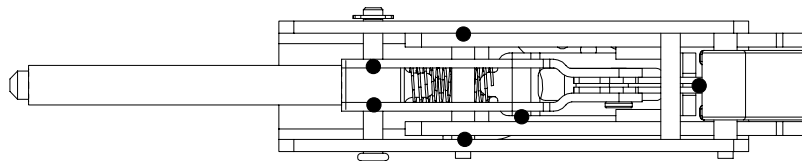

Concealed latch, bottom

Index by Part Number

Part Number	Part Description	Page Number
034302-32 (bulk)	425 Sex Bolt Assembly	7-1
034902-32 (bulk)	325 Sex Bolt Assembly	7-1
050156-00 (bulk)	Tailpiece Guide	1-3
050491-00 (unit)	Shock Absorber and Holder Assembly	3-3
050524-00 (unit)	Mechanism Case Mounting Bracket	3-1
090031-00 (bulk)	Control Link Pin-Touch Bar Device	1-2
090036-00 (bulk)	Anti-Rattle Spring-33/35/98/99	3-2
090040-00 (bulk)	Hex Dogging Shaft	2-1
090041-00 (bulk)	Dogging Spring	2-3
090042-00 (bulk)	Dogging Adapter Spring	2-2
090045-00 (bulk)	Cylinder Dog Actuator	2-4
090046-00 (bulk)	CD Dogging Plug	2-4
090049-00 (bulk)	Pushbar Guide (front)	3-4
090049-00 (bulk)	Pushbar Guide (rear)	3-5
090054-00 (bulk)	1/8 x 7/16 Roll Pin	4-2
090059-00 (bulk)	10-32 x 1/4 UFPHMS with Nylock	7-7
090065-00 (bulk)	Bolt Return Spring	5-2
090066-00 (bulk)	Compression Spring-33/3547	6-2
090069-00 (bulk)	Ratchet Lever Spring	6-1
090073-00 (bulk)	12-24 Mechanism Case Screw	7-5
090074-00 (bulk)	NL DriveScrew-98/99 Device	1-2
090075-00 (bulk)	Rod Extension Connector	4-1
090076-00 (bulk)	98/9927 Auxiliary Bolt Spring	5-3
090103-00 (bulk)	Wave Spring Washer	8-5
090107-00 (bulk)	Truarc Retaining Ring T5304-18	7-6
112063-32 (unit)	98/9927 Rod Guide Assembly (stainless)	4-2
15-445-00 (unit)	Hex Dogging Replacement Kit	2-1
900892-00 (bulk)	8-18 x 3/8 UFPHSMS (chrome)	7-5
900919-00 (bulk)	10-12 x 10-24 x 1 PTHCS	7-2
900597-00 (bulk)	End Cap Mounting Screw	3-1
945521-89 (unit)	Shim-264/299F/499F Strike	5-1
964285-00 (unit)	Truarc Retaining Ring 5160-42	8-4
964353-76 (unit)	1/4-20 x 5/8 Socket Set Screw	8-6
968201-89 (unit)	Cylinder Retaining Cup	8-2
969298-89 (unit)	Extension Rod Drill Template-2227/98/9927	4-1
971585-89 (unit)	Hex Stud-994/996 Trim	8-3
970321-89 (unit)	299 Strike Shim	5-1
970441-89 (unit)	NL DriveScrew-98/99 Device	1-2
971440-89 (unit)	1/4-20 Hex Stud	8-3

Index by Part Number (continued)

Part Number	Part Description	Page Number
971573-00 (unit)	992L Lift Spring	8-2
PKGSRV.1007 (bulk)	#10 External ToothLock Washer	6-2
PKGSRV.1010 (bulk)	Shear Pin	8-1
PKGSRV.1011 (bulk)	992L Lift Spring	8-2
PKGSRV.1012 (bulk)	1/4-20 Hex Stud	8-3
PKGSRV.1013 (bulk)	Truarc RetainingRing 5160-42	8-4
PKGSRV.1015 (bulk)	10-24 x 3/4 PPHMS	7-2
PKGSRV.1016 (bulk)	10-24 x 1 PPHMS	7-3
PKGSRV.1018 (bulk)	8-32 x 1/4 UFPHMS	7-3
PKGSRV.1019 (bulk)	10-24 x 3/4 UFPHMS	7-4
PKGSRV.1020 (bulk)	1/4-20 x 3/4 UFPHMS	7-4
PKGSRV.1022 (bulk)	10-24 x 1 3/8 PPHMS	8-4
PKGSRV.1023 (bulk)	10-24 x 3/4 FPHMS	7-7



Customer Service

1-877-671-7011 www.allegion.com/us