

INSTALLATION INSTRUCTIONS FOR FULL CONCEALED HINGES

A110HD/LL, A111HD/LL, A130HD, A135HD, A140HD/LL, A150HD/LL, A160HD/LL
A240HD/LL, A260HD/LL, A270HD/LL, A280HD/LL & A410HD/LL

- A. All uncut standard length hinges are non-handed and can be used for right or left hand doors.
- B. Standard length hinges are supplied slightly shorter than nominal door height to accommodate threshold and carpeting clearances.

CUTTING THE HINGE TO FIT

- Keep hinge in the closed position
- Determine **HANDING** if required. Not all hinges will become handed after cutting.
- Cut one end of the hinge only. Cut end will be installed at the bottom (Six-hole pattern remains at the top)
- Use a Metal Cutting Saw cut through the gear cap first.

Note: If cut length interferes with a set screw bearing remove it and switch it with a plain bearing above the cut location.

FRAME PREP

With the hinge in the open position

1. Locate the top of the hinge 1/8" below the header

With the frame leaf flange tight against the frame

2. Mark or Center Punch hole locations

Note: If using wood screws drill a 5/32" pilot hole

DO NOT ATTACH HINGE TO FRAME AT THIS TIME

ATTACH THE HINGE TO THE DOOR

4. Position Door Leaf on door. Door leaf alignment flange or door leaf lip must be seated against door edge.
5. Align the top end of the hinge to be absolutely flush with the top of the door.
6. Mark or Center Punch hole locations
7. Using the provided Self Drilling/Thread Forming Screws and the proper drive bit please proceed to attach the hinge to the door

Note: If using wood screws drill a 5/32" pilot hole.

ATTACHING DOOR TO FRAME

8. Position door 90 degrees to frame
9. Shim door to the proper height to line up the screw holes in hinge frame leaf with the marks at the top of the frame.
10. Install two screws at the top of the hinge to hold in place
11. Remove shim and align the remaining holes. Install two additional screws in the middle and at the bottom.
12. Check door for proper swing and clearance before installing remaining screws, making necessary adjustments.
13. Install the remaining fasteners after any adjustments are made.

REINFORCING AND RIVNUTS

- No reinforcing is necessary except on extremely high-frequency, extremely heavy or extra-wide doors.
- Rivnuts are recommended for use in the frame when the door exceeds 450lbs.

Note: RIVNUTS are **not** to be used with Fire Rated Hinges

PAIRS OF DOORS WITH MULLIONS

- If the mullion is between the doors, install as single doors.
- If the mullion is behind the doors, install as a double doors.

GROUT/SLUSHED-IN FRAMES

It is recommended that a mudguard be installed behind the frame for ease of installation. Do not use self-drill screws with grouted steel frames without a mudguard. If no mudguard has been used, drill holes through frame and remove grout for screw clearances. Do not oversize hole.

SCREW DETAIL	
FRAME	12-24 x 3/4" PHILLIPS FLAT HEAD, UNDERCUT, SELF DRILLING, THREAD FORMING TEK MACHINE SCREW
DOOR	12-24 x 3/4" PHILLIPS FLAT HEAD, UNDERCUT, SELF DRILLING, THREAD FORMING TEK MACHINE SCREW

Note: #12 x 1-1/2" FLAT HEAD UNDERCUT WOOD SCREWS AVAILABLE UPON REQUEST

The following actions will void any warranty, expressed or implied.

- Failure to Install the hinge according to ABH's specifications and requirements
- Use of Fasteners other than those supplied with the hinge.
- Unauthorized field modifications including removing any of the bearings, altering the original finish or painting the hinge.

UL FIRE RATED STUDS FOR INSTALLATION

FULL CONCEALED ALUMINUM GEARED HINGES

MODELS A110HD/LL, A111HD/LL, A140HD/LL, A150HD/LL, A160HD/LL, A240HD/LL, A260HD/LL
A270HD/LL, A280HD/LL & A410HD/LL

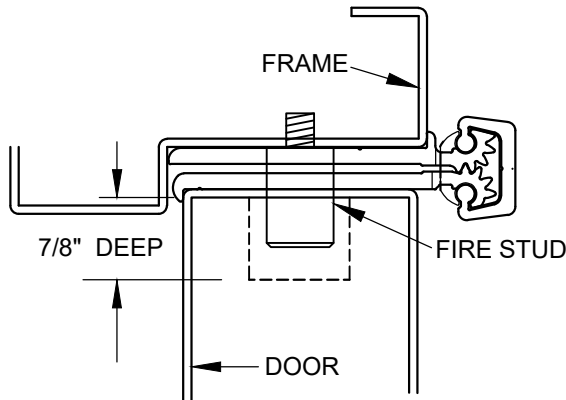

**DOOR SHOWN CLOSED WITH FIRE STUD IN PLACE
USING MODEL A240HD HINGE**

NOTES:

1. INSTALL HINGE PER INSTALLATION INSTRUCTIONS FOR EACH MODEL.
2. FOR THE FRAME SIDE - DRILL AND TAP (4) 12-24 HOLES FOR FIRE STUDS.
3. FOR THE DOOR SIDE - DRILL (4) 3/4" DIA. HOLES IN THE DOOR TO CORRESPOND TO THE STUD HOLES IN THE FRAME SIDE.
4. INSERT STUDS IN THE FOUR (4) TAPPED FRAME HOLES, TIGHTEN SECURELY.
5. SLOWLY CLOSE DOOR MAKING SURE THAT THE STUDS ARE PROPERLY ALIGNED.
6. MINOR INTERFERENCE CAN BE TAKEN CARE OF WITH A ROUND METAL FILE.

DIMENSION					
"A" HINGE LENGTH	79"	83"	85"	95"	120"
"B"	12"	12"	12"	12"	12"
"C"	25-3/8"	27-3/8"	28-3/8"	32-3/8"	42-1/2"
"D"	53-5/8"	55-5/8"	56-5/8"	62-5/8"	77-1/2"
"E"	67"	71"	73"	83"	108"

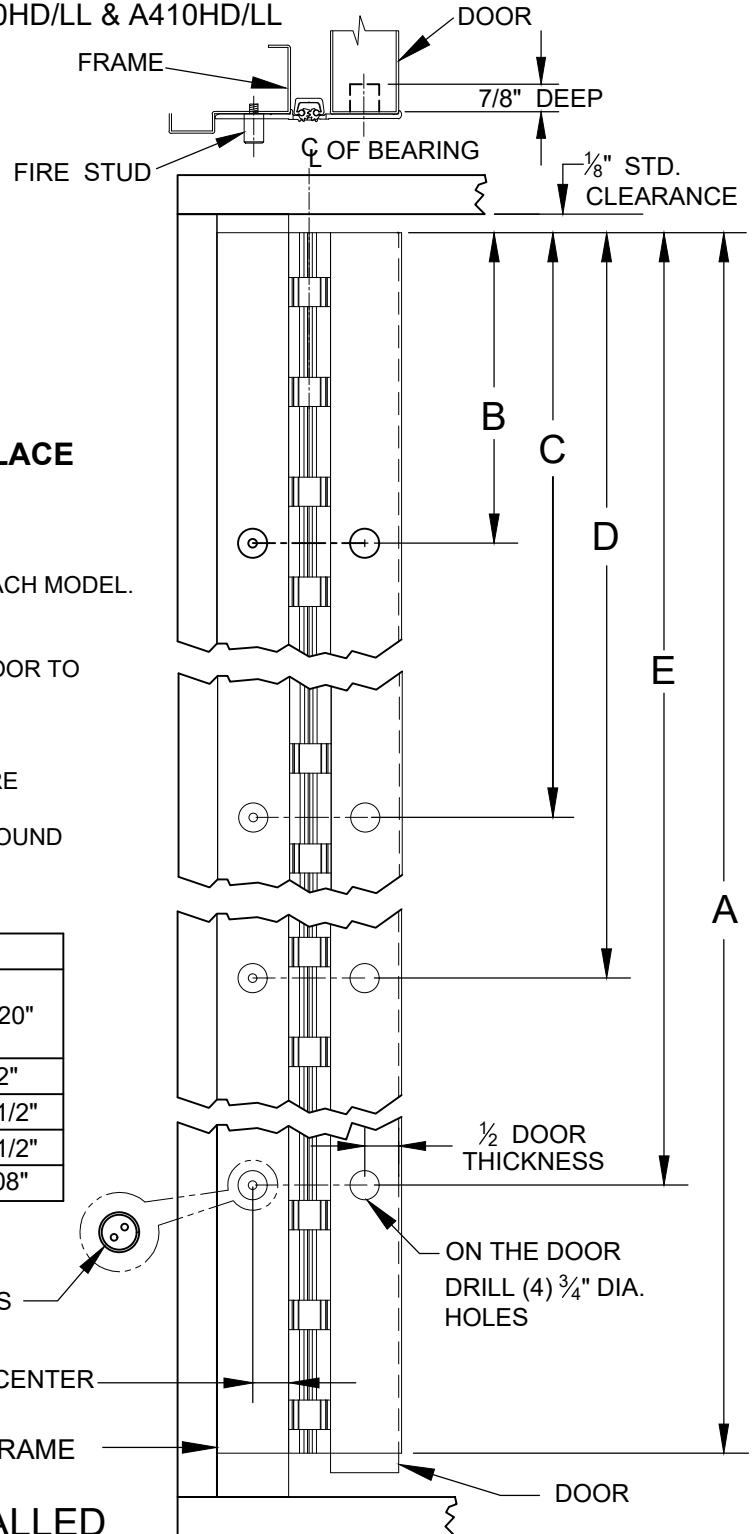

DOOR SHOWN OPEN 180°

ON THE FRAME, DRILL AND TAP (4) 12-24 HOLES

1/2 THE DOOR THICKNESS + 1/32" FROM CENTER OF HOLE TO EDGE OF FRAME

1/2 DOOR THICKNESS

ON THE DOOR DRILL (4) 3/4" DIA. HOLES

**ALL FOUR (4) STUDS MUST BE INSTALLED
TO COMPLY WITH U.L. RATING**

FIRE STUD - FULL CONCEALED-03.DWG



www.abhmf.com
E-mail: abhinfo@abhmf.com
Architectural Builders Hardware Mfg., Inc.
1222 Ardmore Ave., Itasca, IL 60143
630.875.9900; FAX 800.9FAXABH (932.9224)

© 2021 ABH Mfg., Inc.
printed in USA

**FIRE STUD -
FULL CONCEALED**

PAGE 1 OF 1
REVISED 11-22-21

**A110HD - "EA" OPTION, EASY ACCESS CONCEALED ELECTRIFICATION,
ALUMINUM GEARED HINGE**

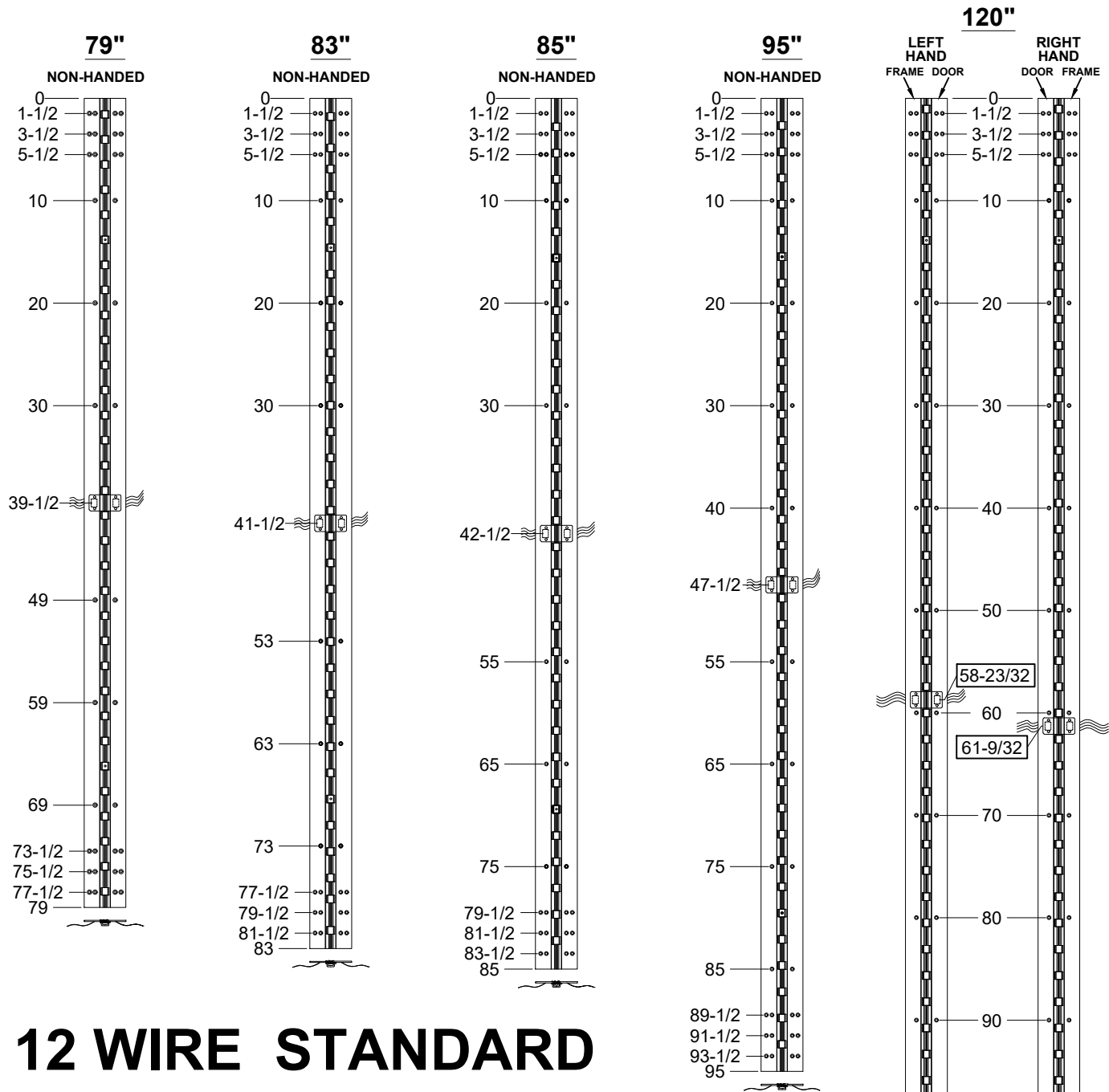

12 WIRE STANDARD

NOTES:

- 1. HINGES CUT TO CUSTOM LENGTH ARE CUT FROM BOTTOM OF HINGE. CUSTOM CUT HINGE REQUIRES HANDING.



STANDARD HINGE SIZES & SCREW DETAIL					
NOMINAL DOOR HEIGHT	6'8"	7'0"	7'2"	8'0"	10'0"
ACTUAL HINGE LENGTH	79"	83"	85"	95"	120"
FRAME	12-24 x 3/4" PHILLIPS FLAT HEAD, UNDERCUT, SELF DRILLING, THREAD FORMING TEK MACHINE SCREW				
DOOR	12-24 x 3/4" PHILLIPS FLAT HEAD, UNDERCUT, SELF DRILLING, THREAD FORMING TEK MACHINE SCREW				
	18	18	18	20	23



www.abhmfg.com
 E-mail: abhinfo@abhmfg.com
 Architectural Builders Hardware Mfg., Inc.
 1222 Ardmore Ave., Itasca, IL 60143
 630.875.9900; FAX 800.9FAXABH (932.9224)

A110HD-EA OPTION, EASY ACCESS CONCEALED ELECTRIFICATION-1-03.DWG

**A110HD - "EA" OPTION EASY ACCESS
CONCEALED ELECTRIFICATION**

© 2020 ABH Mfg., Inc.
printed in USA

**A110HD - "EA" OPTION "EA" OPTION EASY ACCESS CONCEALED ELECTRIFICATION,
ALUMINUM GEARED HINGE**

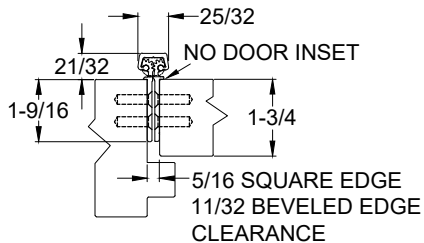
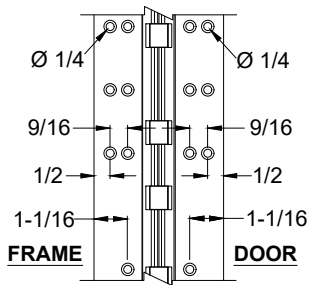

CLOSED POSITION

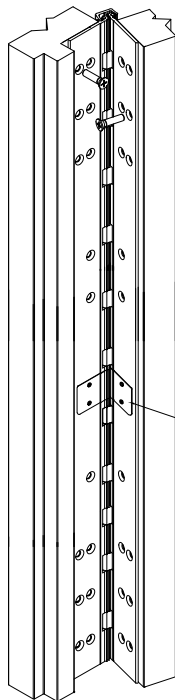

**ISOMETRIC VIEW
~90° OPENING**

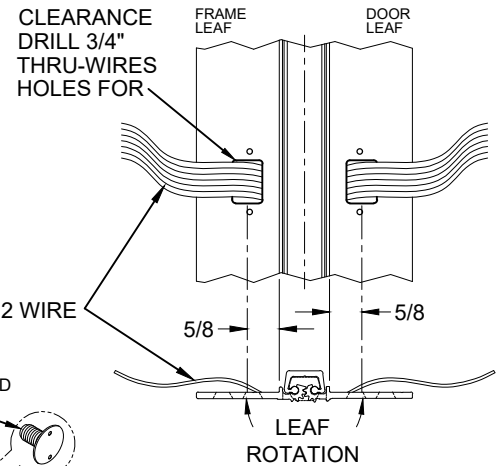

WIRE TRANSFER VIEW

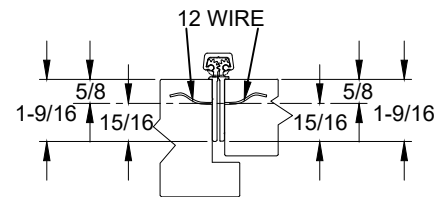

WIRE TRANSFER VIEW

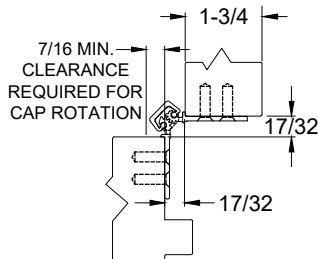

90° OPENING

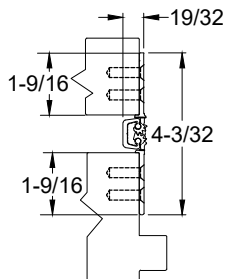

180° OPENING

NOTES:

1. MOLEX CONNECTOR OPTION AVAILABLE - SUFFIX "EZ".

* SPECIFY ELECTRIFIED HARDWARE MANUFACTURER FOR CONNECTOR COMPABILITY

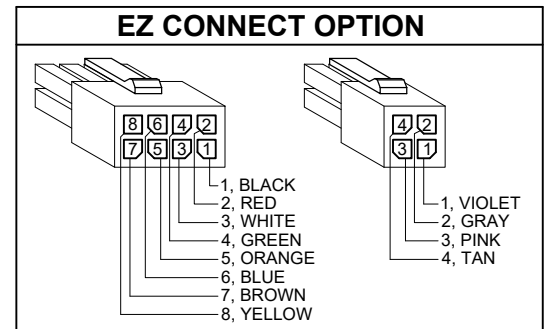

SPECIFICATION:

- DESCRIPTION:** SINGLE CONDUCTOR #22 AWG MINIATURE HOOK-UP WIRE FOR APPLICATIONS REQUIRING EXTREME FLEXIBILITY.
- CONDUCTOR:** #22 AWG 168/44 (0.002") SOFT BARE COPPER LHL.
- INSULATION:** PROPRIETARY FORMULATION PVC 0.010" NOM. WALL MEETS VW-1 FLAME REQUIREMENT.
- DIAMETER:** 0.053" ± 0.003".
- RESISTANCE:** 16.7 OHMS MAX. @ 20°C, PER 1000 FT.
- VOLTAGE RATING:** 600 VOLTS RMS, DEPENDING ON SPECIFICATION.
- AVAILABLE AS RoHS COMPLIANT.**



www.abhmfg.com
E-mail: abhinfo@abhmfg.com
Architectural Builders Hardware Mfg., Inc.
1222 Ardmore Ave., Itasca, IL 60143
630.875.9900; FAX 800.9FAXABH (932.9224)

**A110HD - "EA" OPTION EASY ACCESS
CONCEALED ELECTRIFICATION**

© 2020 ABH Mfg., Inc.
printed in USA

A110HD - "EA" & "R" ELECTRICAL MODIFICATION WITH REMOVABLE OPTION

120"

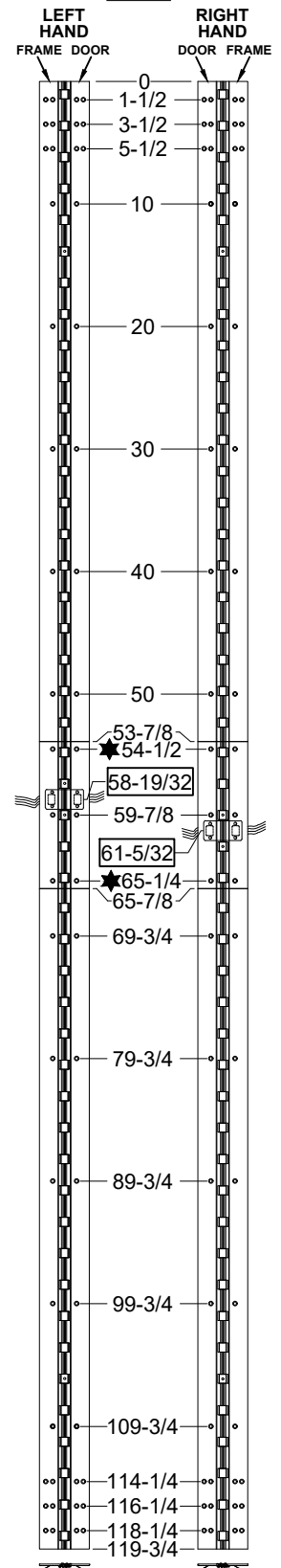
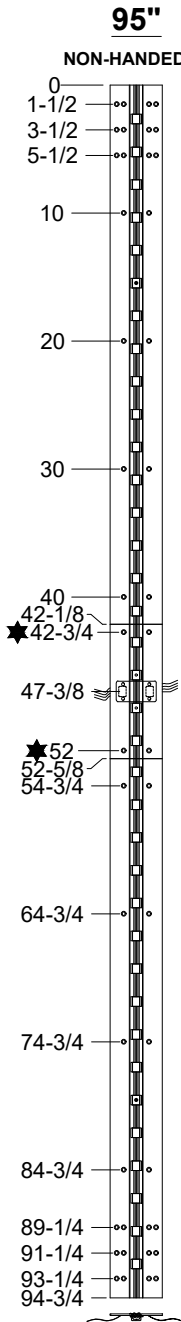
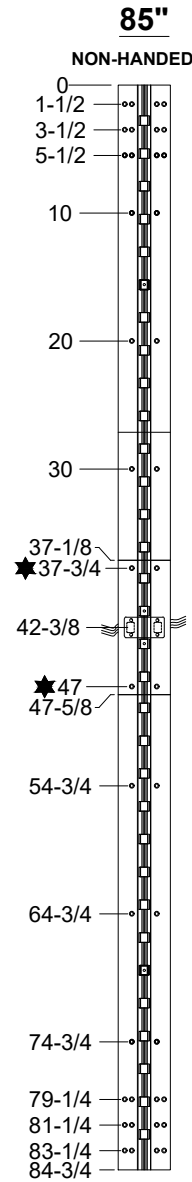
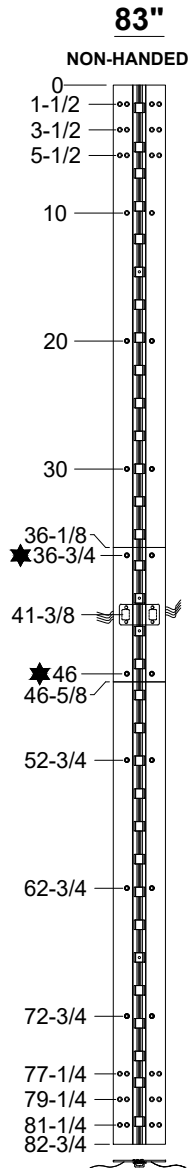
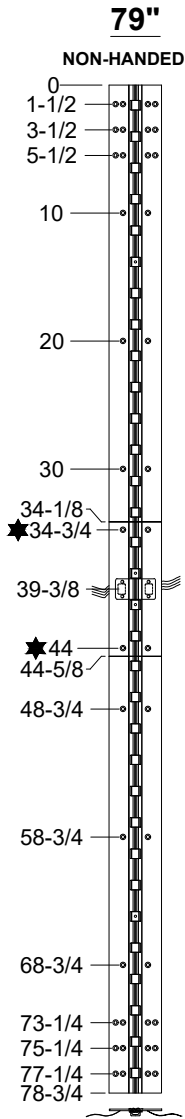

12 WIRE STANDARD

NOTES:

1. HINGES CUT TO CUSTOM LENGTH ARE CUT FROM BOTTOM OF HINGE. CUSTOM CUT HINGE REQUIRES HANDING.



R = REMOVABLE, (3) INDIVIDUAL HINGES, THRU WIRE CAN BE REMOVED TO ACCESS WIRES.

★ = MANUFACTURING TO ADD (4) COUNTERSINK THRU HOLES FOR #12 FLAT HEAD SCREW.

STANDARD HINGE SIZES & SCREW DETAIL

NOMINAL DOOR HEIGHT	6'8"	7'0"	7'2"	8'0"	10'0"	
ACTUAL HINGE LENGTH	79"	83"	85"	95"	120"	
FRAME	12-24 x 3/4" PHILLIPS FLAT HEAD, UNDERCUT, SELF DRILLING, THREAD FORMING TEK MACHINE SCREW	20	20	20	22	25
DOOR	12-24 x 3/4" PHILLIPS FLAT HEAD, UNDERCUT, SELF DRILLING, THREAD FORMING TEK MACHINE SCREW	20	20	20	22	25

A110HD-EA & R, ELECTRICAL MODIFICATION WITH REMOVABLE OPTION-1-02.DWG



www.abhmfg.com
E-mail: abhinfo@abhmfg.com
Architectural Builders Hardware Mfg., Inc.
1222 Ardmore Ave., Itasca, IL 60143
630.875.9900; FAX 800.9FAXABH (932.9224)

© 2020 ABH Mfg., Inc.
printed in USA

A110HD - "EA" & "R"
ELECTRICAL MODIFICATION
WITH REMOVABLE OPTION

PAGE 1 OF 2
REVISED 09-23-20

A110HD - "EA" & "R" ELECTRICAL MODIFICATION WITH REMOVABLE OPTION

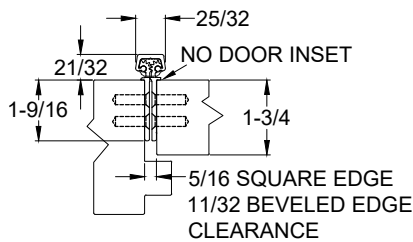
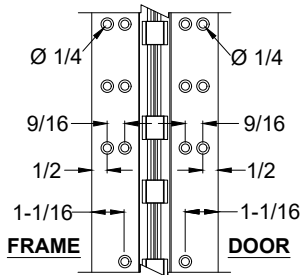

CLOSED POSITION

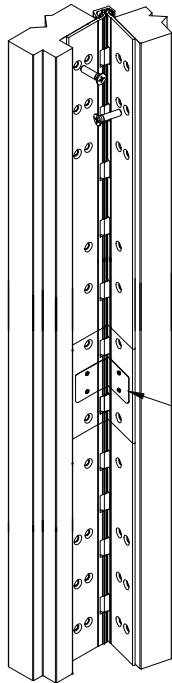

**ISOMETRIC VIEW
~90° OPENING**

#6 SPANNER FLAT HEAD SECURITY SCREW PROVIDED STANDARD (4 PLACES)

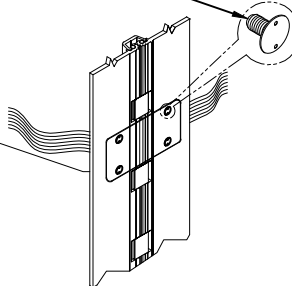

**ISOMETRIC VIEW
180° OPENING**

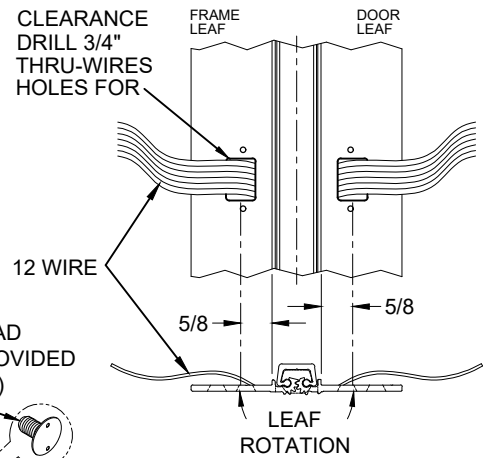

WIRE TRANSFER VIEW

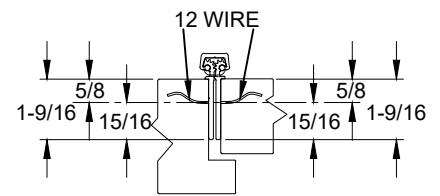

WIRE TRANSFER VIEW

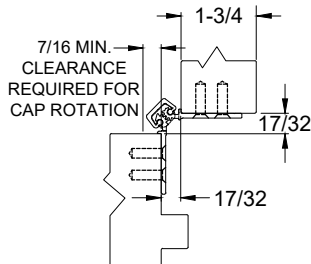

90° OPENING

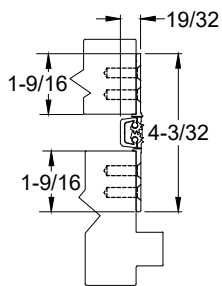

180° OPENING

NOTES:

1. MOLEX CONNECTOR OPTION AVAILABLE - SUFFIX "EZ".

* SPECIFY ELECTRIFIED HARDWARE MANUFACTURER FOR CONNECTOR COMPABILITY

EZ CONNECT OPTION

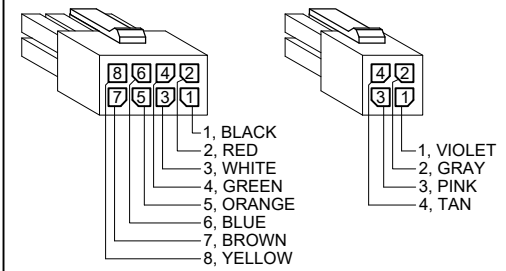

SPECIFICATION:

DESCRIPTION: SINGLE CONDUCTOR #22 AWG MINIATURE HOOK-UP WIRE FOR APPLICATIONS REQUIRING EXTREME FLEXIBILITY.

CONDUCTOR: #22 AWG 168/44 (0.002") SOFT BARE COPPER LHL.

INSULATION: PROPRIETARY FORMULATION PVC 0.010" NOM. WALL MEETS VW-1 FLAME REQUIREMENT.

DIAMETER: 0.053" ± 0.003".

RESISTANCE: 16.7 OHMS MAX. @ 20°C, PER 1000 FT.

VOLTAGE RATING: 600 VOLTS RMS, DEPENDING ON SPECIFICATION.

AVAILABLE AS RoHS COMPLIANT.

A110HD-EA & R, ELECTRICAL MODIFICATION WITH REMOVABLE OPTION-2-02.DWG



www.abhmfg.com
E-mail: abhinfo@abhmfg.com
Architectural Builders Hardware Mfg., Inc.
1222 Ardmore Ave., Itasca, IL 60143
630.875.9900; FAX 800.9FAXABH (932.9224)

© 2020 ABH Mfg., Inc.
printed in USA

A110HD - "EA" & "R"
ELECTRICAL MODIFICATION
WITH REMOVABLE OPTION

PAGE 2 OF 2
REVISED 09-23-20

A110HD / A110LL - "AHT" OPTION, ADVANCED HOSPITAL TIP, ALUMINUM GEARED HINGE, FLUSH MOUNT, FULL CONCEALED

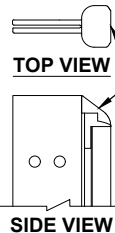
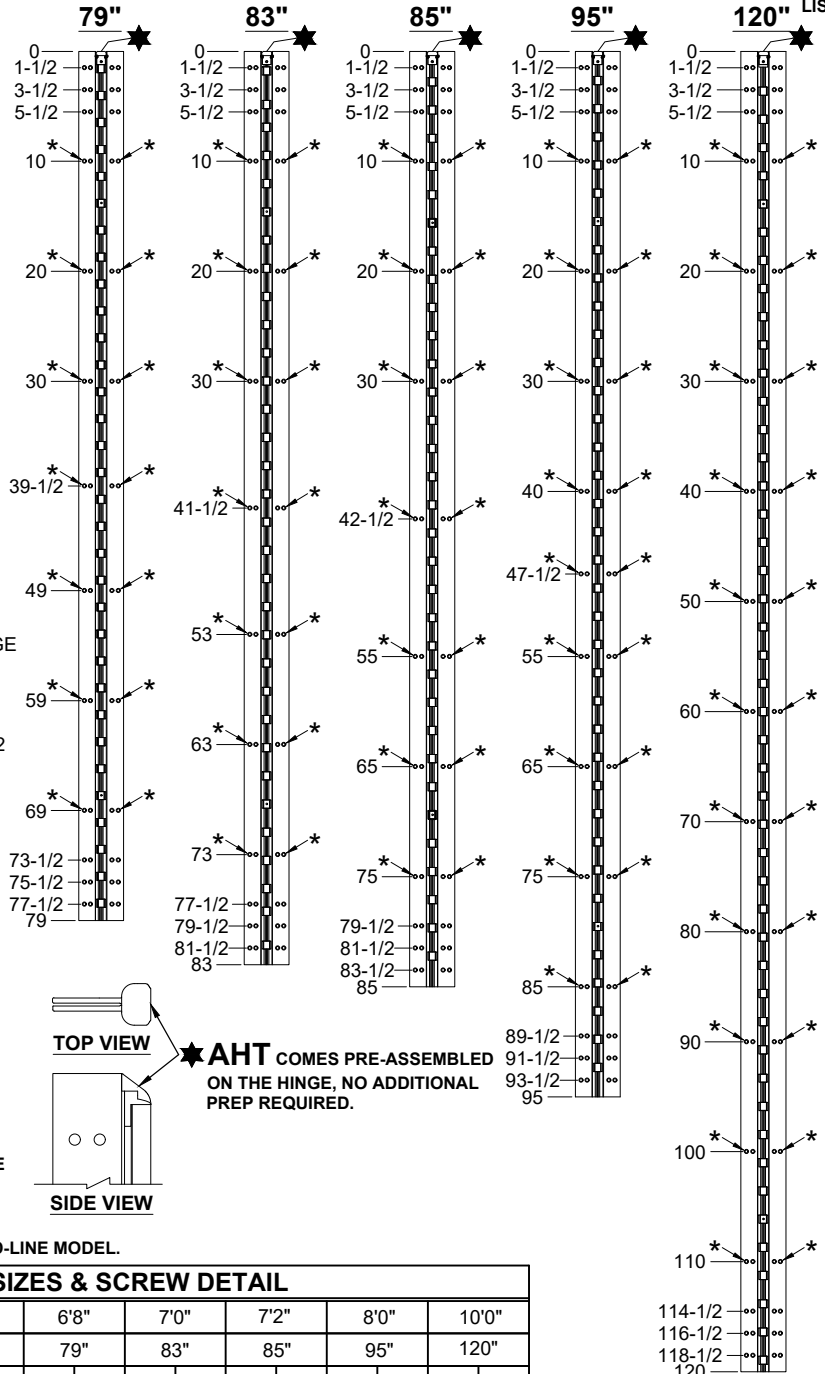
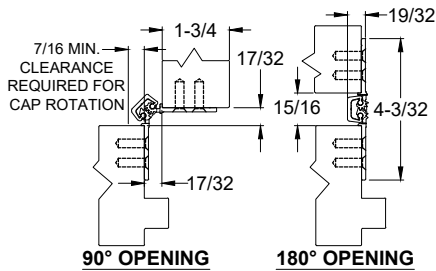
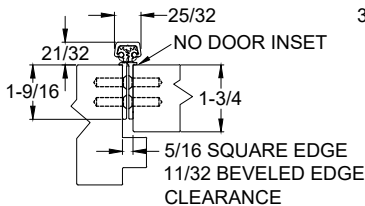
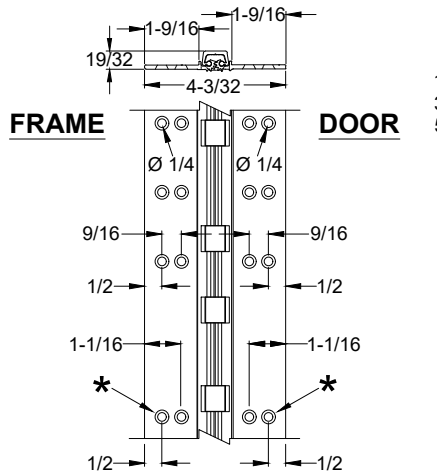

AHT COMES PRE-ASSEMBLED ON THE HINGE, NO ADDITIONAL PREP REQUIRED.

- NOTES:**
1. HINGES CUT TO CUSTOM LENGTH ARE CUT FROM THE BOTTOM. PLEASE SPECIFY HANDING.
 2. ALL DIMENSIONS ARE IN INCHES.
 3. ALL DIMENSIONS ARE TO CENTERLINE OF HOLES.
 4. * = DENOTES EXTRA MOUNTING HOLE FOR THE LEAD-LINE MODEL.

STANDARD HINGE SIZES & SCREW DETAIL											
NOMINAL DOOR HEIGHT		6'8"		7'0"		7'2"		8'0"		10'0"	
ACTUAL HINGE LENGTH		79"		83"		85"		95"		120"	
		HD	LL	HD	LL	HD	LL	HD	LL	HD	LL
FRAME	12-24 x 3/4" PHILLIPS FLAT HEAD, UNDERCUT, SELF DRILLING, THREAD FORMING TEK MACHINE SCREW	19	26	19	26	19	26	21	30	23	34
DOOR	12-24 x 3/4" PHILLIPS FLAT HEAD, UNDERCUT, SELF DRILLING, THREAD FORMING TEK MACHINE SCREW	19	26	19	26	19	26	21	30	23	34



www.abhmfg.com
 E-mail: abhinfo@abhmfg.com
 Architectural Builders Hardware Mfg., Inc.
 1222 Ardmore Ave., Itasca, IL 60143
 630.875.9900; FAX 800.9FAXABH (932.9224)

A110-AHT OPTION, ADVANCED HOSPITAL TIP-01.DWG

A110 - "AHT" OPTION
 ADVANCED HOSPITAL TIP
 PAGE 1 OF 1
 REVISED 10-28-20

© 2020 ABH Mfg., Inc.
 printed in USA

**A110HD - "EM" OPTION, CONCEALED ELECTRIFICATION, FULL CONCEALED,
ALUMINUM GEARED HINGE**

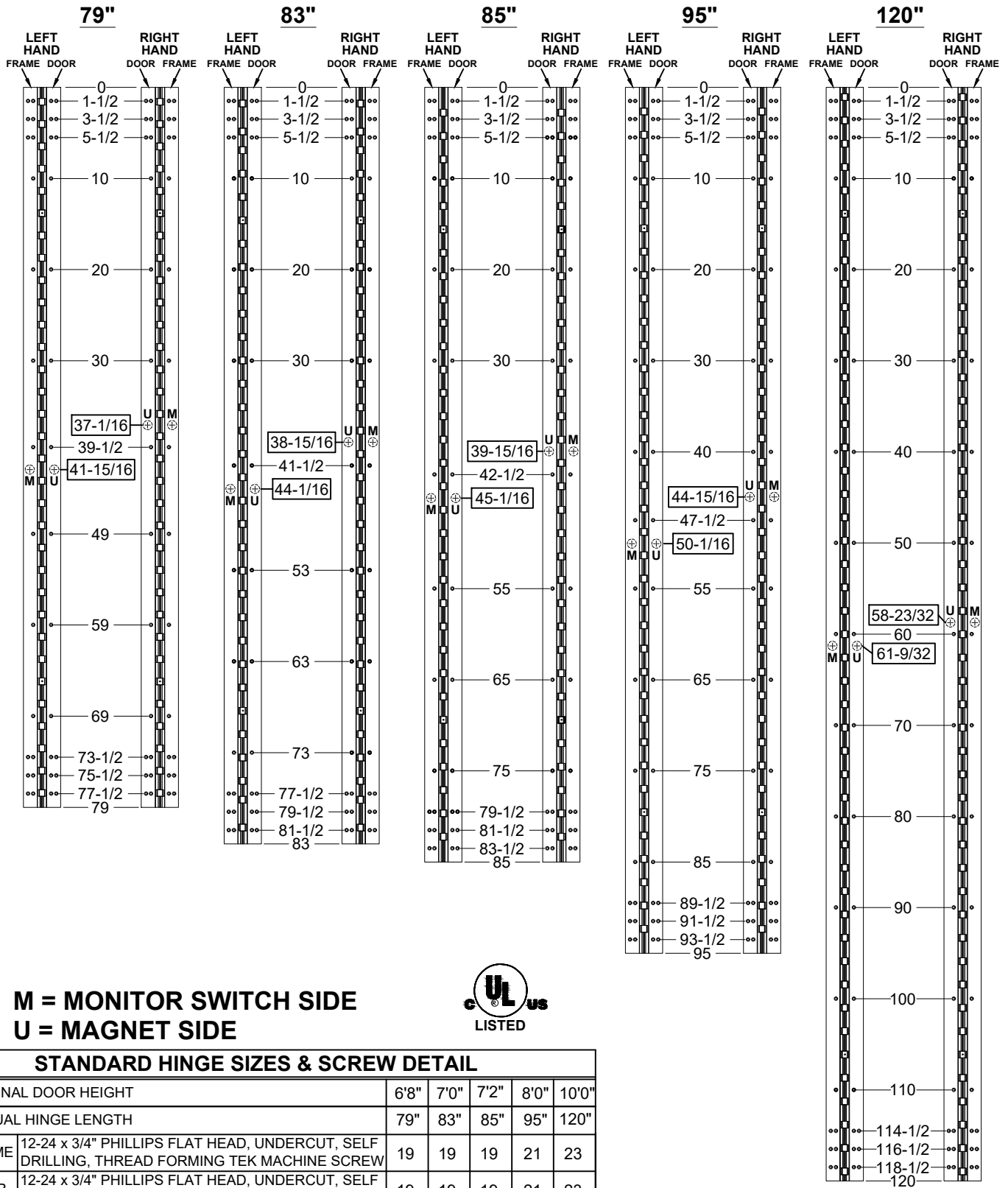

M = MONITOR SWITCH SIDE
U = MAGNET SIDE



STANDARD HINGE SIZES & SCREW DETAIL

NOMINAL DOOR HEIGHT	6'8"	7'0"	7'2"	8'0"	10'0"
ACTUAL HINGE LENGTH	79"	83"	85"	95"	120"
FRAME	12-24 x 3/4" PHILLIPS FLAT HEAD, UNDERCUT, SELF DRILLING, THREAD FORMING TEK MACHINE SCREW				
	19	19	19	21	23
DOOR	12-24 x 3/4" PHILLIPS FLAT HEAD, UNDERCUT, SELF DRILLING, THREAD FORMING TEK MACHINE SCREW				
	19	19	19	21	23

A110HD-EM OPTION, CONCEALED ELECTRIFICATION-1-02.DWG



www.abhmf.com
E-mail: abhinfo@abhmf.com
Architectural Builders Hardware Mfg., Inc.
1222 Ardmore Ave., Itasca, IL 60143
630.875.9900; FAX 800.9FAXABH (932.9224)

© 2020 ABH Mfg., Inc.
printed in USA

**A110HD - "EM" OPTION
CONCEALED ELECTRIFICATION**

PAGE 1 OF 2
REVISED 9-23-20

**A110HD - "EM" OPTION, CONCEALED ELECTRIFICATION, FULL CONCEALED,
ALUMINUM GEARED HINGE**

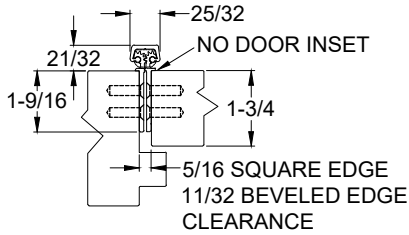

CLOSED POSITION

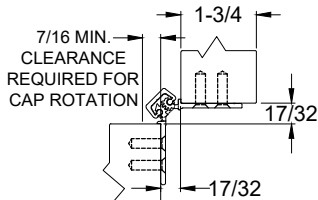

90° OPENING

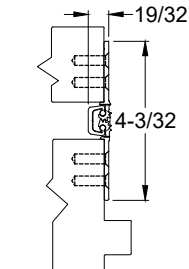

180° OPENING

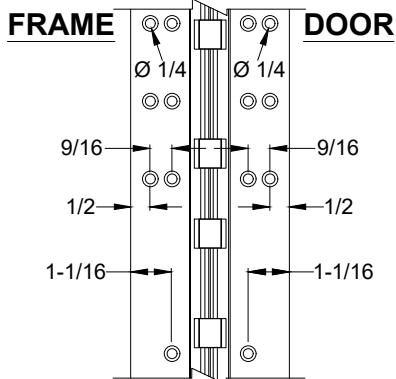
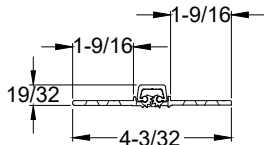

NOTES:

1. HINGES CUT TO CUSTOM LENGTH ARE CUT FROM BOTTOM OF HINGE.
2. SPECIFY HANDING WHEN ORDERING.
3. IF "M" OPTION (MOVEABLE PANEL) OR "R" OPTION (REMOVABLE PANEL) IS CHOSEN, TEMPLATE REMAINS THE SAME.

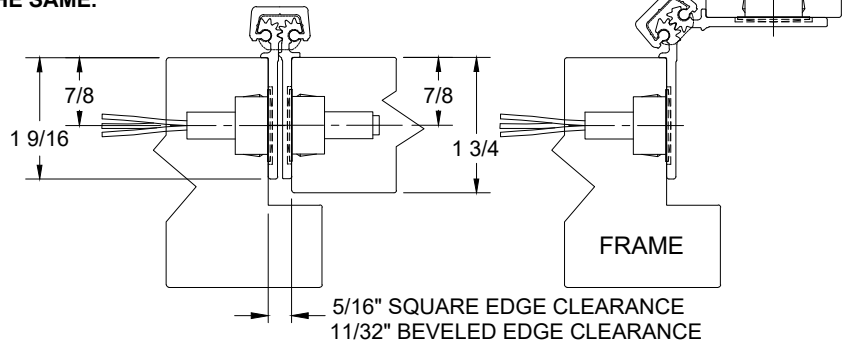

**MAGNETIC MONITOR SWITCH VIEW,
LEFT HAND SHOWN**

NOTE: 7/8" DIA. MIN. CLEARANCE HOLE REQUIRED IN DOOR & FRAME FOR MONITORING SWITCH AND MAGNET

ELECTRICAL CONFIG.: SPDT
MAX. INITIAL CONTACT RESISTANCE : 0.140 OHM
MAX. CONTACT RATING: 5 WATT
MAX. SWITCHING VOLTAGE: 175 VDC
MAX. SWITCHING CURRENT: 0.25 AMP

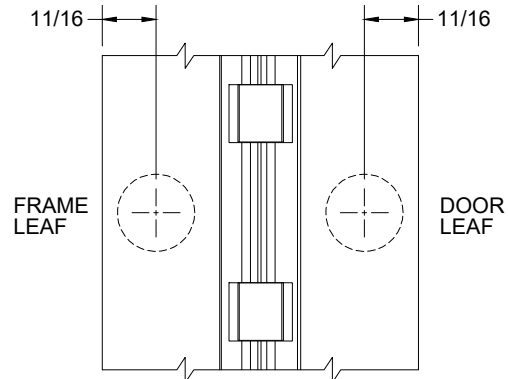
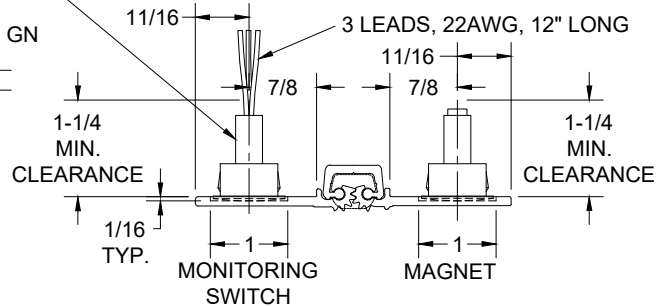
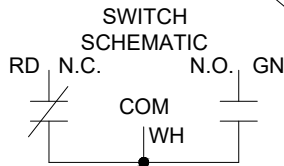

MAGNETIC MONITOR SWITCH VIEW

A110HD-EM OPTION, CONCEALED ELECTRIFICATION-2-02.DWG

**A110HD - "ES" OPTION, CONCEALED ELECTRIFICATION, FULL CONCEALED,
ALUMINUM GEARED HINGE**

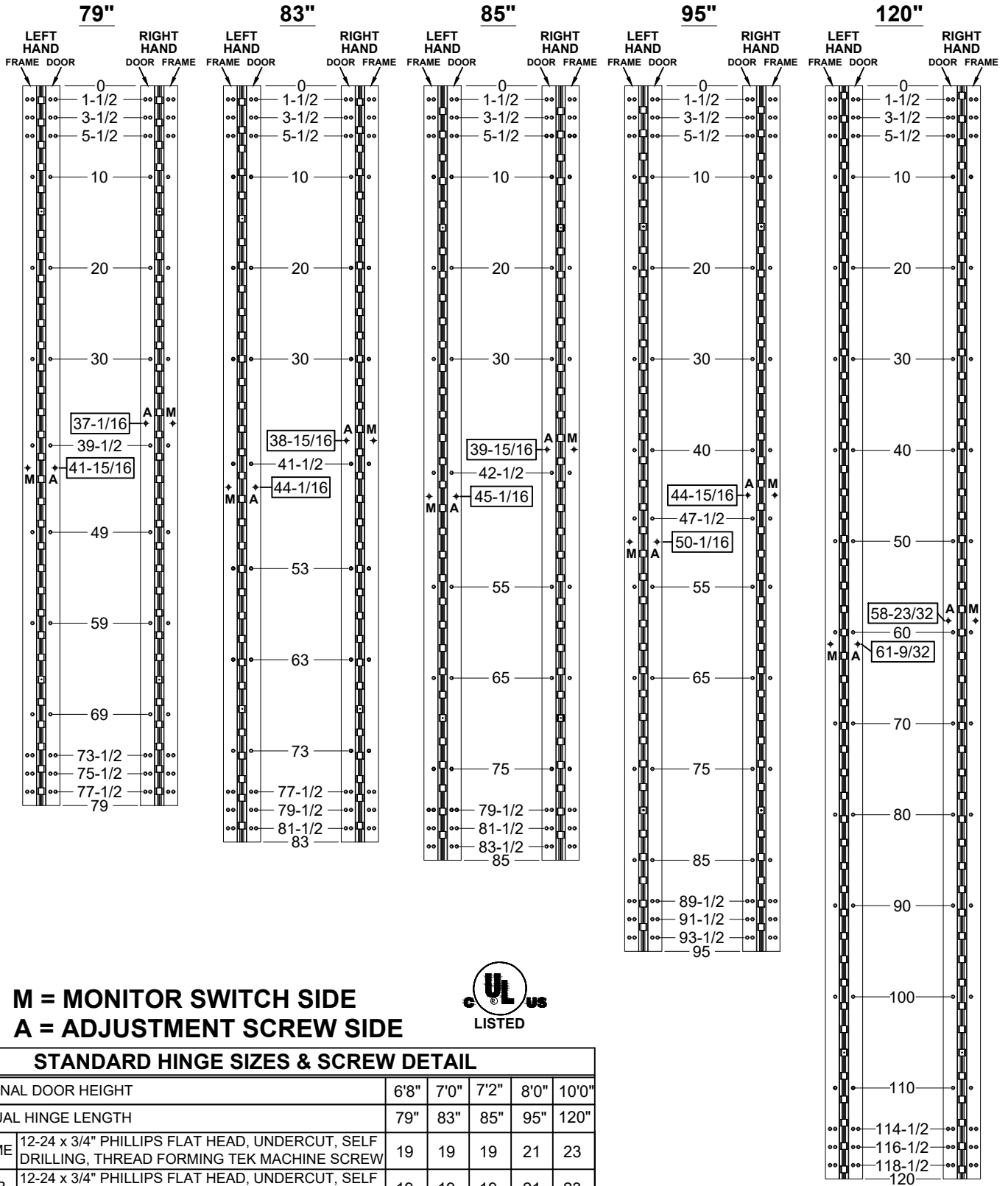

M = MONITOR SWITCH SIDE
A = ADJUSTMENT SCREW SIDE



STANDARD HINGE SIZES & SCREW DETAIL

		6'8"	7'0"	7'2"	8'0"	10'0"
NOMINAL DOOR HEIGHT		6'8"	7'0"	7'2"	8'0"	10'0"
ACTUAL HINGE LENGTH		79"	83"	85"	95"	120"
FRAME	12-24 x 3/4" PHILLIPS FLAT HEAD, UNDERCUT, SELF DRILLING, THREAD FORMING TEK MACHINE SCREW	19	19	19	21	23
DOOR	12-24 x 3/4" PHILLIPS FLAT HEAD, UNDERCUT, SELF DRILLING, THREAD FORMING TEK MACHINE SCREW	19	19	19	21	23

A110HD-ES OPTION, CONCEALED ELECTRIFICATION-1-02.DWG



www.abhmfg.com
E-mail: abhinfo@abhmfg.com
Architectural Builders Hardware Mfg., Inc.
1222 Ardmore Ave., Itasca, IL 60143
630.875.9900; FAX 800.9FAXABH (932.9224)

© 2020 ABH Mfg., Inc.
printed in USA

**A110HD - "ES" OPTION
CONCEALED ELECTRIFICATION**

PAGE 1 OF 2
REVISED 9-23-20

**A110HD - "ES" OPTION, CONCEALED ELECTRIFICATION, FULL CONCEALED,
ALUMINUM GEARED HINGE**

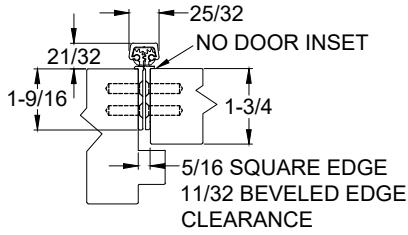

CLOSED POSITION

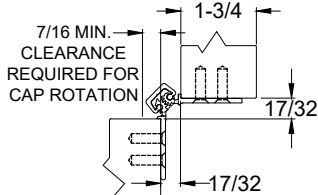

90° OPENING

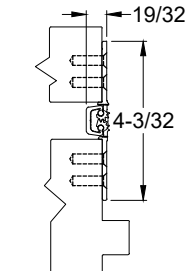

180° OPENING

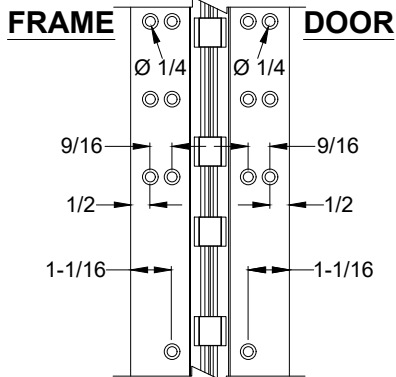
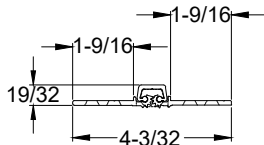

NOTES:

1. HINGES CUT TO CUSTOM LENGTH ARE CUT FROM BOTTOM OF HINGE.
2. SPECIFY HANDING WHEN ORDERING.
3. IF "M" OPTION (MOVEABLE PANEL) OR "R" OPTION (REMOVABLE PANEL) IS CHOSEN, TEMPLATE REMAINS THE SAME.

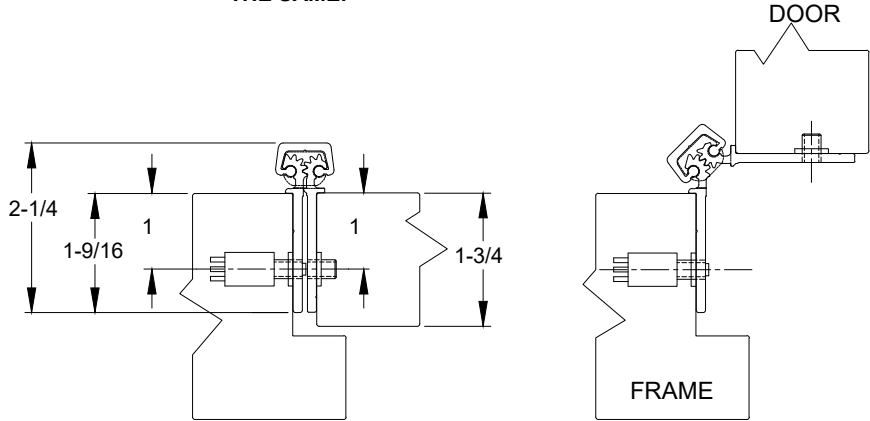

EXPOSED MONITOR SWITCH VIEW, LEFT HAND SHOWN

SWITCH SCHEMATIC

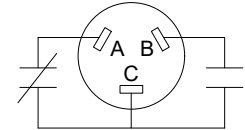

A & C = NORMALLY CLOSED
B & C = NORMALLY OPEN

NOTE: 5/8" DIA. HOLE REQUIRED IN JAMB FOR MONITORING SWITCH AND A 7/16" DIA. HOLE FOR CLEARANCE OF ADJUSTMENT SCREW

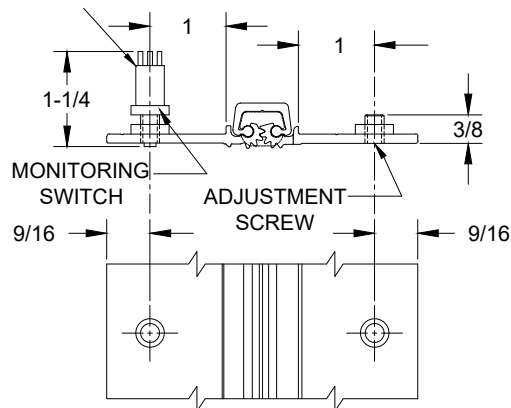

EXPOSED MONITOR SWITCH VIEW

A110HD-ES OPTION, CONCEALED ELECTRIFICATION-2-02.DWG

**A110HDSL / A110LLSL - ALUMINUM GEARED HINGE, FLUSH MOUNT, FULL CONCEALED
FOR 1-3/8" THICK DOOR**

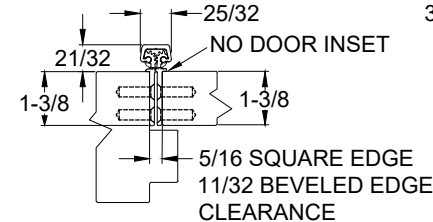
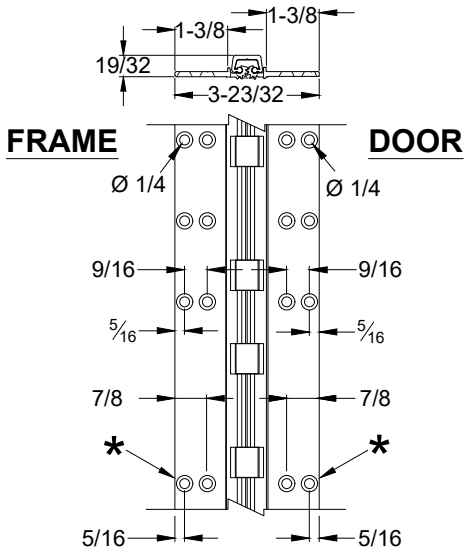

CLOSED POSITION

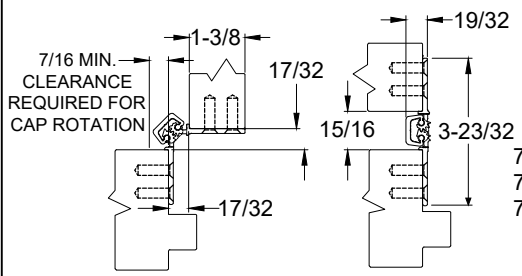

90° OPENING 180° OPENING

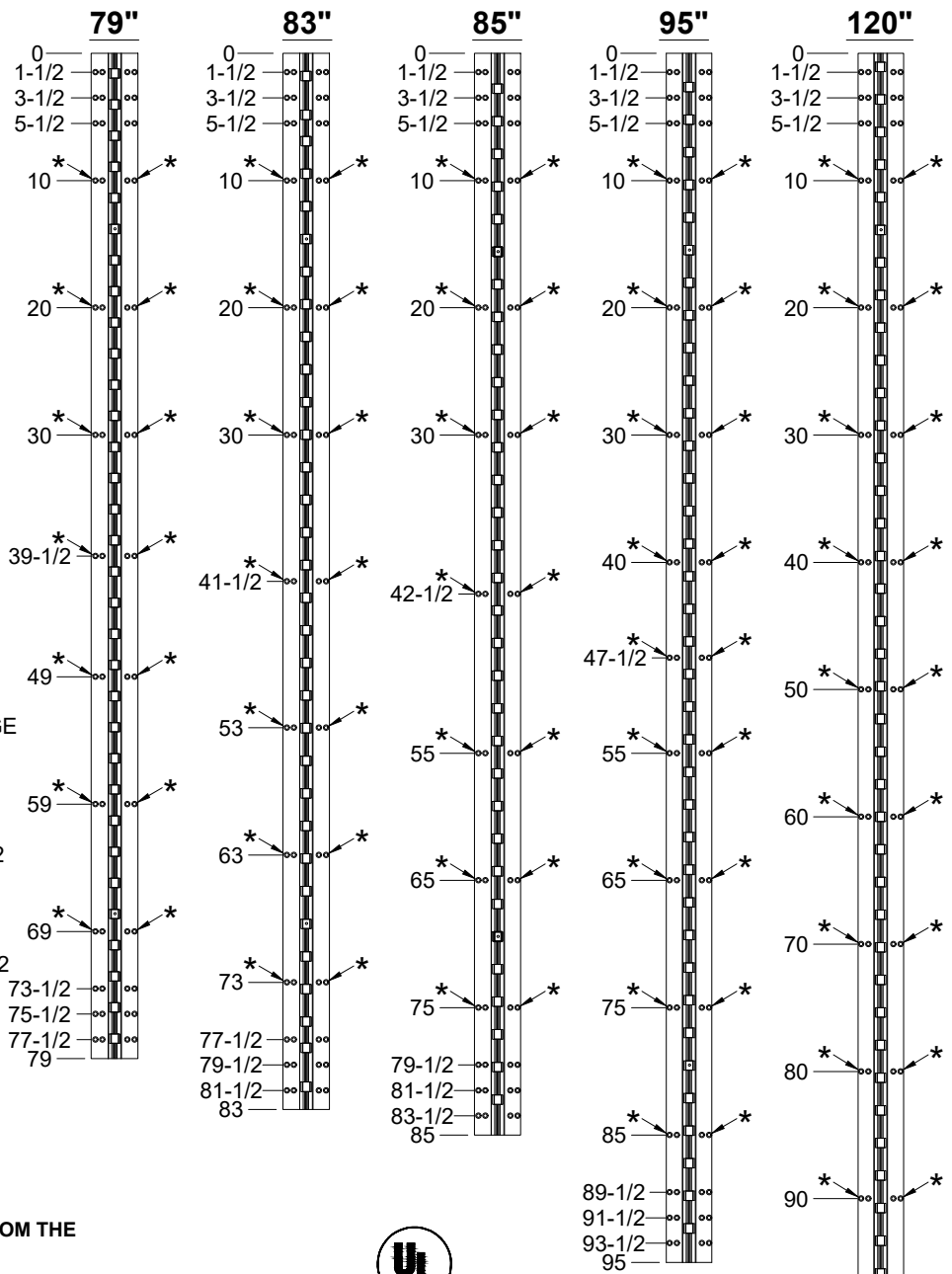

NOTES:

1. HINGES CUT TO CUSTOM LENGTH ARE CUT FROM THE BOTTOM. PLEASE SPECIFY HANDING.
2. ALL DIMENSIONS ARE IN INCHES.
3. ALL DIMENSIONS ARE TO CENTERLINE OF HOLES.
4. * = DENOTES EXTRA MOUNTING HOLE FOR THE LEAD-LINE MODEL.



STANDARD HINGE SIZES & SCREW DETAIL

NOMINAL DOOR HEIGHT		6'8"		7'0"		7'2"		8'0"		10'0"	
ACTUAL HINGE LENGTH		79"		83"		85"		95"		120"	
		HD	LL	HD	LL	HD	LL	HD	LL	HD	LL
FRAME	12-24 x 3/4" PHILLIPS FLAT HEAD, UNDERCUT, SELF DRILLING, THREAD FORMING TEK MACHINE SCREW	19	26	19	26	19	26	21	30	23	34
DOOR	12-24 x 3/4" PHILLIPS FLAT HEAD, UNDERCUT, SELF DRILLING, THREAD FORMING TEK MACHINE SCREW	19	26	19	26	19	26	21	30	23	34



www.abhmfg.com
 E-mail: abhinfo@abhmfg.com
 Architectural Builders Hardware Mfg., Inc.
 1222 Ardmore Ave., Itasca, IL 60143
 630.875.9900; FAX 800.9FAXABH (932.9224)

**A110HD-SL
ALUMINUM GEARED HINGE**

© 2020 ABH Mfg., Inc.
 printed in USA

A110HD-SL-ALUMINUM GEARED HINGE-02.DWG

POWDER COAT MASKING

**MUST HANG PART
AS SHOWN TO PREVENT
PART FROM BENDING
BY THE CUTOUT**

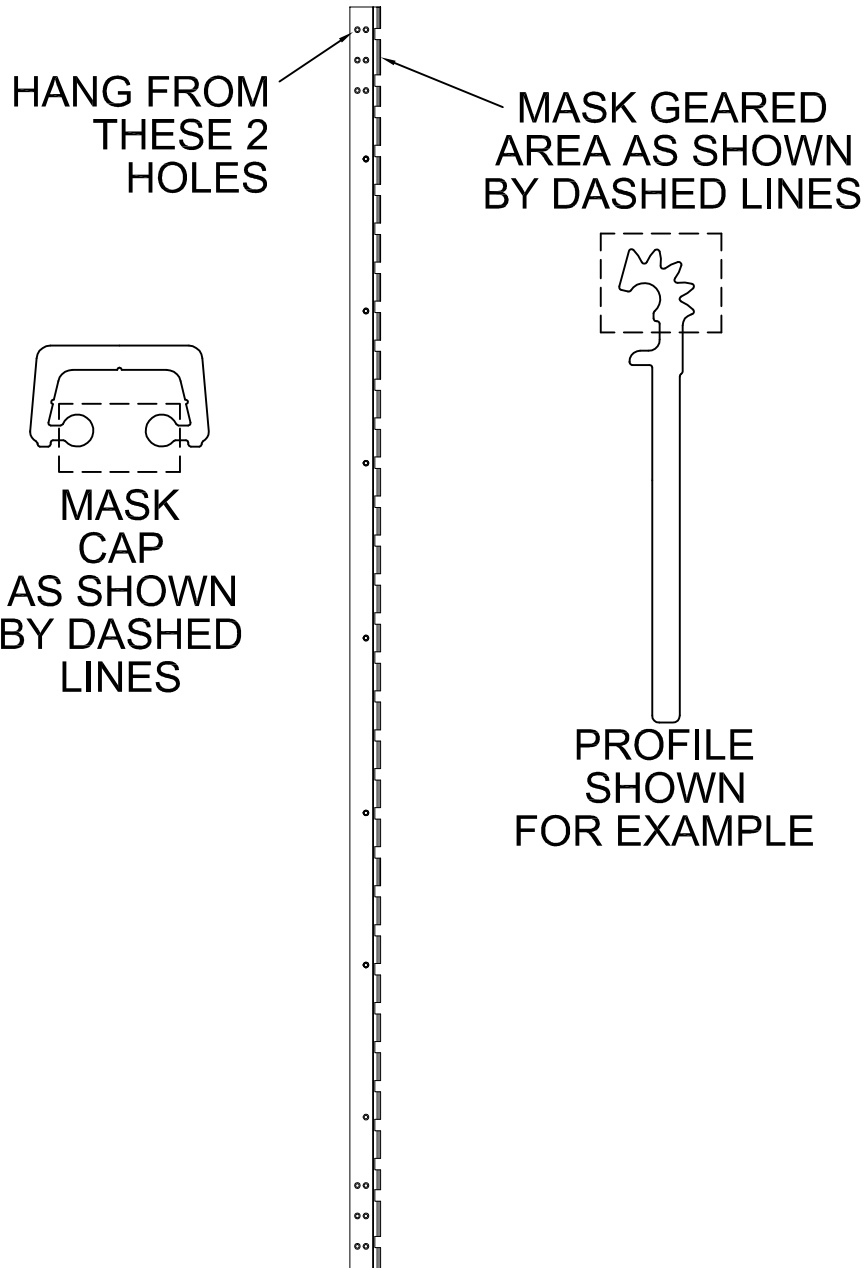

® www.abhmfg.com
E-mail: abhinfo@abhmfg.com
Architectural Builders Hardware Mfg., Inc.
1222 Ardmore Ave., Itasca, IL 60143
630.875.9900; FAX 800.9FAXABH (932.9224)

POWDER COAT MASKING-00.DWG

POWDER COAT MASKING

© 2008 ABH Mfg., Inc.
printed in USA

PAGE 1 OF 1
ISSUED 12-15-08