

## Full Concealed

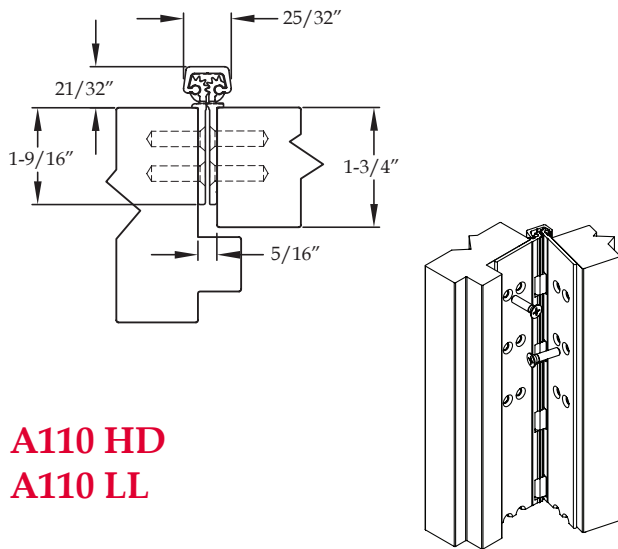

### A110 HD A110 LL

#### Standard Features

- Full concealed, heavy duty
- No door inset, flush mount
- 48" door width maximum
- 450 lbs. door weight maximum
- "LL" model for doors up to 1,000 lbs. (lead-lined staggered hole pattern)
- **Fasteners:** 12-24 x 7/8" undercut self-drilling, thread-forming tek machine screws
- **Standard lengths:** 79", 83", 85", 95" and 120"
- **Finishes:** Clear, dark bronze and black anodized
- **Fire Rating**
  - Approved for use on metal swinging type fire doors rated up to and including 90 minutes (Specify "FR" option for 3 hour rating)
  - Approved for use on wood swinging type fire doors rated up to and including 60 minutes (Specify "FR" option for 90 minute rating)

#### Options Available

- See pages F-7 to F-8 for option availability and details

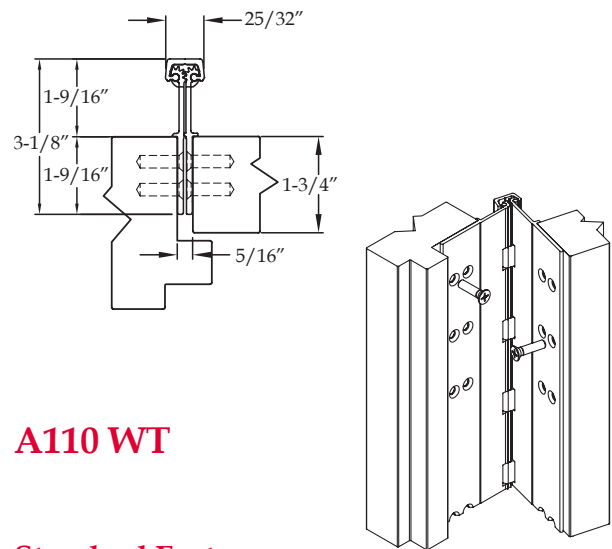

### A110 WT

#### Standard Features

- Full concealed, heavy duty
- No door inset, flush mount
- Wide throw for applications that need extra clearance for the door or the frame
- 48" door width maximum
- 450 lbs. door weight maximum
- **Fasteners:** 12-24 x 7/8" undercut self-drilling, thread-forming tek machine screws
- **Standard lengths:** 79", 83", 85", 95" and 120"
- **Finishes:** Clear, dark bronze and black anodized
- **Fire Rating**
  - Approved for use on metal swinging type fire doors rated up to and including 90 minutes (Specify "FR" option for 3 hour rating)
  - Approved for use on wood swinging type fire doors rated up to and including 60 minutes (Specify "FR" option for 90 minute rating)

#### Options Available

- See pages F-7 to F-8 for option availability and details



# A110HD / A110LL - ALUMINUM GEARED HINGE, FLUSH MOUNT, FULL CONCEALED

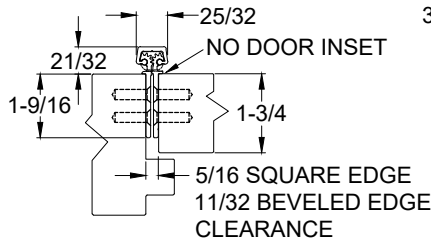
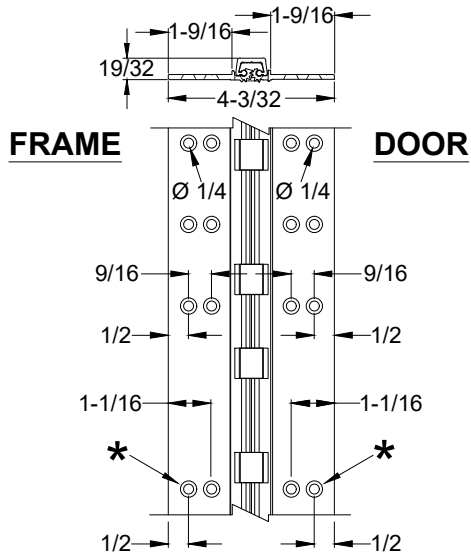

**CLOSED POSITION**

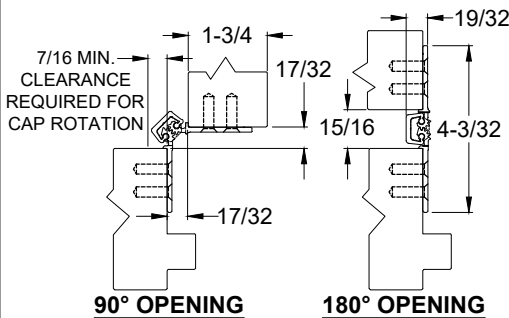

**90° OPENING**

**180° OPENING**

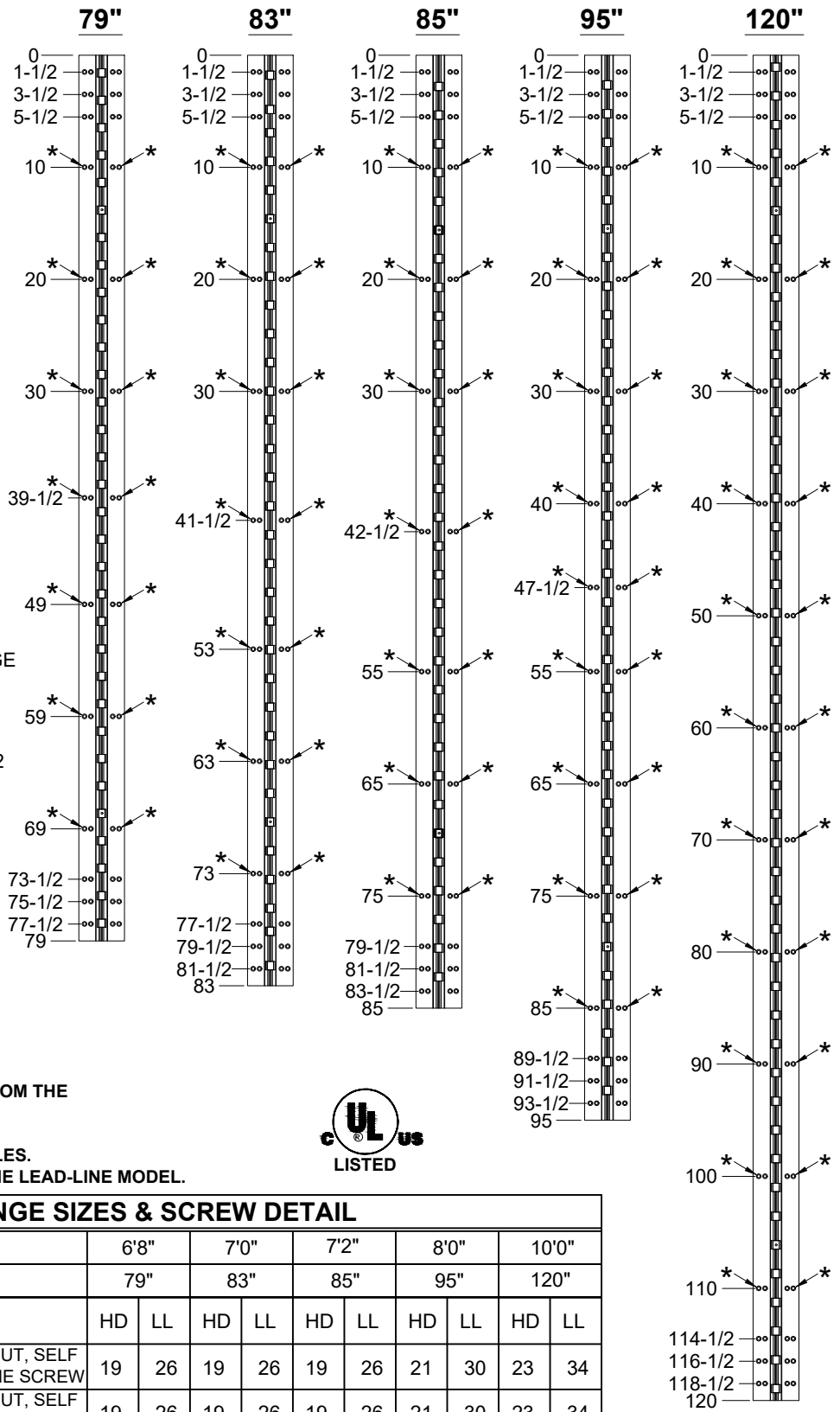

**NOTES:**

1. HINGES CUT TO CUSTOM LENGTH ARE CUT FROM THE BOTTOM. PLEASE SPECIFY HANDING.
2. ALL DIMENSIONS ARE IN INCHES.
3. ALL DIMENSIONS ARE TO CENTERLINE OF HOLES.
4. \* = DENOTES EXTRA MOUNTING HOLE FOR THE LEAD-LINE MODEL.



**STANDARD HINGE SIZES & SCREW DETAIL**

NOMINAL DOOR HEIGHT		6'8"		7'0"		7'2"		8'0"		10'0"	
ACTUAL HINGE LENGTH		79"		83"		85"		95"		120"	
		HD	LL	HD	LL	HD	LL	HD	LL	HD	LL
FRAME	12-24 x 3/4" PHILLIPS FLAT HEAD, UNDERCUT, SELF DRILLING, THREAD FORMING TEK MACHINE SCREW	19	26	19	26	19	26	21	30	23	34
DOOR	12-24 x 3/4" PHILLIPS FLAT HEAD, UNDERCUT, SELF DRILLING, THREAD FORMING TEK MACHINE SCREW	19	26	19	26	19	26	21	30	23	34



www.abhmfg.com  
 E-mail: abhinfo@abhmfg.com  
 Architectural Builders Hardware Mfg., Inc.  
 1222 Ardmore Ave., Itasca, IL 60143  
 630.875.9900; FAX 800.9FAXABH (932.9224)

© 2020 ABH Mfg., Inc.  
 printed in USA

**A110**  
 ALUMINUM GEARED HINGE

PAGE 1 OF 1  
 REVISED 8-21-20

A110-ALUMINUM GEARED HINGE-02.DWG

**A110HD / A110LL - "AHT" OPTION, ADVANCED HOSPITAL TIP, ALUMINUM GEARED HINGE, FLUSH MOUNT, FULL CONCEALED**

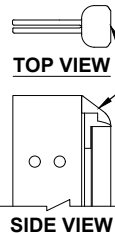
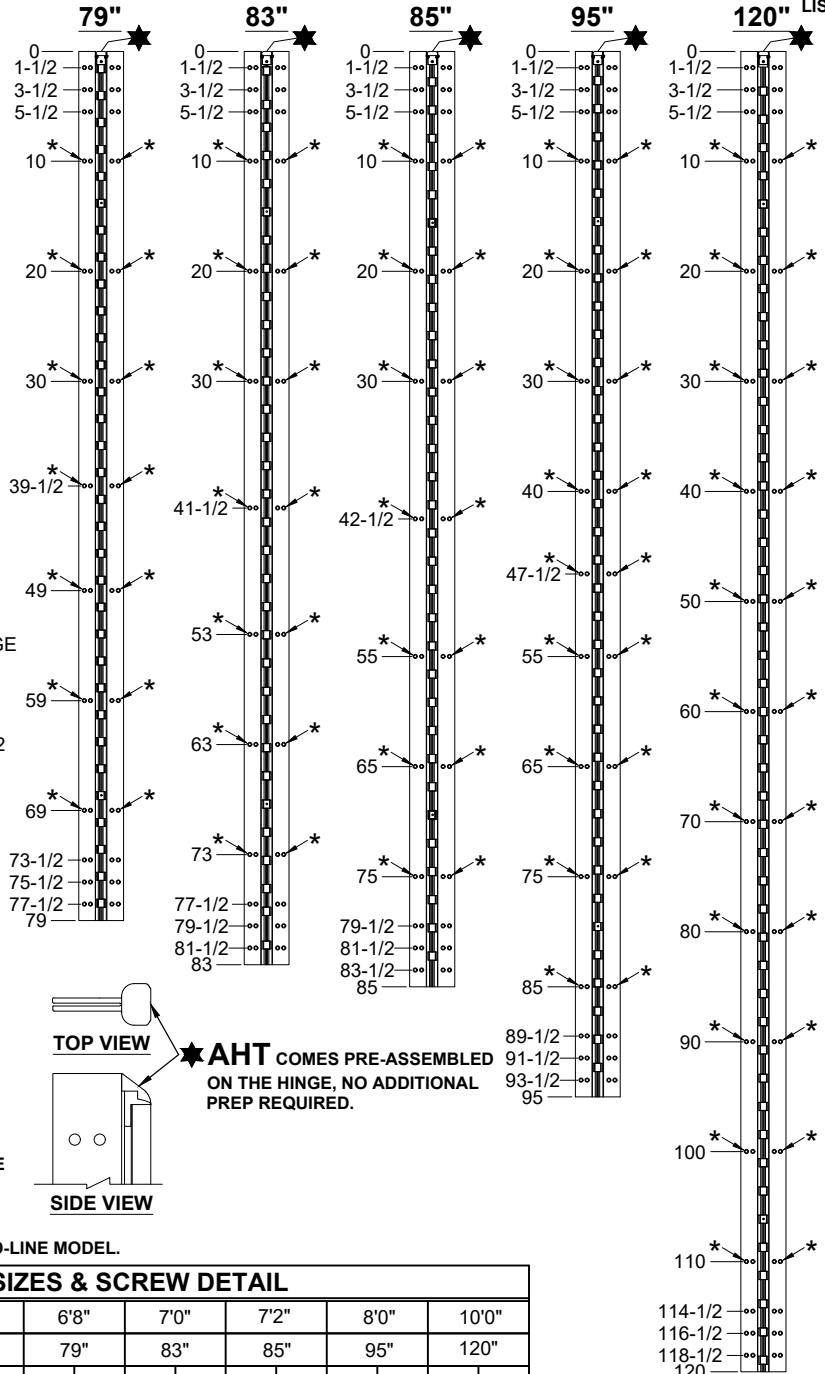
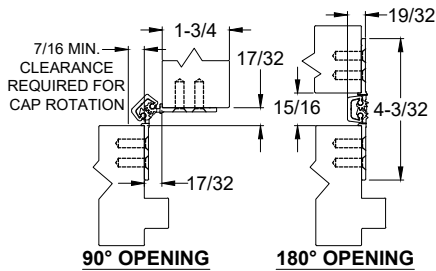
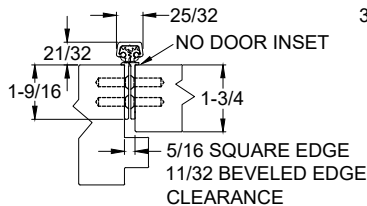
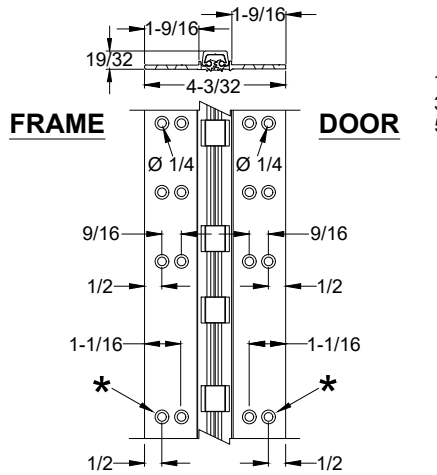

**AHT** COMES PRE-ASSEMBLED ON THE HINGE, NO ADDITIONAL PREP REQUIRED.

**NOTES:**

1. HINGES CUT TO CUSTOM LENGTH ARE CUT FROM THE BOTTOM. PLEASE SPECIFY HANDING.
2. ALL DIMENSIONS ARE IN INCHES.
3. ALL DIMENSIONS ARE TO CENTERLINE OF HOLES.
4. \* = DENOTES EXTRA MOUNTING HOLE FOR THE LEAD-LINE MODEL.

**STANDARD HINGE SIZES & SCREW DETAIL**

NOMINAL DOOR HEIGHT	6'8"	7'0"	7'2"	8'0"	10'0"							
ACTUAL HINGE LENGTH	79"	83"	85"	95"	120"							
	HD	LL	HD	LL	HD	LL	HD	LL	HD	LL		
FRAME	12-24 x 3/4" PHILLIPS FLAT HEAD, UNDERCUT, SELF DRILLING, THREAD FORMING TEK MACHINE SCREW		19	26	19	26	19	26	21	30	23	34
DOOR	12-24 x 3/4" PHILLIPS FLAT HEAD, UNDERCUT, SELF DRILLING, THREAD FORMING TEK MACHINE SCREW		19	26	19	26	19	26	21	30	23	34



www.abhmfg.com  
 E-mail: abhinfo@abhmfg.com  
 Architectural Builders Hardware Mfg., Inc.  
 1222 Ardmore Ave., Itasca, IL 60143  
 630.875.9900; FAX 800.9FAXABH (932.9224)

A110-AHT OPTION, ADVANCED HOSPITAL TIP-01.DWG

**A110 - "AHT" OPTION**  
 ADVANCED HOSPITAL TIP

© 2020 ABH Mfg., Inc.  
 printed in USA

PAGE 1 OF 1  
 REVISED 10-28-20

**A110HDSL / A110LLSL - ALUMINUM GEARED HINGE, FLUSH MOUNT, FULL CONCEALED  
FOR 1-3/8" THICK DOOR**

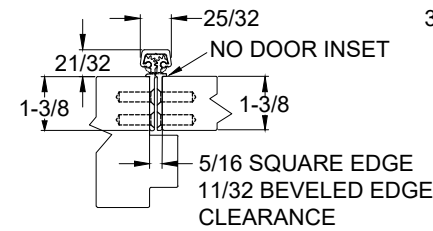
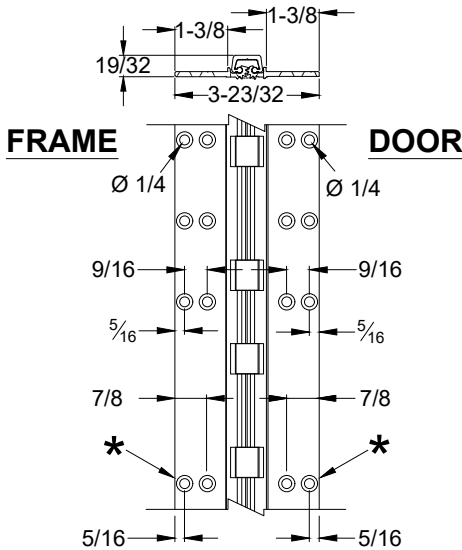

**CLOSED POSITION**

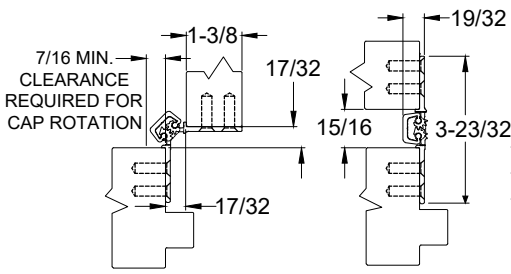

**90° OPENING      180° OPENING**

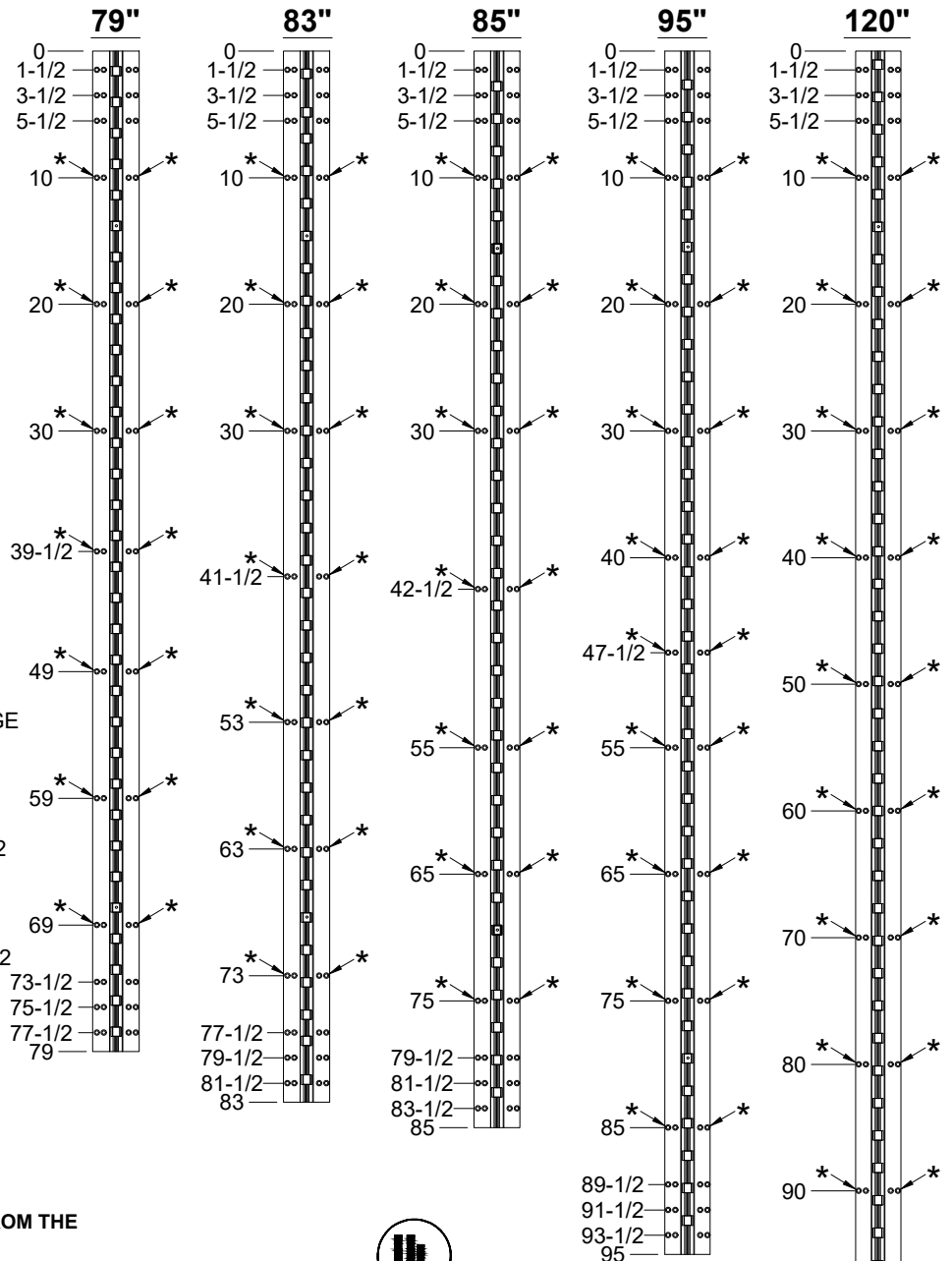

**NOTES:**

1. HINGES CUT TO CUSTOM LENGTH ARE CUT FROM THE BOTTOM. PLEASE SPECIFY HANDING.
2. ALL DIMENSIONS ARE IN INCHES.
3. ALL DIMENSIONS ARE TO CENTERLINE OF HOLES.
4. \* = DENOTES EXTRA MOUNTING HOLE FOR THE LEAD-LINE MODEL.



**STANDARD HINGE SIZES & SCREW DETAIL**

NOMINAL DOOR HEIGHT		6'8"		7'0"		7'2"		8'0"		10'0"	
ACTUAL HINGE LENGTH		79"		83"		85"		95"		120"	
		HD	LL	HD	LL	HD	LL	HD	LL	HD	LL
FRAME	12-24 x 3/4" PHILLIPS FLAT HEAD, UNDERCUT, SELF DRILLING, THREAD FORMING TEK MACHINE SCREW	19	26	19	26	19	26	21	30	23	34
DOOR	12-24 x 3/4" PHILLIPS FLAT HEAD, UNDERCUT, SELF DRILLING, THREAD FORMING TEK MACHINE SCREW	19	26	19	26	19	26	21	30	23	34

A110HD-SL-ALUMINUM GEARED HINGE-02.DWG



www.abhmfg.com  
E-mail: abhinfo@abhmfg.com  
Architectural Builders Hardware Mfg., Inc.  
1222 Ardmore Ave., Itasca, IL 60143  
630.875.9900; FAX 800.9FAXABH (932.9224)

© 2020 ABH Mfg., Inc.  
printed in USA

**A110HD-SL  
ALUMINUM GEARED HINGE**

**A110HD/LL - "EA" OPTION, EASY ACCESS CONCEALED ELECTRIFICATION,  
ALUMINUM GEARED HINGE**

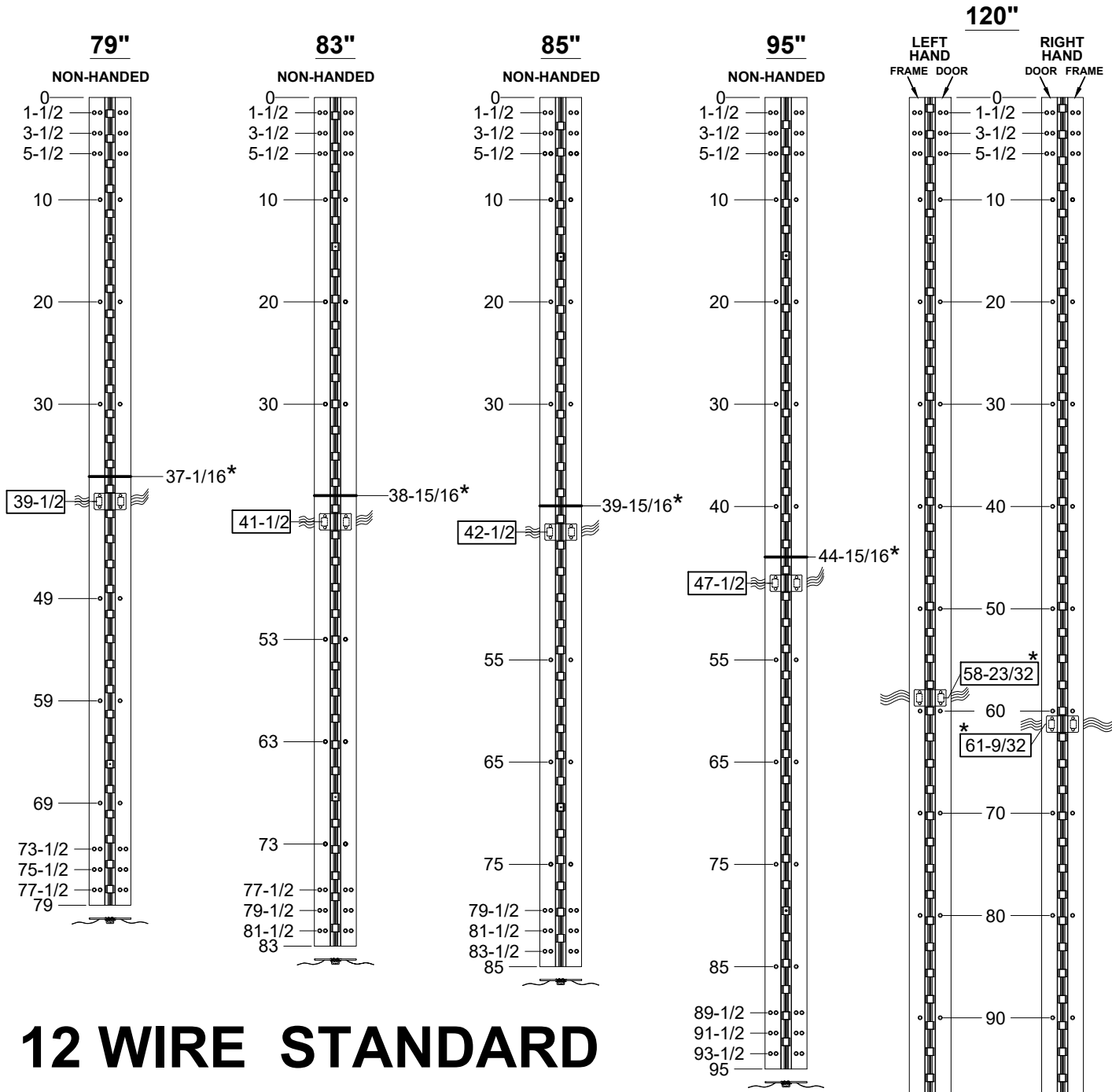

# 12 WIRE STANDARD

**NOTES:**

1. HINGES CUT TO CUSTOM LENGTH ARE CUT FROM BOTTOM OF HINGE. CUSTOM CUT HINGE REQUIRES HANDING.



   = STANDARD LOCATION

\* = LL (LEAD LINED) OPTION LOCATION

**STANDARD HINGE SIZES & SCREW DETAIL**

NOMINAL DOOR HEIGHT	6'8"	7'0"	7'2"	8'0"	10'0"
ACTUAL HINGE LENGTH	79"	83"	85"	95"	120"
FRAME	12-24 x 3/4" PHILLIPS FLAT HEAD, UNDERCUT, SELF DRILLING, THREAD FORMING TEK MACHINE SCREW				
	18	18	18	20	23
DOOR	12-24 x 3/4" PHILLIPS FLAT HEAD, UNDERCUT, SELF DRILLING, THREAD FORMING TEK MACHINE SCREW				
	18	18	18	20	23

A110HD-EA OPTION, EASY ACCESS CONCEALED ELECTRIFICATION-1-04.DWG



www.abhmfg.com  
E-mail: abhinfo@abhmfg.com  
Architectural Builders Hardware Mfg., Inc.  
1222 Ardmore Ave., Itasca, IL 60143  
630.875.9900; FAX 800.9FAXABH (932.9224)

**A110HD/LL - "EA" OPTION EASY ACCESS  
CONCEALED ELECTRIFICATION**

© 2022 ABH Mfg., Inc.  
printed in USA

**A110HD/LL - "EA" OPTION, EASY ACCESS CONCEALED ELECTRIFICATION,  
ALUMINUM GEARED HINGE**

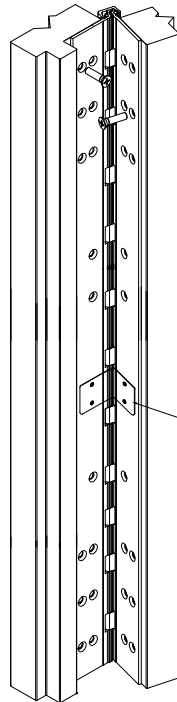
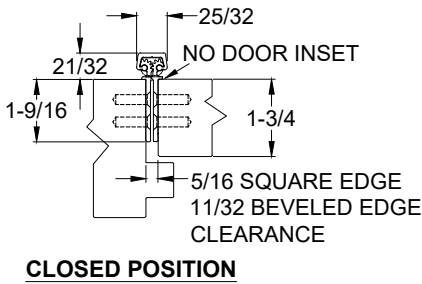
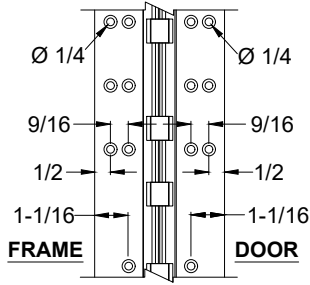

**ISOMETRIC VIEW  
~90° OPENING**

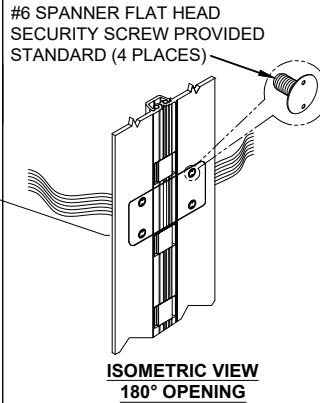

**ISOMETRIC VIEW  
180° OPENING**

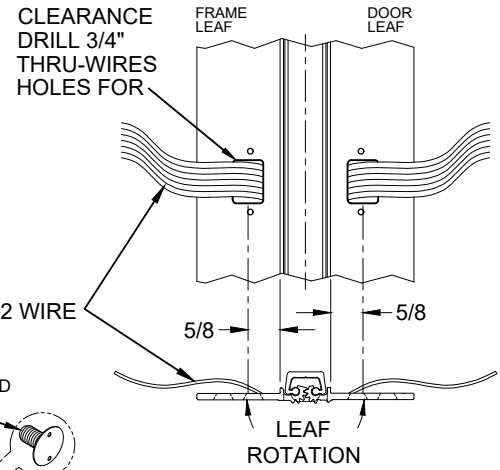

**WIRE TRANSFER VIEW**

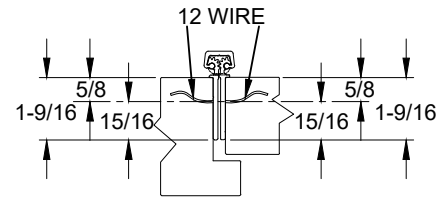

**WIRE TRANSFER VIEW**

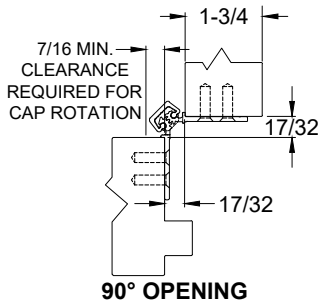

**90° OPENING**

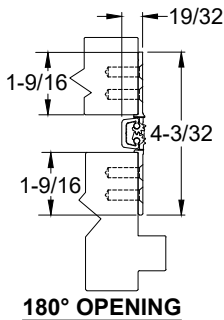

**180° OPENING**

**NOTES:**

1. MOLEX <sup>®</sup> CONNECTOR OPTION AVAILABLE - SUFFIX "EZ".

\* SPECIFY ELECTRIFIED HARDWARE MANUFACTURER FOR CONNECTOR COMPABILITY

**EZ CONNECT OPTION**

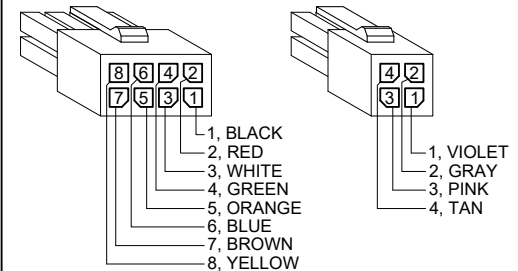

**SPECIFICATION:**

**DESCRIPTION:** SINGLE CONDUCTOR #22 AWG MINIATURE HOOK-UP WIRE FOR APPLICATIONS REQUIRING EXTREME FLEXIBILITY.

**CONDUCTOR:** #22 AWG 168/44 (0.002") SOFT BARE COPPER LHL.

**INSULATION:** PROPRIETARY FORMULATION PVC 0.010" NOM. WALL MEETS VW-1 FLAME REQUIREMENT.

**DIAMETER:** 0.053" ± 0.003".

**RESISTANCE:** 16.7 OHMS MAX. @ 20°C, PER 1000 FT.

**VOLTAGE RATING:** 600 VOLTS RMS, DEPENDING ON SPECIFICATION.

**AVAILABLE AS RoHS COMPLIANT.**



www.abhmfg.com  
E-mail: abhinfo@abhmfg.com  
Architectural Builders Hardware Mfg., Inc.  
1222 Ardmore Ave., Itasca, IL 60143  
630.875.9900; FAX 800.9FAXABH (932.9224)

A110HD-EA OPTION, EASY ACCESS CONCEALED ELECTRIFICATION-2-04.DWG

**A110HD/LL - "EA" OPTION EASY ACCESS  
CONCEALED ELECTRIFICATION**

© 2022 ABH Mfg., Inc.  
printed in USA

PAGE 2 OF 2  
REVISED 08-10-22

# A110HD/LL - "EA" & "R" ELECTRICAL MODIFICATION WITH REMOVABLE OPTION

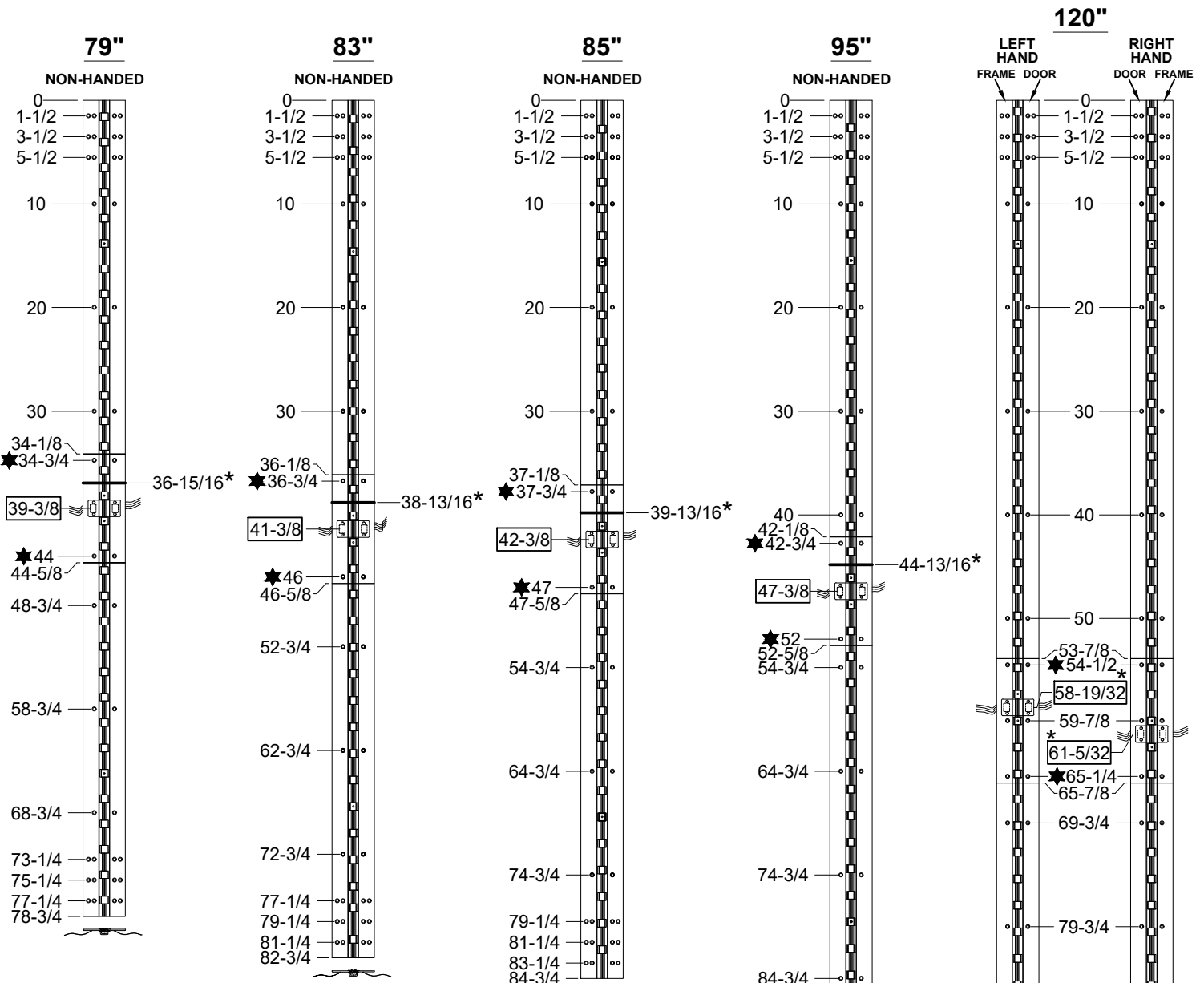

## 12 WIRE STANDARD

### NOTES:

1. HINGES CUT TO CUSTOM LENGTH ARE CUT FROM BOTTOM OF HINGE. CUSTOM CUT HINGE REQUIRES HANDING.

R = REMOVABLE, (3) INDIVIDUAL HINGES, THRU WIRE CAN BE REMOVED TO ACCESS WIRES.

★ = MANUFACTURING TO ADD (4) COUNTERSINK THRU HOLES FOR #12 FLAT HEAD SCREW.



□ = STANDARD LOCATION

\* = LL (LEAD LINED) OPTION (HANDED) LOCATION

### STANDARD HINGE SIZES & SCREW DETAIL

NOMINAL DOOR HEIGHT		6'8"	7'0"	7'2"	8'0"	10'0"
ACTUAL HINGE LENGTH		79"	83"	85"	95"	120"
FRAME	12-24 x 3/4" PHILLIPS FLAT HEAD, UNDERCUT, SELF DRILLING, THREAD FORMING TEK MACHINE SCREW	20	20	20	22	25
DOOR	12-24 x 3/4" PHILLIPS FLAT HEAD, UNDERCUT, SELF DRILLING, THREAD FORMING TEK MACHINE SCREW	20	20	20	22	25

A110HD-EA & R, ELECTRICAL MODIFICATION WITH REMOVABLE OPTION-1-03.DWG



www.abhmfg.com  
 E-mail: abhinfo@abhmfg.com  
 Architectural Builders Hardware Mfg., Inc.  
 1222 Ardmore Ave., Itasca, IL 60143  
 630.875.9900; FAX 800.9FAXABH (932.9224)

© 2022 ABH Mfg., Inc.  
 printed in USA

**A110HD/LL - "EA" & "R"**  
 ELECTRICAL MODIFICATION  
 WITH REMOVABLE OPTION

PAGE 1 OF 2  
 REVISED 08-22-22

# A110HD/LL - "EA" & "R" ELECTRICAL MODIFICATION WITH REMOVABLE OPTION

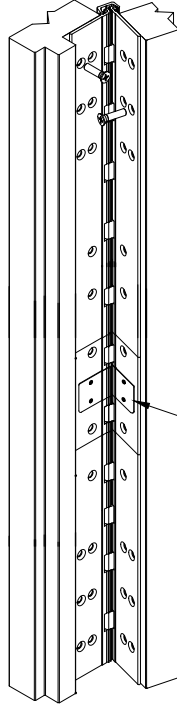
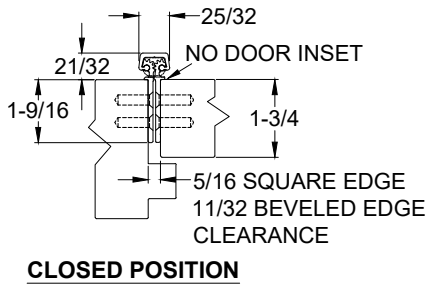
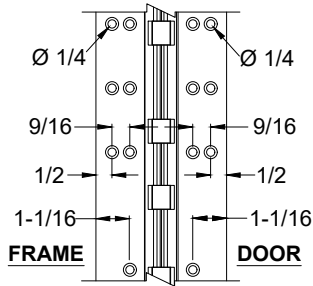

**ISOMETRIC VIEW**  
~90° OPENING

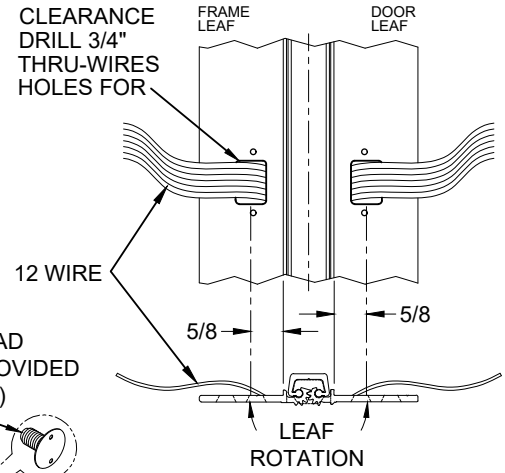

**WIRE TRANSFER VIEW**

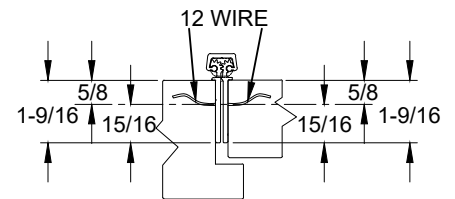

**WIRE TRANSFER VIEW**

**ISOMETRIC VIEW**  
180° OPENING

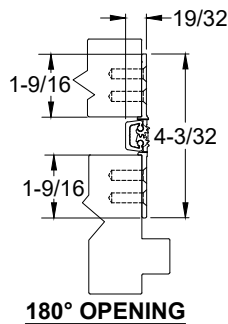
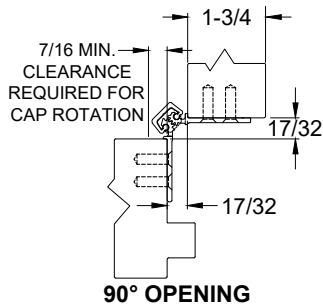

**NOTES:**

1. MOLEX  CONNECTOR OPTION  
AVAILABLE - SUFFIX "EZ".

\* SPECIFY ELECTRIFIED HARDWARE  
MANUFACTURER FOR CONNECTOR  
COMPABILITY

**EZ CONNECT OPTION**

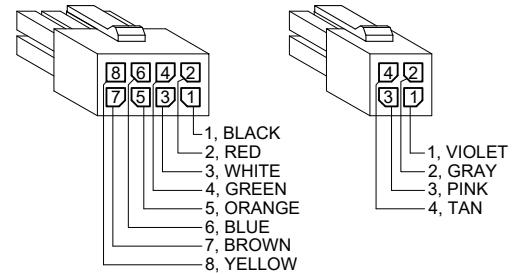

**SPECIFICATION:**

**DESCRIPTION:** SINGLE CONDUCTOR #22 AWG MINIATURE HOOK-UP  
WIRE FOR APPLICATIONS REQUIRING EXTREME FLEXIBILITY.

**CONDUCTOR:** #22 AWG 168/44 (0.002") SOFT BARE COPPER LHL.

**INSULATION:** PROPRIETARY FORMULATION PVC 0.010" NOM. WALL MEETS  
VW-1 FLAME REQUIREMENT.

**DIAMETER:** 0.053" ± 0.003".

**RESISTANCE:** 16.7 OHMS MAX. @ 20°C, PER 1000 FT.

**VOLTAGE RATING:** 600 VOLTS RMS, DEPENDING ON SPECIFICATION.

AVAILABLE AS RoHS COMPLIANT.



**A110HD - "EM" OPTION, CONCEALED ELECTRIFICATION, FULL CONCEALED,  
ALUMINUM GEARED HINGE**

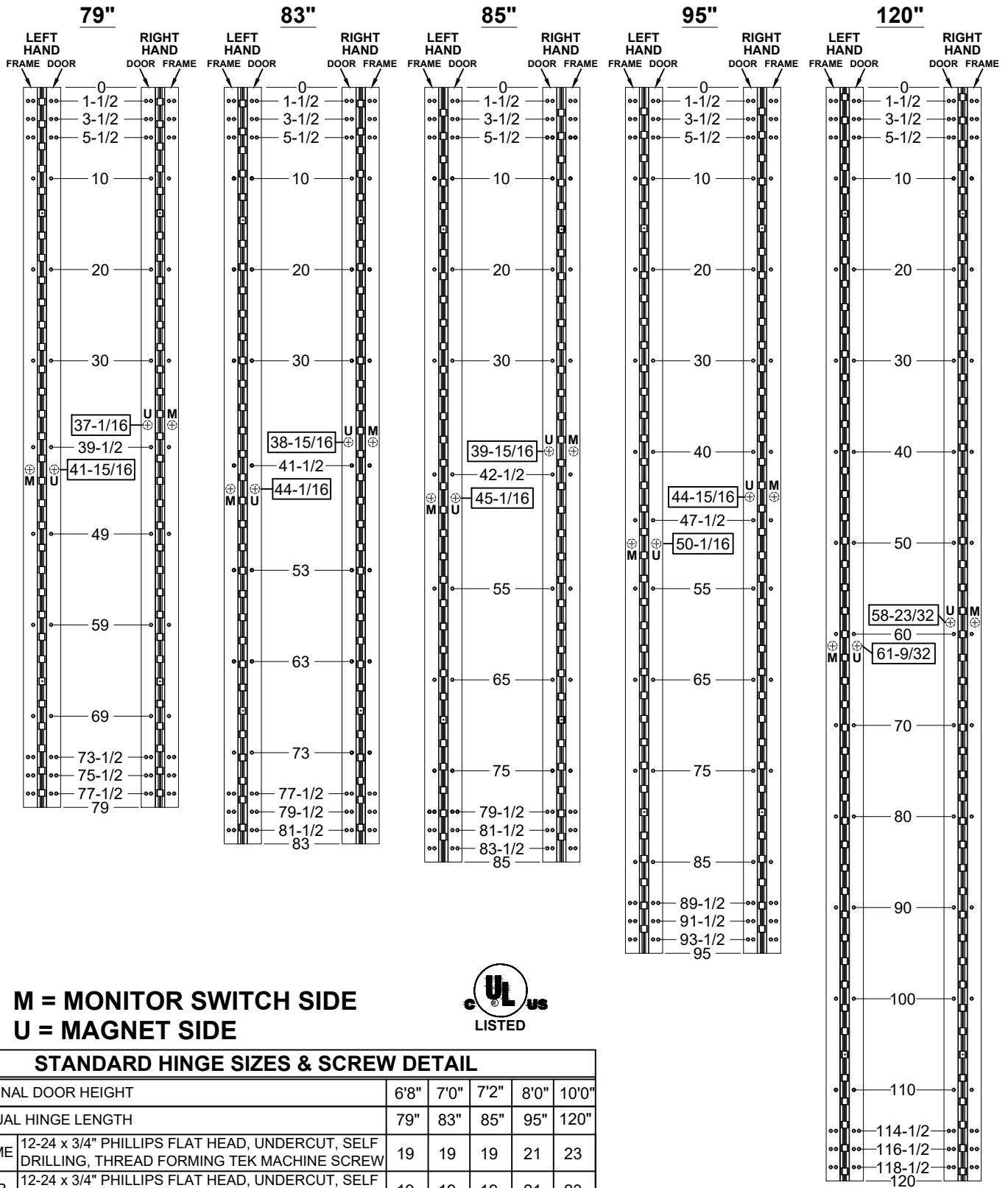

**M = MONITOR SWITCH SIDE**  
**U = MAGNET SIDE**



**STANDARD HINGE SIZES & SCREW DETAIL**

NOMINAL DOOR HEIGHT		6'8"	7'0"	7'2"	8'0"	10'0"
ACTUAL HINGE LENGTH		79"	83"	85"	95"	120"
FRAME	12-24 x 3/4" PHILLIPS FLAT HEAD, UNDERCUT, SELF DRILLING, THREAD FORMING TEK MACHINE SCREW	19	19	19	21	23
DOOR	12-24 x 3/4" PHILLIPS FLAT HEAD, UNDERCUT, SELF DRILLING, THREAD FORMING TEK MACHINE SCREW	19	19	19	21	23

A110HD-EM OPTION, CONCEALED ELECTRIFICATION-1-02.DWG



www.abhmf.com  
E-mail: abhinfo@abhmf.com  
Architectural Builders Hardware Mfg., Inc.  
1222 Ardmore Ave., Itasca, IL 60143  
630.875.9900; FAX 800.9FAXABH (932.9224)

© 2020 ABH Mfg., Inc.  
printed in USA

**A110HD - "EM" OPTION**  
**CONCEALED ELECTRIFICATION**

PAGE 1 OF 2  
REVISED 9-23-20

**A110HD - "EM" OPTION, CONCEALED ELECTRIFICATION, FULL CONCEALED,  
ALUMINUM GEARED HINGE**

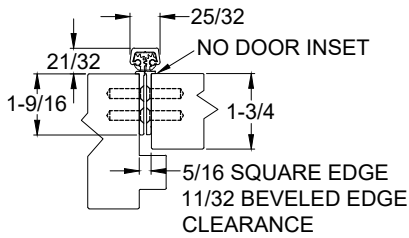

**CLOSED POSITION**

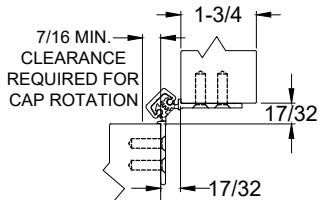

**90° OPENING**

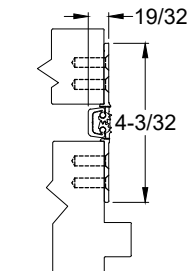

**180° OPENING**

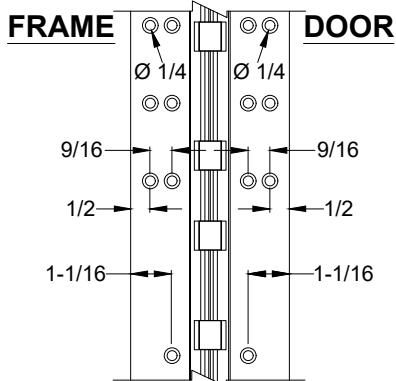
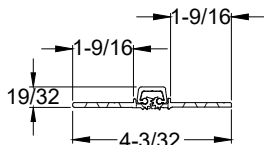

**NOTES:**

1. HINGES CUT TO CUSTOM LENGTH ARE CUT FROM BOTTOM OF HINGE.
2. SPECIFY HANDING WHEN ORDERING.
3. IF "M" OPTION (MOVEABLE PANEL) OR "R" OPTION (REMOVABLE PANEL) IS CHOSEN, TEMPLATE REMAINS THE SAME.

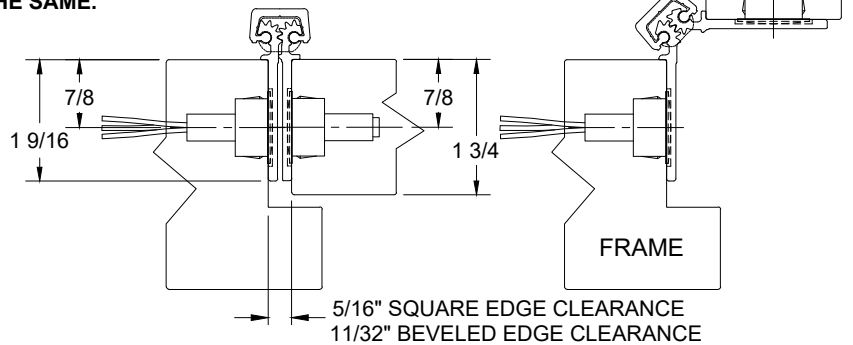

**MAGNETIC MONITOR SWITCH VIEW,  
LEFT HAND SHOWN**

NOTE: 7/8" DIA. MIN. CLEARANCE HOLE REQUIRED IN DOOR & FRAME FOR MONITORING SWITCH AND MAGNET

ELECTRICAL CONFIG.: SPDT  
 MAX. INITIAL CONTACT RESISTANCE : 0.140 OHM  
 MAX. CONTACT RATING: 5 WATT  
 MAX. SWITCHING VOLTAGE: 175 VDC  
 MAX. SWITCHING CURRENT: 0.25 AMP

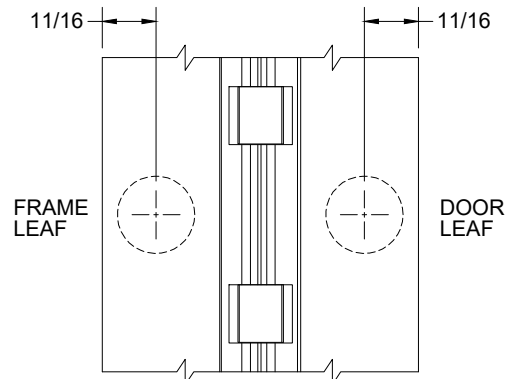
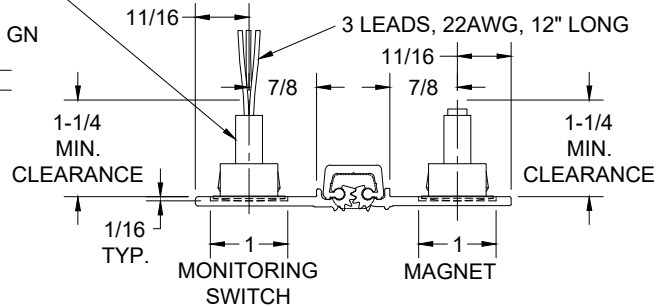
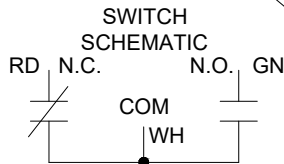

**MAGNETIC MONITOR SWITCH VIEW**

A110HD-EM OPTION, CONCEALED ELECTRIFICATION-2-02.DWG

**A110HD - "ES" OPTION, CONCEALED ELECTRIFICATION, FULL CONCEALED,  
ALUMINUM GEARED HINGE**

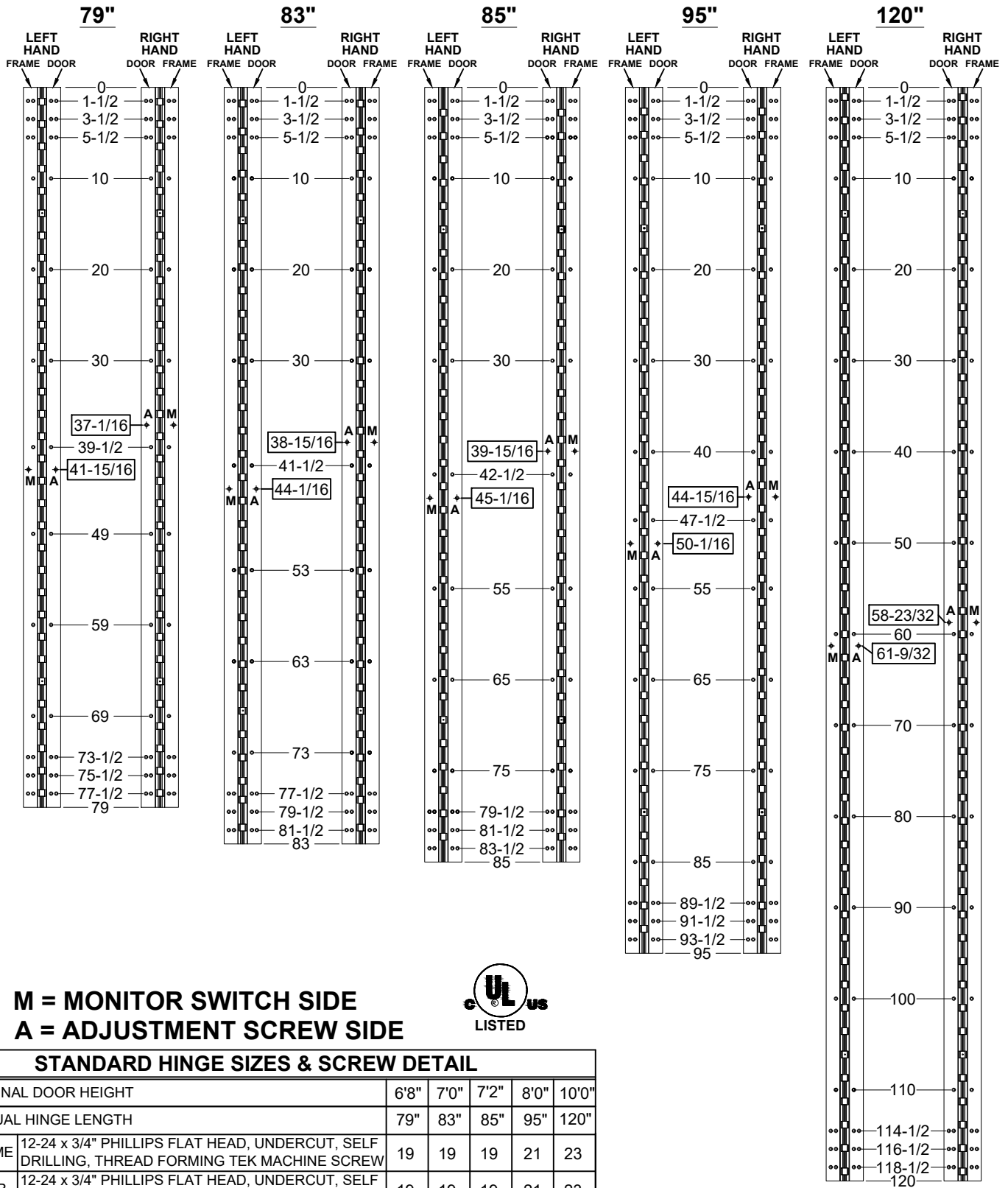

**M = MONITOR SWITCH SIDE**  
**A = ADJUSTMENT SCREW SIDE**



**STANDARD HINGE SIZES & SCREW DETAIL**

NOMINAL DOOR HEIGHT	6'8"	7'0"	7'2"	8'0"	10'0"
ACTUAL HINGE LENGTH	79"	83"	85"	95"	120"
FRAME	12-24 x 3/4" PHILLIPS FLAT HEAD, UNDERCUT, SELF DRILLING, THREAD FORMING TEK MACHINE SCREW				
	19	19	19	21	23
DOOR	12-24 x 3/4" PHILLIPS FLAT HEAD, UNDERCUT, SELF DRILLING, THREAD FORMING TEK MACHINE SCREW				
	19	19	19	21	23

A110HD-ES OPTION, CONCEALED ELECTRIFICATION-1-02.DWG



www.abhmfg.com  
E-mail: abhinfo@abhmfg.com  
Architectural Builders Hardware Mfg., Inc.  
1222 Ardmore Ave., Itasca, IL 60143  
630.875.9900; FAX 800.9FAXABH (932.9224)

© 2020 ABH Mfg., Inc.  
printed in USA

**A110HD - "ES" OPTION**  
**CONCEALED ELECTRIFICATION**

PAGE 1 OF 2  
REVISED 9-23-20

**A110HD - "ES" OPTION, CONCEALED ELECTRIFICATION, FULL CONCEALED,  
ALUMINUM GEARED HINGE**

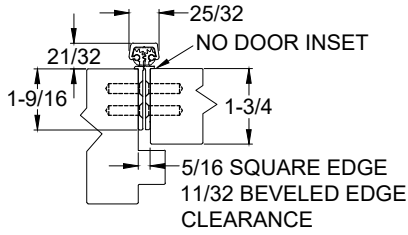

**CLOSED POSITION**

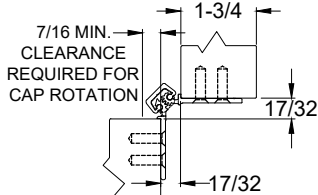

**90° OPENING**

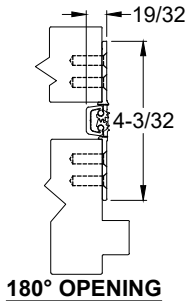

**180° OPENING**

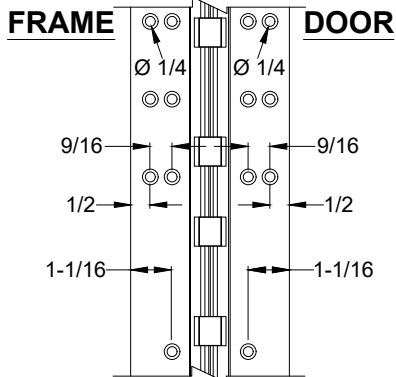
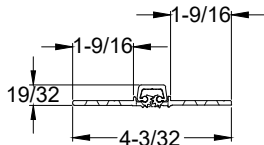

**NOTES:**

1. HINGES CUT TO CUSTOM LENGTH ARE CUT FROM BOTTOM OF HINGE.
2. SPECIFY HANDING WHEN ORDERING.
3. IF "M" OPTION (MOVEABLE PANEL) OR "R" OPTION (REMOVABLE PANEL) IS CHOSEN, TEMPLATE REMAINS THE SAME.

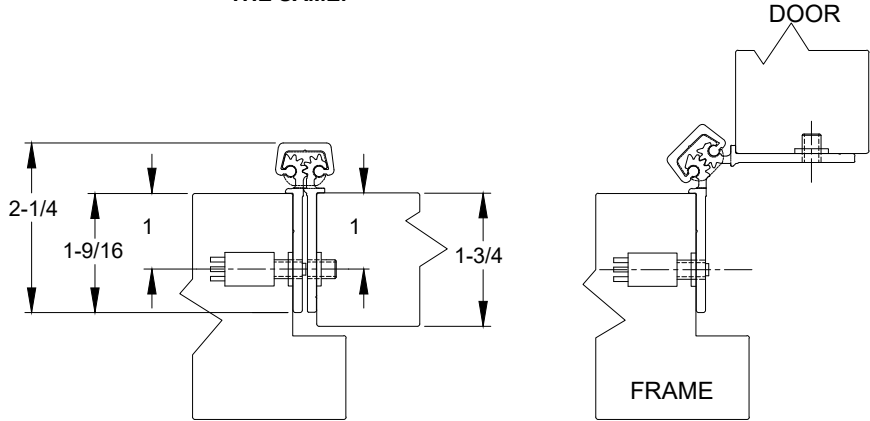

**EXPOSED MONITOR SWITCH VIEW, LEFT HAND SHOWN**

**SWITCH SCHEMATIC**

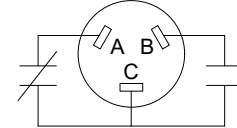

A & C = NORMALLY CLOSED  
B & C = NORMALLY OPEN

NOTE: 5/8" DIA. HOLE REQUIRED IN JAMB FOR MONITORING SWITCH AND A 7/16" DIA. HOLE FOR CLEARANCE OF ADJUSTMENT SCREW

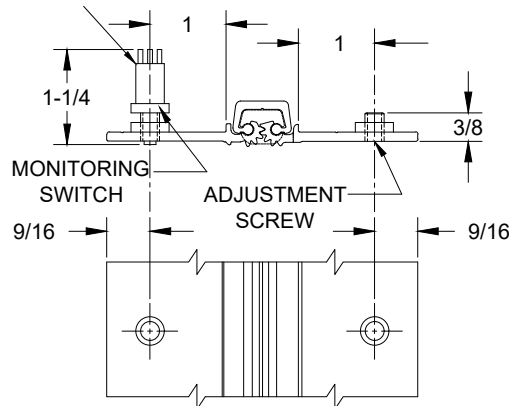

**EXPOSED MONITOR SWITCH VIEW**

A110HD-ES OPTION, CONCEALED ELECTRIFICATION-2-02.DWG

# UL FIRE RATED STUDS FOR INSTALLATION

## FULL CONCEALED ALUMINUM GEARED HINGES

MODELS A110HD/LL, A111HD/LL, A140HD/LL, A150HD/LL, A160HD/LL, A240HD/LL, A260HD/LL  
A270HD/LL, A280HD/LL & A410HD/LL

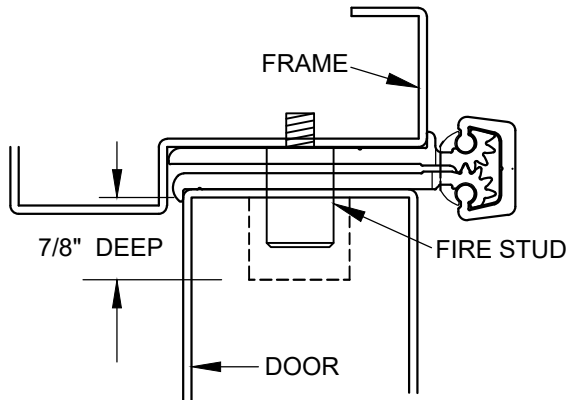

**DOOR SHOWN CLOSED WITH FIRE STUD IN PLACE  
USING MODEL A240HD HINGE**

**NOTES:**

1. INSTALL HINGE PER INSTALLATION INSTRUCTIONS FOR EACH MODEL.
2. FOR THE FRAME SIDE - DRILL AND TAP (4) 12-24 HOLES FOR FIRE STUDS.
3. FOR THE DOOR SIDE - DRILL (4) 3/4" DIA. HOLES IN THE DOOR TO CORRESPOND TO THE STUD HOLES IN THE FRAME SIDE.
4. INSERT STUDS IN THE FOUR (4) TAPPED FRAME HOLES, TIGHTEN SECURELY.
5. SLOWLY CLOSE DOOR MAKING SURE THAT THE STUDS ARE PROPERLY ALIGNED.
6. MINOR INTERFERENCE CAN BE TAKEN CARE OF WITH A ROUND METAL FILE.

DIMENSION					
"A" HINGE LENGTH	79"	83"	85"	95"	120"
"B"	12"	12"	12"	12"	12"
"C"	25-3/8"	27-3/8"	28-3/8"	32-3/8"	42-1/2"
"D"	53-5/8"	55-5/8"	56-5/8"	62-5/8"	77-1/2"
"E"	67"	71"	73"	83"	108"

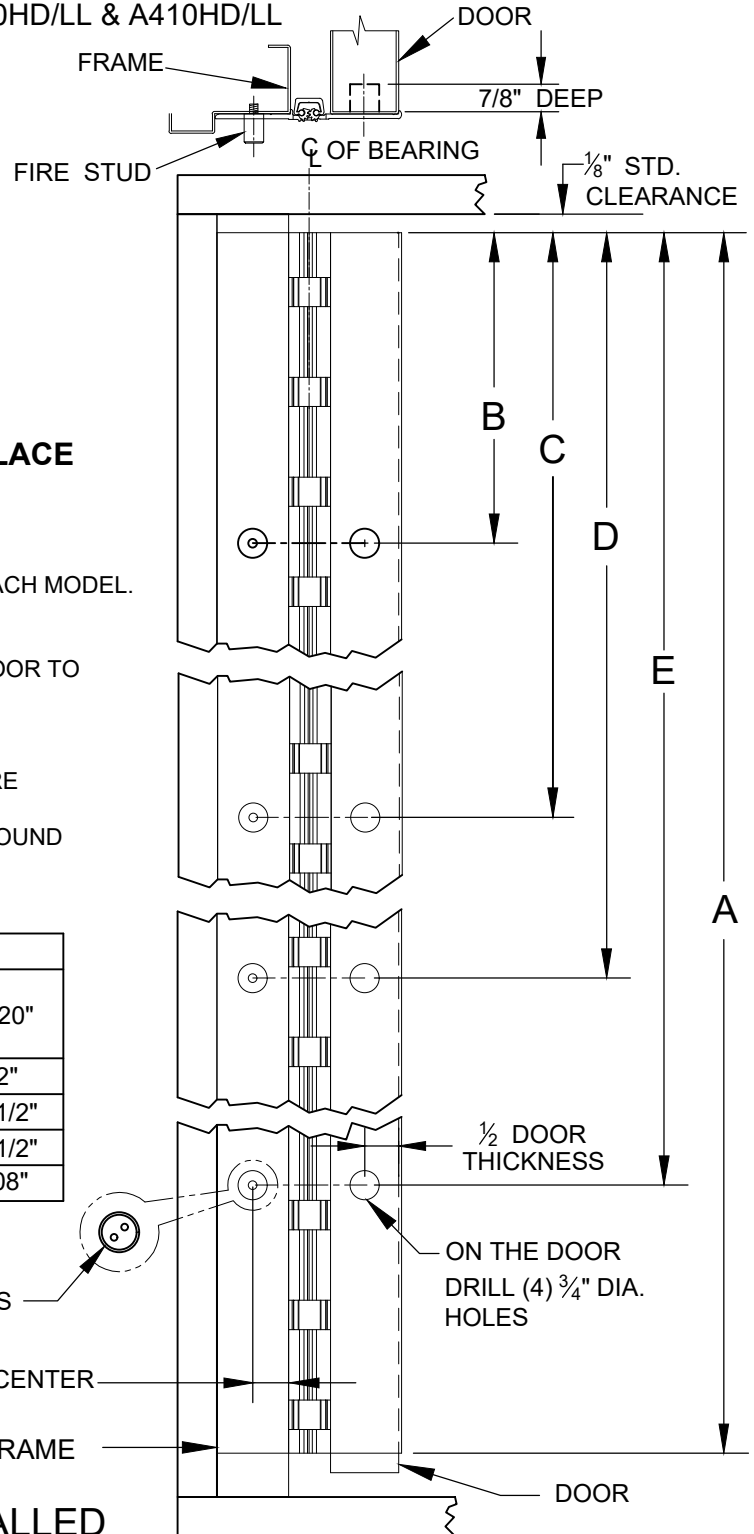

**DOOR SHOWN OPEN 180°**

ON THE FRAME, DRILL AND TAP (4) 12-24 HOLES

1/2 THE DOOR THICKNESS + 1/32" FROM CENTER OF HOLE TO EDGE OF FRAME

1/2 DOOR THICKNESS

ON THE DOOR DRILL (4) 3/4" DIA. HOLES

**ALL FOUR (4) STUDS MUST BE INSTALLED  
TO COMPLY WITH U.L. RATING**

FIRE STUD - FULL CONCEALED-03.DWG



www.abhmf.com  
E-mail: abhinfo@abhmf.com  
Architectural Builders Hardware Mfg., Inc.  
1222 Ardmore Ave., Itasca, IL 60143  
630.875.9900; FAX 800.9FAXABH (932.9224)

© 2021 ABH Mfg., Inc.  
printed in USA

**FIRE STUD -  
FULL CONCEALED**

PAGE 1 OF 1  
REVISED 11-22-21

## Door Clearance Chart Squared Edge

Single Door - Squared Edged							
Hinge Model		Hinge Thickness	+	Lock Side Clearance	+	*Frame Irregularity (OPTIONAL)	= Square Edged Door Undersized (Single)
Full Concealed	A110, A110WT, A111 A111WT, A120, A140, A150, A160, A240, A260, A270, A410	5/16"	+	1/8"	+	1/32"	= 15/32"
	A130, A135	13/16"	+	1/8"	+	1/32"	= 3 1/32"
Half Surface	A211, A213, A450, A460, A520, A530, A540, A550	3/16"	+	1/8"	+	1/32"	= 1 1/32"
Full Surface	A210, A570, A571, A575	1/16"	+	1/8"	+	1/32"	= 7/32"

Single Door

Pair of Doors

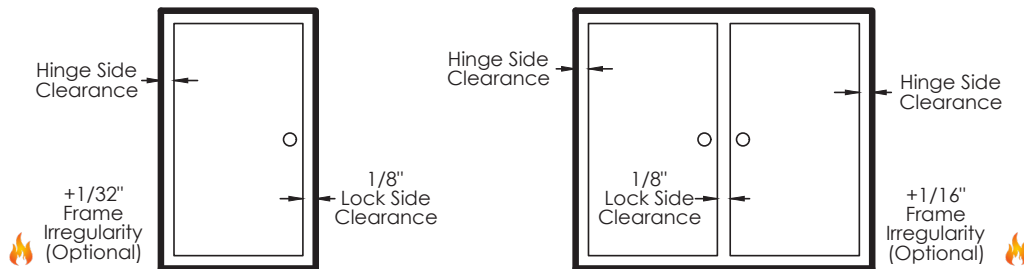

Pair of Doors - Squared Edged							
Hinge Model		Hinge Thickness (Pair)	+	Lock Side Clearance	+	*Frame Irregularity (OPTIONAL)	= Square Edged Door Undersized (Pair)
Full Concealed	A110, A110WT, A111 A111WT, A120, A140, A150, A160, A240, A260, A270, A410	5/8"	+	1/8"	+	1/16"	= 13/16"
	A130, A135	1-5/8"	+	1/8"	+	1/16"	= 1-13/16"
Half Surface	A211, A213, A450, A460, A520, A530, A540, A550	1/4"	+	1/8"	+	1/16"	= 7/16"
Full Surface	A210, A570, A571, A575	1/8"	+	1/8"	+	1/16"	= 5/16"

\* 1/16" Frame Irregularity Allowance, Optional and included in all Total Door Undersize for single and pairs of doors

Frame irregularity not permitted by NFPA80

## Door Clearance Chart Beveled Edge

Single Door - Beveled Edged										
Hinge Model		Hinge Thickness	+	Lock Side Clearance	+	* Frame Irregularity (OPTIONAL)	+	Beveled Door Clearance	=	Beveled Edged Door Undersized (Single)
Full Concealed	A110, A110WT, A111 A111WT, A120, A140, A150, A160, A240, A260, A270, A410	5/16"	+	1/8"	+	1/32"	+	1/32"	=	1/2"
	A130, A135	13/16"	+	1/8"	+	1/32"	+	1/32"	=	1"
Half Surface	A211, A213, A450, A460, A520, A530, A540, A550	3/16"	+	1/8"	+	1/32"	+	1/32"	=	3/8"
Full Surface	A210, A570, A571, A575	1/16"	+	1/8"	+	1/32"	+	N/A	=	7/32"

Single Door

Pair of Doors

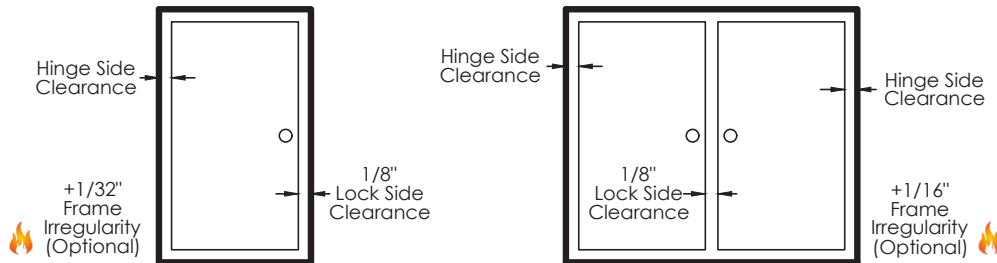

Pair of Doors - Beveled Edged										
Hinge Model		Hinge Thickness (Pair)	+	Lock Side Clearance	+	* Frame Irregularity (OPTIONAL)	+	Beveled Door Clearance	=	Beveled Edged Door Undersized (Pair)
Full Concealed	A110, A110WT, A111 A111WT, A120, A140, A150, A160, A240, A260, A270, A410	5/8"	+	1/8"	+	1/16"	+	1/16"	=	7/8"
	A130, A135	1-5/8"	+	1/8"	+	1/16"	+	1/16"	=	1-7/8"
Half Surface	A211, A213, A450, A460, A520, A530, A540, A550	1/4"	+	1/8"	+	1/16"	+	N/A	=	7/16"
Full Surface	A210, A570, A571, A575	1/8"	+	1/8"	+	1/16"	+	N/A	=	5/16"

\* 1/16" Frame Irregularity Allowance, Optional and included in all Total Door Undersize for single and pairs of doors

Frame irregularity not permitted by NFPA80

# ABH EZ CONNECT WIRE COLOR & POSITION STANDARD FOR MOLEX™ MICRO-FIT 3.0 CONNECTOR

(TERMINAL INSERTION END SHOWN)

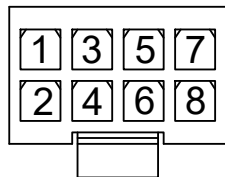

- 1: BLACK
- 2: RED
- 3: WHITE
- 4: GREEN
- 5: ORANGE
- 6: BLUE
- 7: BROWN
- 8: YELLOW

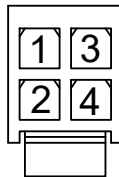

- 1: VIOLET
- 2: GREY
- 3: PINK
- 4: TAN

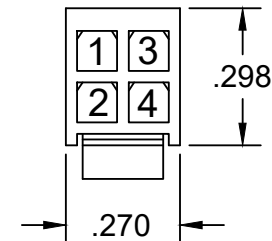
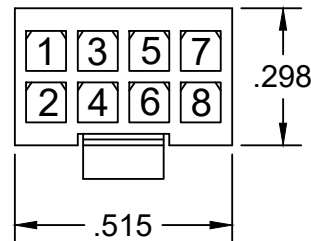

**NOTE:**  
ABH CAN MATCH ANY MANUFACTURERS  
WIRE COLOR POSITION

**AVAILABLE ON**

- STAINLESS STEEL CONTINUOUS HINGE
- ALUMINUM CONTINUOUS HINGES
- POWER TRANSFER UNITS
- PIVOTS
- ABH MORTISE LOCKS

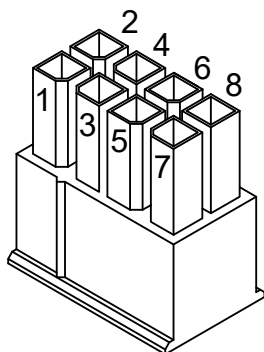

8-PIN HOUSING  
WIRE POSITION

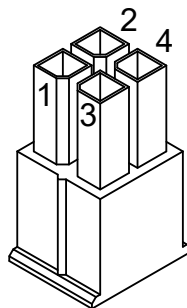

4-PIN HOUSING  
WIRE POSITION

CONNECTORS COMPATIBLE WITH CONNECTORS  
ON ASSA ABLOY PRODUCTS\*

\* BRAND NAMES ARE TRADEMARKS OR REGISTERED TRADEMARKS OF THEIR RESPECTIVE COMPANIES

PT1000EZ WIRE COLOR-ASSA ABLOY-06.DWG



www.abhmfg.com  
E-mail: abhinfo@abhmfg.com  
Architectural Builders Hardware Mfg., Inc.  
1222 Ardmore Ave., Itasca, IL 60143  
630.875.9900; FAX 800.9FAXABH (932.9224)

© 2022 ABH Mfg., Inc.  
printed in USA

EZ CONNECT WIRE COLOR & POSITION  
STANDARD FOR MOLEX™ CONNECTOR

PAGE 1 OF 1  
REVISED 03-15-22



# POWDER COAT MASKING

**MUST HANG PART  
AS SHOWN TO PREVENT  
PART FROM BENDING  
BY THE CUTOUT**

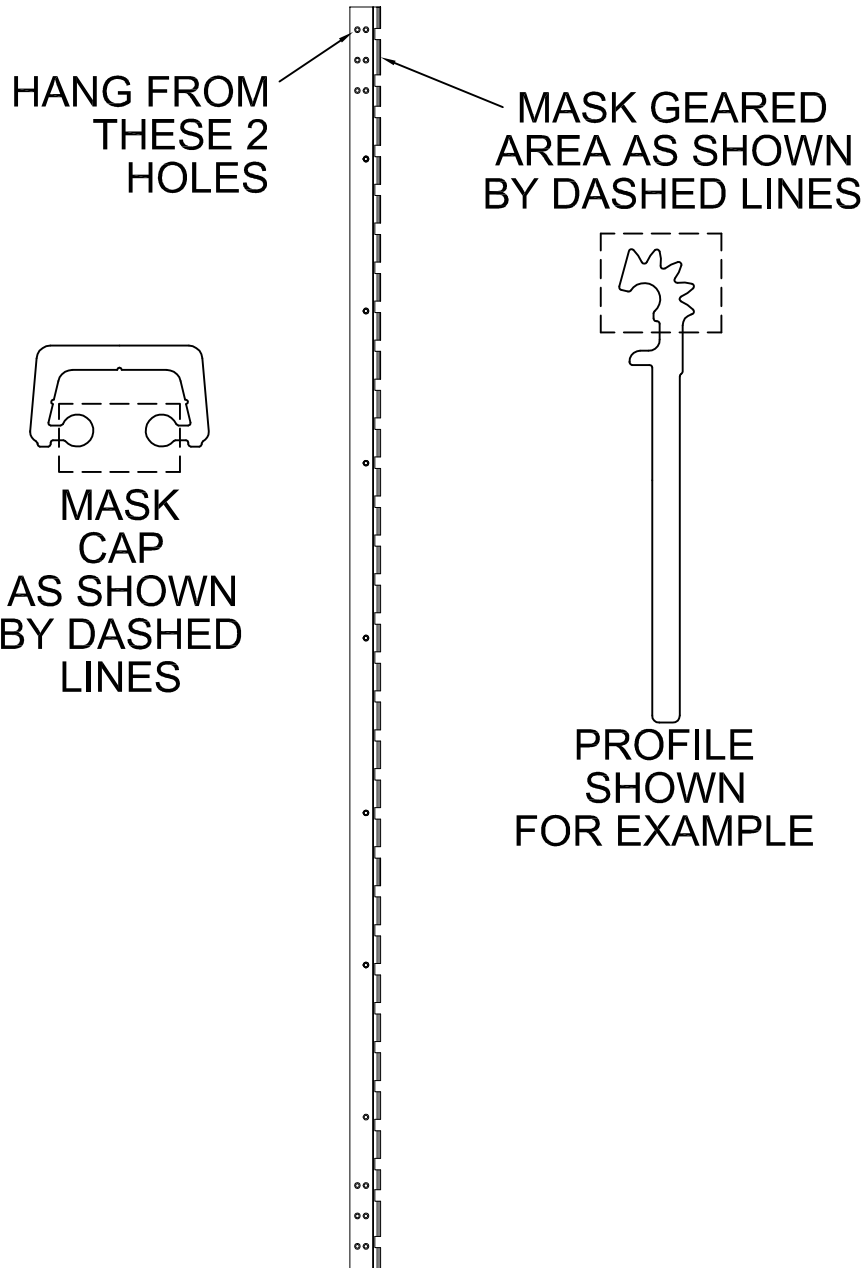

® [www.abhmfg.com](http://www.abhmfg.com)  
E-mail: [abhinfo@abhmfg.com](mailto:abhinfo@abhmfg.com)  
Architectural Builders Hardware Mfg., Inc.  
1222 Ardmore Ave., Itasca, IL 60143  
630.875.9900; FAX 800.9FAXABH (932.9224)

POWDER COAT MASKING-00.DWG

POWDER COAT MASKING

© 2008 ABH Mfg., Inc.  
printed in USA

PAGE 1 OF 1  
ISSUED 12-15-08

# INSTALLATION INSTRUCTIONS FOR FULL CONCEALED HINGES

A110HD/LL, A111HD/LL, A130HD, A135HD, A140HD/LL, A150HD/LL, A160HD/LL  
A240HD/LL, A260HD/LL, A270HD/LL, A280HD/LL & A410HD/LL

- A. All uncut standard length hinges are non-handed and can be used for right or left hand doors.
- B. Standard length hinges are supplied slightly shorter than nominal door height to accommodate threshold and carpeting clearances.

## CUTTING THE HINGE TO FIT

- Keep hinge in the closed position
- Determine **HANDING** if required. Not all hinges will become handed after cutting.
- Cut one end of the hinge only. Cut end will be installed at the bottom (Six-hole pattern remains at the top)
- Use a Metal Cutting Saw cut through the gear cap first.

**Note:** If cut length interferes with a set screw bearing remove it and switch it with a plain bearing above the cut location.

## FRAME PREP

With the hinge in the open position

1. Locate the top of the hinge 1/8" below the header

With the frame leaf flange tight against the frame

2. Mark or Center Punch hole locations

**Note:** If using wood screws drill a 5/32" pilot hole

**DO NOT ATTACH HINGE TO FRAME AT THIS TIME**

## ATTACH THE HINGE TO THE DOOR

4. Position Door Leaf on door. Door leaf alignment flange or door leaf lip must be seated against door edge.
5. Align the top end of the hinge to be absolutely flush with the top of the door.
6. Mark or Center Punch hole locations
7. Using the provided Self Drilling/Thread Forming Screws and the proper drive bit please proceed to attach the hinge to the door

**Note:** If using wood screws drill a 5/32" pilot hole.

## ATTACHING DOOR TO FRAME

8. Position door 90 degrees to frame
9. Shim door to the proper height to line up the screw holes in hinge frame leaf with the marks at the top of the frame.
10. Install two screws at the top of the hinge to hold in place
11. Remove shim and align the remaining holes. Install two additional screws in the middle and at the bottom.
12. Check door for proper swing and clearance before installing remaining screws, making necessary adjustments.
13. Install the remaining fasteners after any adjustments are made.

## REINFORCING AND RIVNUTS

- No reinforcing is necessary except on extremely high-frequency, extremely heavy or extra-wide doors.
- Rivnuts are recommended for use in the frame when the door exceeds 450lbs.

**Note:** RIVNUTS are **not** to be used with Fire Rated Hinges

## PAIRS OF DOORS WITH MULLIONS

- If the mullion is between the doors, install as single doors.
- If the mullion is behind the doors, install as a double doors.

## GROUT/SLUSHED-IN FRAMES

It is recommended that a mudguard be installed behind the frame for ease of installation. Do not use self-drill screws with grouted steel frames without a mudguard. If no mudguard has been used, drill holes through frame and remove grout for screw clearances. Do not oversize hole.

SCREW DETAIL	
FRAME	12-24 x 3/4" PHILLIPS FLAT HEAD, UNDERCUT, SELF DRILLING, THREAD FORMING TEK MACHINE SCREW
DOOR	12-24 x 3/4" PHILLIPS FLAT HEAD, UNDERCUT, SELF DRILLING, THREAD FORMING TEK MACHINE SCREW

**Note:** #12 x 1-1/2" FLAT HEAD UNDERCUT WOOD SCREWS AVAILABLE UPON REQUEST

The following actions will void any warranty, expressed or implied.

- Failure to Install the hinge according to ABH's specifications and requirements
- Use of Fasteners other than those supplied with the hinge.
- Unauthorized field modifications including removing any of the bearings, altering the original finish or painting the hinge.



**ABH Manufacturing Inc.**  
1222 Ardmore Avenue  
Itasca, IL 60143  
Ph: (630)875-9900 Fax: (800) 932-9224  
[www.abhmfg.com](http://www.abhmfg.com)

ANSI/BHMA A156.26-2017 Certified Continuous Hinges

Edge Mounted-Barrel Type-Stainless Steel-Grade 1

ABH Model Number(s): A500, A505, A515

Edge Mounted-Gear Type-Aluminum-Grade 1

ABH Model Number(s): A110(HD/LL), A110WT(HD/LL), A111(HD/LL),  
A111WT(HD/LL), A130HD, A140(HD/LL), A150(HD/LL), A160(HD/LL),  
A240(HD/LL), A260(HD/LL), A270(HD/LL), A410(HD/LL)

Full Surface Mounted-Barrel Type-Stainless Steel-Grade 1

ABH Model Number(s): A502, A512

Full Surface Mounted- Gear Type- Aluminum-Grade 1

ABH Model Number(s): A210HD, A570HD, A571HD

Half-Surface Mounted-Barrel Type-Stainless Steel-Grade 1

ABH Model Number(s): A503

Half-Surface Mounted- Gear Type- Aluminum-Grade 1

ABH Model Number(s): A211HD, A213HD, A450HD, A460HD, A530HD, A540HD,  
A550HD

Half Mortise Mounted-Barrel Type-Stainless Steel-Grade 1

ABH Model Number(s): A504, A506

Half Mortise Mounted- Gear Type- Aluminum-Grade 1

ABH Model Number(s): A520HD

Swing Clear Edge Mounted-Barrel Type-Stainless Steel-Grade 1

ABH Model Number(s): A510, A511, A526, A529

Swing Clear Edge Mounted- Gear Type- Aluminum-Grade 1

ABH Model Number(s): A410(HD/LL), A211HD

HD-denotes Heavy Duty Hinge

LL-denotes Heavy Duty hinge with extra screw holes to accommodate the lead in lead lined doors

# EA THRU-WIRE REPLACEMENT INSTRUCTIONS

## Removal of Old Wires

1. Turn off Power to avoid shock.
2. Remove (4) #6 Spanner Flat Head Screws from the covers on the face of each hinge leaf.

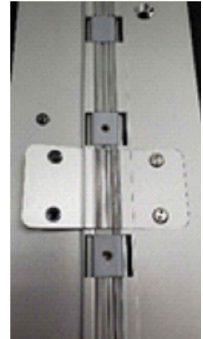

3. Remove (2) covers to expose the wires.



4. Pull wires through opening and disconnect from power source and electrified hardware.

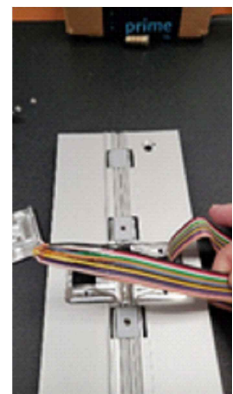

# EA THRU-WIRE REPLACEMENT INSTRUCTIONS

## Installation of New Wire Ribbon

**All wire connections must follow local codes and/or ABH Manufacturing's Minimum Requirements\*\* to ensure proper and lasting connections**

**\*\*ABH requires the use of wire nuts and electrical tape or Crimp Connectors when connecting wires to their source or supplied EZ Connectors**

1. Connect wire to the power source (FRAME SIDE) and pass wires back through hinge and frame opening.
2. Connect wires on DOOR side to electrified hardware and pass wires back through the hinge and door opening.

3. Excess Wire Ribbon should then be folded into the void of the cap.

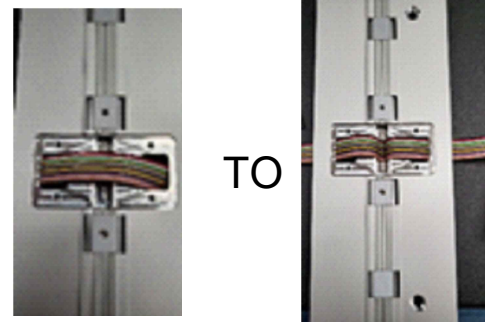

4. Once wires are properly connected, line up the Thru-Wire Face plate gears and fasten with (4) #6 Spanner Flat Head Screws, making sure the plates sit flush to the face of the hinge leaves.

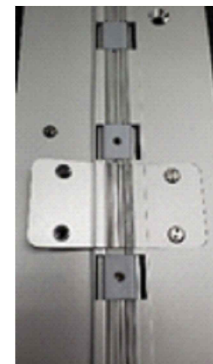

5. Turn Power back on