

Half Surface

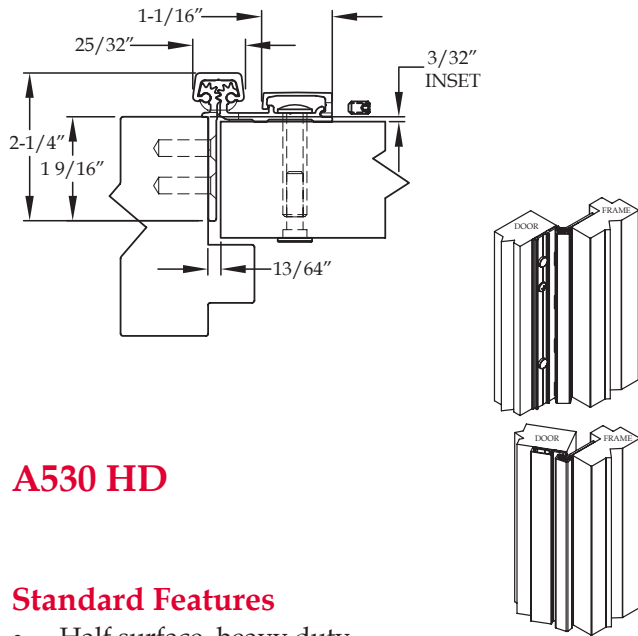

A530 HD

Standard Features

- Half surface, heavy duty
- $\frac{3}{32}$ " door inset
- 48" door width maximum
- 450 lbs. door weight maximum
- **Fasteners:** 12-24 x $\frac{7}{8}$ " undercut self-drilling, thread-forming tek machine screws for frame and $\frac{1}{4}$ -20 sex bolts and shoulder bolts for door
- **Standard lengths:** 79", 83", 85", 95" and 120"
- **Finishes:** Clear, dark bronze and black anodized
- **Fire Rating**
 - Approved for use on metal swinging type fire doors rated up to and including 90 minutes (Specify "FR" option for 3 hour rating)
 - Approved for use on wood swinging type fire doors rated up to and including 60 minutes (Specify "FR" option for 90 minute rating)

Options Available

- See pages F-7 to F-8 for option availability and details

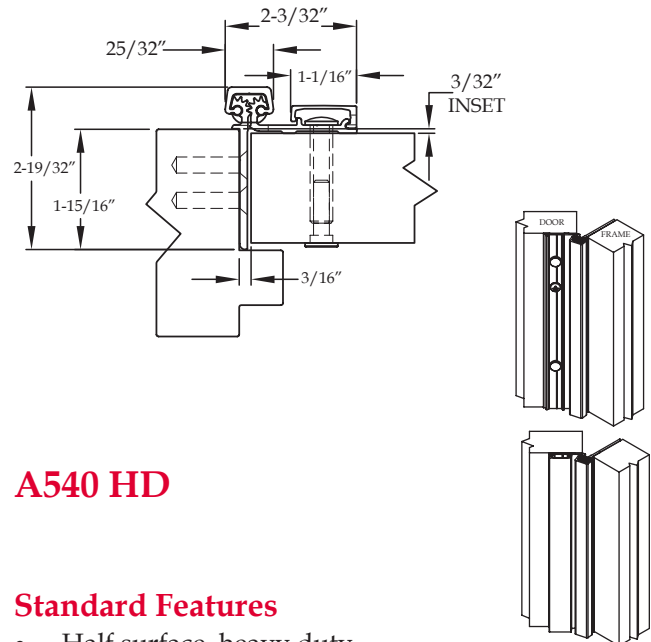

A540 HD

Standard Features

- Half surface, heavy duty
- $\frac{3}{32}$ " door inset
- 48" door width maximum
- 450 lbs. door weight maximum
- **Fasteners:** 12-24 x $\frac{7}{8}$ " undercut self-drilling, thread-forming tek machine screws for frame and $\frac{1}{4}$ -20 sex bolts and shoulder bolts for door
- **Standard lengths:** 79", 83", 85", 95" and 120"
- **Finishes:** Clear, dark bronze and black anodized
- **Fire Rating**
 - Approved for use on metal swinging type fire doors rated up to and including 90 minutes (Specify "FR" option for 3 hour rating)
 - Approved for use on wood swinging type fire doors rated up to and including 60 minutes (Specify "FR" option for 90 minute rating)

Options Available

- See pages F-7 to F-8 for option availability and details



A530 - ALUMINUM GEARED HINGE, 3/32" INSET, HALF SURFACE

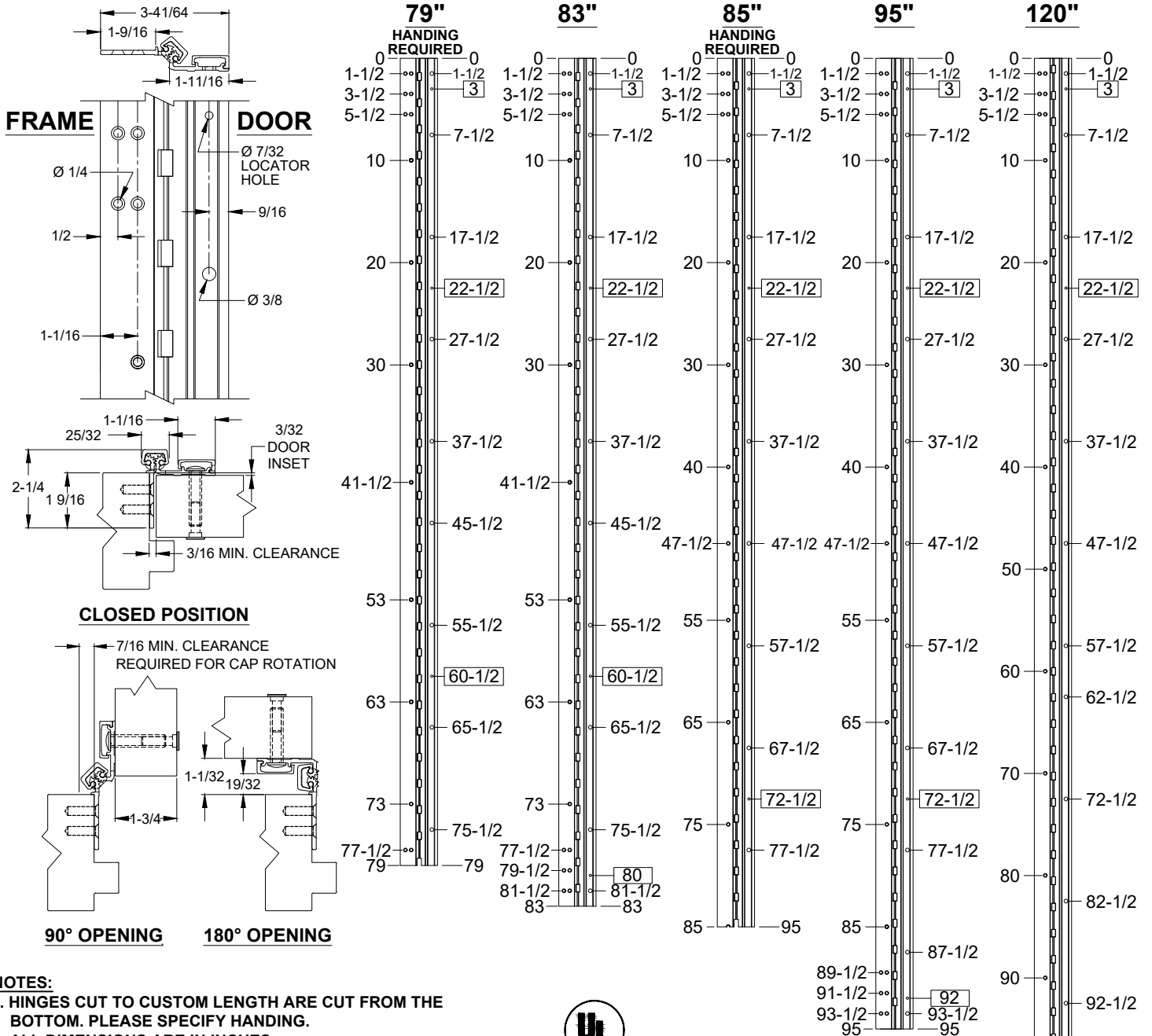

- NOTES:**
- HINGES CUT TO CUSTOM LENGTH ARE CUT FROM THE BOTTOM. PLEASE SPECIFY HANDING.
 - ALL DIMENSIONS ARE IN INCHES.
 - ALL DIMENSIONS ARE TO CENTERLINE OF HOLES.
 - XX" DENOTES LOCATOR HOLE.



STANDARD HINGE SIZES & SCREW DETAIL

NOMINAL DOOR HEIGHT		6'8"	7'0"	7'2"	8'0"	10'0"
ACTUAL HINGE LENGTH		79"	83"	85"	95"	120"
FRAME	12-24 x 3/4" PHILLIPS FLAT HEAD, UNDERCUT, SELF DRILLING, THREAD FORMING TEK MACHINE SCREW	15	19	14	21	23
DOOR	1/4-20 x 1-1/4" x 3/8 DIA. SEX BOLT & 1/4-20 x 1-1/4" PH. HEAD SHOULDER SCREW	9	10	9	11	14
	12-24 x 1" PH. PN. HD. SELF DRILLING TEK SCREW (LOCATOR HOLE)	3	4	3	4	4

A530-ALUMINUM GEARED HINGE-03.DWG



www.abhmfg.com
 E-mail: abhinfo@abhmfg.com
 Architectural Builders Hardware Mfg., Inc.
 1222 Ardmore Ave., Itasca, IL 60143
 630.875.9900; FAX 800.9FAXABH (932.9224)

© 2019 ABH Mfg., Inc.
 printed in USA

A530
ALUMINUM GEARED HINGE

PAGE 1 OF 1
 REVISED 9-10-20

UL FIRE RATED STUDS FOR INSTALLATION HALF SURFACE ALUMINUM GEARED HINGES

MODELS A211HD, A213HD, A450HD, A460HD, A530HD, A540HD & A550HD

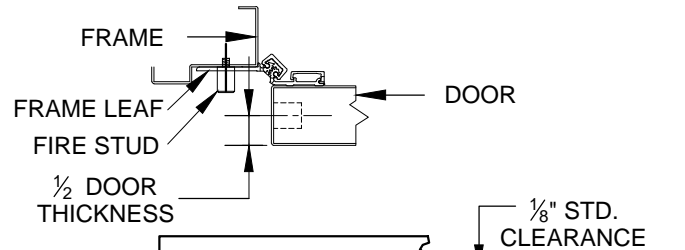
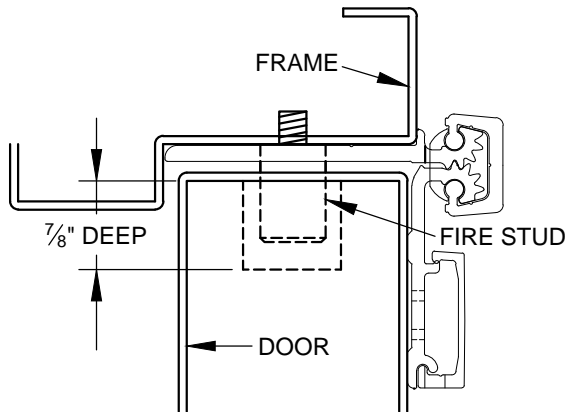

DOOR SHOWN CLOSED WITH FIRE STUD IN PLACE USING MODEL A540HD HINGE

NOTES:

1. INSTALL HINGE PER INSTALLATION INSTRUCTIONS FOR EACH MODEL.
2. FOR THE FRAME SIDE - DRILL AND TAP (4) 12-24 HOLES FOR FIRE STUDS.
3. FOR THE DOOR SIDE - DRILL (4) 3/4" DIA. HOLES IN THE DOOR TO CORRESPOND TO THE STUD HOLES IN THE FRAME SIDE.
4. INSERT STUDS IN THE FOUR (4) TAPPED FRAME HOLES, TIGHTEN SECURELY.
5. SLOWLY CLOSE DOOR MAKING SURE THAT THE STUDS ARE PROPERLY ALIGNED.
6. MINOR INTERFERENCE CAN BE TAKEN CARE OF WITH A ROUND METAL FILE.

DIMENSION					
"A" HINGE LENGTH	79"	83"	85"	95"	120"
"B"	12"	12"	12"	12"	12"
"C"	25-3/8"	27-3/8"	28-3/8"	32-3/8"	42-1/2"
"D"	53-5/8"	55-5/8"	56-5/8"	62-5/8"	77-1/2"
"E"	67"	71"	73"	83"	108"

ON THE FRAME, DRILL AND TAP (4)12-24 HOLES

1/2 DOOR THICKNESS + 1/32" FROM CENTER OF HOLE TO EDGE OF FRAME

ON THE DOOR DRILL (4) 3/4" DIA. x 7/8" DEEP HOLES

FRAME

HINGE

DOOR

**ALL FOUR (4) STUDS MUST BE INSTALLED
TO COMPLY WITH U.L. RATING**

DOOR SHOWN OPEN 90°



www.abhmfg.com
 E-mail: abhinfo@abhmfg.com
 Architectural Builders Hardware Mfg., Inc.
 1222 Ardmore Ave., Itasca, IL 60143
 630.875.9900; FAX 800.9FAXABH (932.9224)

©2016 ABH Mfg., Inc.
printed in USA

FIRE STUD - HALF SURFACE-01.DWG

**FIRE STUD -
HALF SURFACE**

PAGE 1 OF 1
REVISED 10-05-16

Door Clearance Chart Squared Edge

Single Door - Squared Edged							
Hinge Model		Hinge Thickness	+	Lock Side Clearance	+	*Frame Irregularity (OPTIONAL)	= Square Edged Door Undersized (Single)
Full Concealed	A110, A110WT, A111 A111WT, A120, A140, A150, A160, A240, A260, A270, A410	5/16"	+	1/8"	+	1/32"	= 15/32"
	A130, A135	13/16"	+	1/8"	+	1/32"	= 3 1/32"
Half Surface	A211, A213, A450, A460, A520, A530, A540, A550	3/16"	+	1/8"	+	1/32"	= 1 1/32"
Full Surface	A210, A570, A571, A575	1/16"	+	1/8"	+	1/32"	= 7/32"

Single Door

Pair of Doors

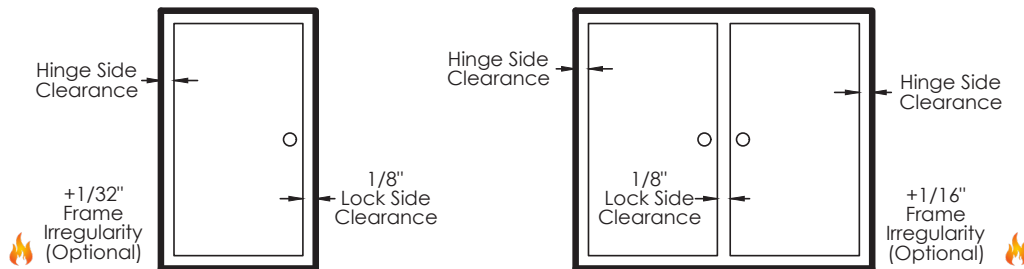

Pair of Doors - Squared Edged							
Hinge Model		Hinge Thickness (Pair)	+	Lock Side Clearance	+	*Frame Irregularity (OPTIONAL)	= Square Edged Door Undersized (Pair)
Full Concealed	A110, A110WT, A111 A111WT, A120, A140, A150, A160, A240, A260, A270, A410	5/8"	+	1/8"	+	1/16"	= 13/16"
	A130, A135	1-5/8"	+	1/8"	+	1/16"	= 1-13/16"
Half Surface	A211, A213, A450, A460, A520, A530, A540, A550	1/4"	+	1/8"	+	1/16"	= 7/16"
Full Surface	A210, A570, A571, A575	1/8"	+	1/8"	+	1/16"	= 5/16"

* 1/16" Frame Irregularity Allowance, Optional and included in all Total Door Undersize for single and pairs of doors

Frame irregularity not permitted by NFPA80

Door Clearance Chart Beveled Edge

Single Door - Beveled Edged										
Hinge Model		Hinge Thickness	+	Lock Side Clearance	+	* Frame Irregularity (OPTIONAL)	+	Beveled Door Clearance	=	Beveled Edged Door Undersized (Single)
Full Concealed	A110, A110WT, A111 A111WT, A120, A140, A150, A160, A240, A260, A270, A410	5/16"	+	1/8"	+	1/32"	+	1/32"	=	1/2"
	A130, A135	13/16"	+	1/8"	+	1/32"	+	1/32"	=	1"
Half Surface	A211, A213, A450, A460, A520, A530, A540, A550	3/16"	+	1/8"	+	1/32"	+	1/32"	=	3/8"
Full Surface	A210, A570, A571, A575	1/16"	+	1/8"	+	1/32"	+	N/A	=	7/32"

Single Door

Pair of Doors

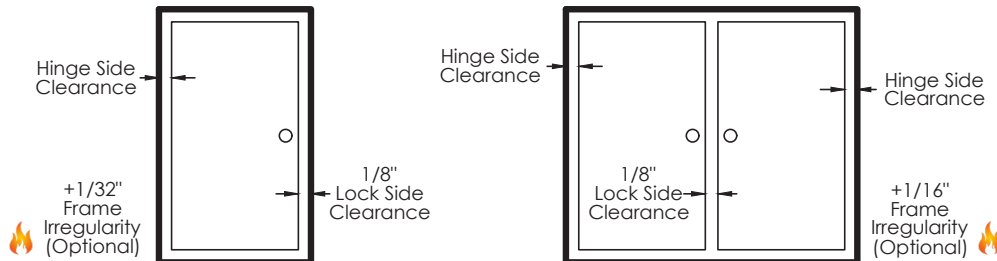

Pair of Doors - Beveled Edged										
Hinge Model		Hinge Thickness (Pair)	+	Lock Side Clearance	+	* Frame Irregularity (OPTIONAL)	+	Beveled Door Clearance	=	Beveled Edged Door Undersized (Pair)
Full Concealed	A110, A110WT, A111 A111WT, A120, A140, A150, A160, A240, A260, A270, A410	5/8"	+	1/8"	+	1/16"	+	1/16"	=	7/8"
	A130, A135	1-5/8"	+	1/8"	+	1/16"	+	1/16"	=	1-7/8"
Half Surface	A211, A213, A450, A460, A520, A530, A540, A550	1/4"	+	1/8"	+	1/16"	+	N/A	=	7/16"
Full Surface	A210, A570, A571, A575	1/8"	+	1/8"	+	1/16"	+	N/A	=	5/16"

* 1/16" Frame Irregularity Allowance, Optional and included in all Total Door Undersize for single and pairs of doors

Frame irregularity not permitted by NFPA80

INSTALLATION INSTRUCTIONS FOR HALF SURFACE HINGES

A211HD, A213HD, A450HD, A460HD, A530HD, A540HD & A550HD

- A. All uncut standard length hinges are non-handed and can be used for right or left hand doors.
- B. Standard length hinges are supplied slightly shorter than nominal door height to accommodate threshold and carpeting clearances.

CUTTING THE HINGE TO FIT

- Keep hinge in the closed position. If necessary remove door leaf caps.
- Determine **HANDING** if required.
- Cut one end of the hinge only. The hinge becomes handed after cutting and must be installed with the cut end at the bottom to keep the templated hole pattern at the top.
- Use a Metal Cutting Saw cut through the gear cap first.

Note: If cut length interferes with a set screw bearing remove it and switch it with a plain bearing above the cut location.

ATTACHING THE HINGE TO THE FRAME

With the hinge in the open position

1. Locate the top of the hinge 1/8" below the header and hold tight against the frame.
2. Mark or Center Punch hole locations: two holes at the top and two at the bottom.
3. Using the provided Flathead Self Drilling/Thread Forming Screws please proceed to fasten the frame leaf in marked holes.

Note: If using wood screws drill a 5/32" pilot hole

PREPARE THE DOOR

4. Position Door in the opening and shim for proper clearances.
5. Align the top end of the hinge to be absolutely flush with the top of the door.
6. Mark the four LOCATOR HOLE locations (shown on template) using the provided small center punch.
7. Using a #3 philips head bit, attach the door leaf to the door through the LOCATOR HOLES with the provided pan head screws
8. Remove any shims and check for proper clearances and door operation.
9. If door sags slightly, note amount of adjustment needed to bring door back into alignment.

DO NOT PROCEED UNTIL DOOR OPERATES PROPERLY

10. Locate and mark for the thru-bolts in the door using the large punch provided.
11. Remove door and use a 3/8" drill bit to drill holes at marked locations.

ATTACHING THE HINGE

12. Attached the door using the provided thru-bolts and shoulder screws

Note: Always install the shoulder screws on the secured side of the door

13. Mark or Center Punch the remaining frame leaf hole locations. Using the flathead self drilling/thread forming screws completely fasten the frame leaf.

INSTALL THE LEAF COVERS

Note: Before installing the door leaf cover make sure the the set screws do not protruded into the interior of the cover.

14. Line up the end of the door leaf cover with the top end of the hinge
15. Starting at the top, apply pressure along the length of the cover and snap into place as you go down the length of the hinge.
16. When the cover is on tighten the set screw to secure it.

Note: If using a hammer, use a block of wood to protect the cover.

REINFORCING AND RIVNUTS

- No reinforcing is necessary except on extremely high-frequency, extremely heavy or extra-wide doors.
- Rivnuts are recommended for use in the frame when the door exceeds 450lbs.

Note:RIVNUTS are **not** to be used with Fire Rated Hinges

GROUT/SLUSHED-IN FRAMES

It is recommended that a mudguard be installed behind the frame for ease of installation. Do not use self-drill screws with grouted steel frames without a mudguard. If no mudguard has been used, drill holes through frame and remove grout for screw clearances. Do not oversize hole.

SCREW DETAIL	
FRAME	12-24 x 3/4" PHILLIPS FLAT HEAD, UNDERCUT, SELF DRILLING, THREAD FORMING TEK MACHINE SCREW
DOOR	1/4-20 x 1-1/4" x 3/8 DIA. SEX BOLT & 1/4-20 x 1-1/4" PH. HEAD SHOULDER SCREW
	12-24 x 1" PH. PN. HD. SELF DRILLING TEK SCREW (LOCATOR HOLE)

Note: #12 x 1-1/2" FLAT HEAD UNDERCUT WOOD SCREWS AVAILABLE UPON REQUEST

The following actions will void any warranty, expressed or implied.

- Failure to Install the hinge according to ABH's specifications and requirements
- Use of Fasteners other than those supplied with the hinge.
- Unauthorized field modifications including removing any of the bearings, altering the original finish or painting the hinge.



www.abhmfg.com
E-mail: abhinfo@abhmfg.com
Architectural Builders Hardware Mfg., Inc.
1222 Ardmore Ave., Itasca, IL 60143
630.875.9900; FAX 800.9FAXABH (932.9224)

© 2020 ABH Mfg., Inc.
printed in USA

HS INSTALLATION-05.DWG
HALF SURFACE
INSTALLATION
INSTRUCTIONS
PAGE 1 OF 1
REVISED 10/15/20



ABH Manufacturing Inc.
1222 Ardmore Avenue
Itasca, IL 60143
Ph: (630)875-9900 Fax: (800) 932-9224
www.abhmfg.com

ANSI/BHMA A156.26-2017 Certified Continuous Hinges

Edge Mounted-Barrel Type-Stainless Steel-Grade 1

ABH Model Number(s): A500, A505, A515

Edge Mounted-Gear Type-Aluminum-Grade 1

ABH Model Number(s): A110(HD/LL), A110WT(HD/LL), A111(HD/LL),
A111WT(HD/LL), A130HD, A140(HD/LL), A150(HD/LL), A160(HD/LL),
A240(HD/LL), A260(HD/LL), A270(HD/LL), A410(HD/LL)

Full Surface Mounted-Barrel Type-Stainless Steel-Grade 1

ABH Model Number(s): A502, A512

Full Surface Mounted- Gear Type- Aluminum-Grade 1

ABH Model Number(s): A210HD, A570HD, A571HD

Half-Surface Mounted-Barrel Type-Stainless Steel-Grade 1

ABH Model Number(s): A503

Half-Surface Mounted- Gear Type- Aluminum-Grade 1

ABH Model Number(s): A211HD, A213HD, A450HD, A460HD, A530HD, A540HD,
A550HD

Half Mortise Mounted-Barrel Type-Stainless Steel-Grade 1

ABH Model Number(s): A504, A506

Half Mortise Mounted- Gear Type- Aluminum-Grade 1

ABH Model Number(s): A520HD

Swing Clear Edge Mounted-Barrel Type-Stainless Steel-Grade 1

ABH Model Number(s): A510, A511, A526, A529

Swing Clear Edge Mounted- Gear Type- Aluminum-Grade 1

ABH Model Number(s): A410(HD/LL), A211HD

HD-denotes Heavy Duty Hinge

LL-denotes Heavy Duty hinge with extra screw holes to accommodate the lead in lead lined doors