

**Advanced Hospital Tips  
Full Surface**

**A570**

ABH Advanced Hospital Tips (AHT) are designed for use in behavioral health facilities, hospitals, correctional facilities or any institution where there are ligature risks. While most hospital tips are designed to work only in the closed position, the AHT works whether the hinge is open or closed. Each AHT has been designed to work with the specific hinge needed for the door and frame application at hand.



Possible ligature points present without the use of Hospital Tips

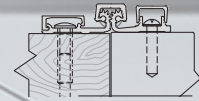

Ligature points eliminated with the use of Hospital Tips

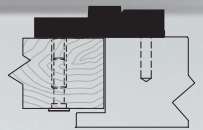

Possible ligature points present without the use of Hospital Tips

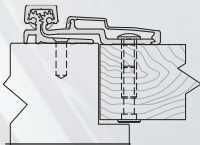

Ligature points eliminated with the use of Hospital Tips

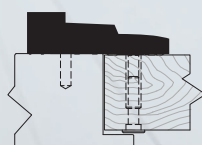

**A210**



\*Note: Thickness of the door must be specified before ordering hinges.

## Full Surface

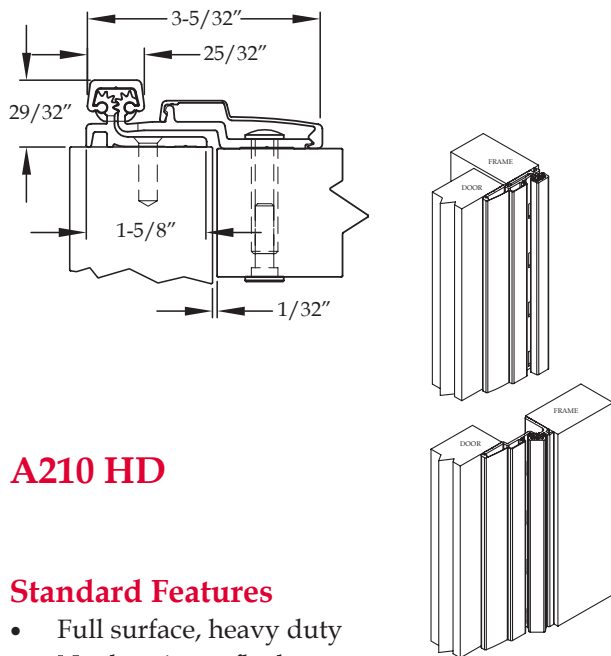

### A210 HD

#### Standard Features

- Full surface, heavy duty
- No door inset, flush mount
- Swing clear application
- 48" door width maximum
- 450 lbs. door weight maximum
- **Fasteners:** 12-24 x 7/8" undercut self-drilling, thread-forming tek machine screws for frame and 1/4-20 sex bolts and shoulder bolts for door
- **Standard lengths:** 79", 83", 85", 95" and 120"
- **Finishes:** Clear, dark bronze and black anodized
- **Fire Rating**
  - Approved for use on metal swinging type fire doors rated up to and including 90 minutes (Specify "FR" option for 3 hour rating)
  - Approved for use on wood swinging type fire doors rated up to and including 60 minutes (Specify "FR" option for 90 minute rating)

#### Options Available

- See pages F-7 to F-8 for option availability and details

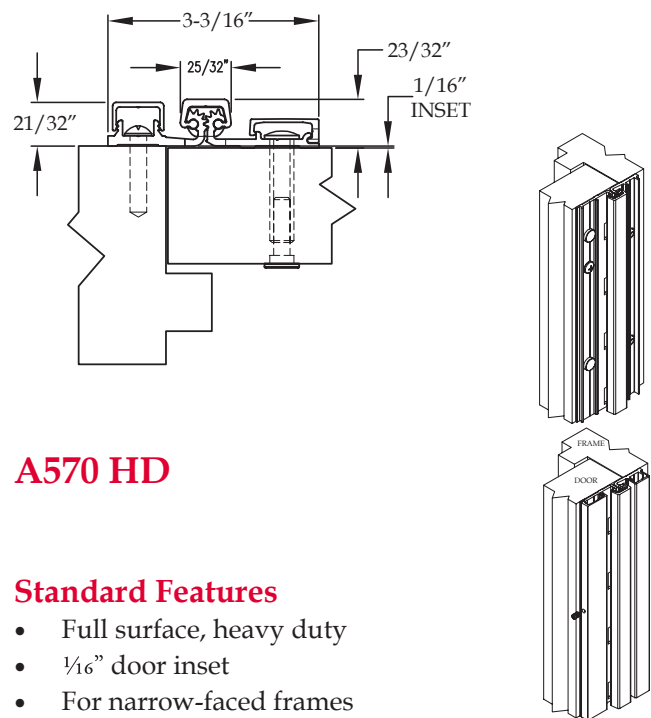

### A570 HD

#### Standard Features

- Full surface, heavy duty
- 1/16" door inset
- For narrow-faced frames
- 48" door width maximum
- 450 lbs. door weight maximum
- **Fasteners:** 12-24 x 7/8" undercut self-drilling, thread-forming tek machine screws for frame and 1/4-20 sex bolts and shoulder bolts for door
- **Standard lengths:** 79", 83", 85", 95" and 120"
- **Finishes:** Clear, dark bronze and black anodized
- **Fire Rating**
  - Approved for use on metal swinging type fire doors rated up to and including 90 minutes (Specify "FR" option for 3 hour rating)
  - Approved for use on wood swinging type fire doors rated up to and including 60 minutes (Specify "FR" option for 90 minute rating)

#### Options Available

- See pages F-7 to F-8 for option availability and details



# INSTALLATION INSTRUCTIONS FOR FULL SURFACE HINGES

## A210HD, A570HD & A571HD

- A. All uncut standard length hinges are non-handed and can be used for right or left hand doors.
- B. Standard length hinges are supplied slightly shorter than nominal door height to accommodate threshold and carpeting clearances.

### CUTTING THE HINGE TO FIT

- Keep hinge in the closed position. If necessary remove door/frame leaf caps.
- Cut one end of the hinge only. The hinge must be installed with the cut end at the bottom to keep the templated hole pattern at the top.
- Use a Metal Cutting Saw cut through the gear cap first.

**Note:** If cut length interferes with a set screw bearing remove it and switch it with a plain bearing above the cut location.

### ATTACHING THE HINGE TO THE FRAME

1. Shim the hinge to be 1/8" below the header.
2. Hold hinge in the open position and align frame leaf with the inner edge of the door frame.
3. Mark or Center Punch hole locations: two holes at the top and two at the bottom.
4. Using the provided Self Drilling/Thread Forming Screws please proceed to fasten the frame leaf in marked holes.

**Note:** If using wood screws drill a 5/32" pilot hole.

### PREPARE THE DOOR

5. Position Door in the opening and shim for proper clearances.
6. Align the top end of the hinge to be absolutely flush with the top of the door.
7. Mark the four LOCATOR HOLE locations (shown on template) using the provided small center punch.
8. Using a #3 philips head bit, attach the door leaf to the door through the LOCATOR HOLES with the provided pan head screws
9. Remove any shims and check for proper clearances and door operation.
10. If door sags slightly, note amount of adjustment needed to bring door back into alignment.

#### **DO NOT PROCEED UNTIL DOOR OPERATES PROPERLY**

11. Locate and mark for the thru-bolts in the door using the large punch provided.
12. Remove door and use a 3/8" drill bit to drill holes at marked locations

### ATTACHING DOOR TO THE HINGE

13. Fasten the door to door leaf using the provided sex bolts and shoulder screws

**Note:** Always install the shoulder screws on the secured side of the door

14. Mark or Center Punch the remaining frame leaf hole locations. Using the provided flathead or pan head self drilling/thread forming screws completely fasten the frame leaf.

### INSTALL THE LEAF COVERS

**Note:** Before installing the door leaf cover make sure the the set screws do not protruded into the interior of the cover.

15. Line up the end of the door leaf cover with the top end of the hinge
16. Starting at the top, apply pressure along the length of the cover and snap into place as you go down the length of the hinge.
17. When the cover is on tighten the set screw to secure it.
18. Install the frame leaf cover by first hooking it onto the outside edge of the frame leaf.
19. Starting at the top, apply pressure along the length of the cover and snap into place as you go down the length of the hinge.

**Note:** If using a hammer, use a block of wood to protect the cover.

### REINFORCING AND RIVNUTS

- No reinforcing is necessary except on extremely high-frequency, extremely heavy or extra-wide doors.
- Rivnuts are recommended for use in the frame when the door exceeds 450lbs.

**Note:** RIVNUTS are **not** to be used with Fire Rated Hinges

### GROUT/SLUSHED-IN FRAMES

It is recommended that a mudguard be installed behind the frame for ease of installation. Do not use self-drill screws with grouted steel frames without a mudguard. If no mudguard has been used, drill holes through frame and remove grout for screw clearances. Do not oversize hole.

SCREW DETAIL	
FRAME	12-24 x 3/4" PHILLIPS FLAT HEAD, UNDERCUT, SELF DRILLING, THREAD FORMING TEK MACHINE SCREW
FRAME	12-24 x 1" PHILLIPS PAN HEAD, SELF DRILLING, THREAD FORMING TEK MACHINE SCREW
DOOR	1/4-20 x 1-1/4" x 3/8 DIA. SEX BOLT & 1/4-20 x 1-1/4" PH. HEAD SHOULDER SCREW
	12-24 x 1" PH. PN. HD. SELF DRILLING TEK SCREW (LOCATOR HOLE)

The following actions will void any warranty, expressed or implied.

- Failure to Install the hinge according to ABH's specifications and requirements
- Use of Fasteners other than those supplied with the hinge.
- Unauthorized field modifications including removing any of the bearings, altering the original finish or painting the hinge.



www.abhmfg.com  
E-mail: abhinfo@abhmfg.com  
Architectural Builders Hardware Mfg., Inc.  
1222 Ardmore Ave., Itasca, IL 60143  
630.875.9900; FAX 800.9FAXABH (932.9224)

© 2020 ABH Mfg., Inc.  
printed in USA

FS INSTALLATION-05.DWG  
FULL SURFACE  
INSTALLATION  
INSTRUCTIONS  
PAGE 1 OF 1  
REVISED 1-27-21

# A210 - ALUMINUM GEARED HINGE, SWING CLEAR, NO INSET, FULL SURFACE

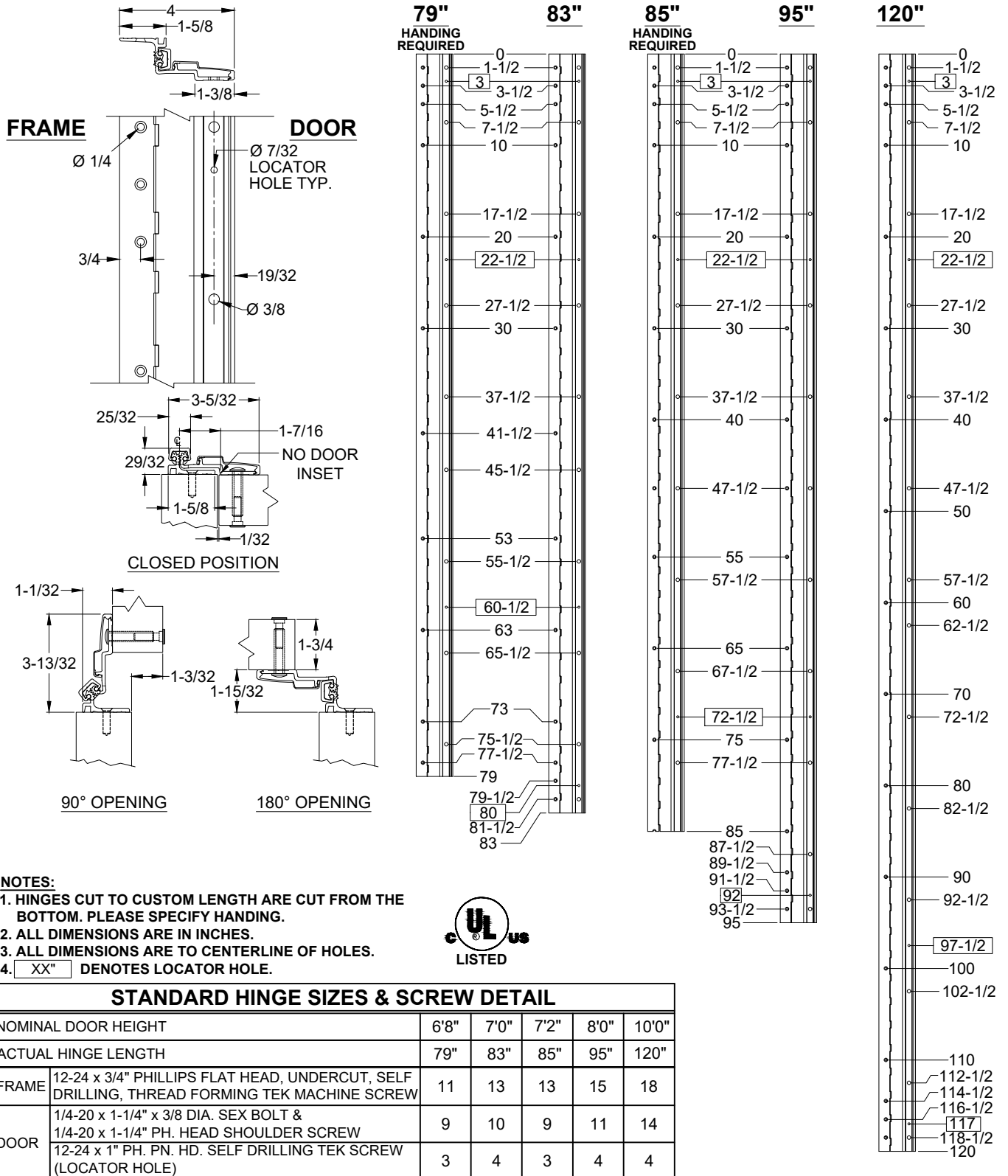

A210-ALUMINUM GEARED HINGE-02.DWG



www.abhmf.com  
 E-mail: abhinfo@abhmf.com  
 Architectural Builders Hardware Mfg., Inc.  
 1222 Ardmore Ave., Itasca, IL 60143  
 630.875.9900; FAX 800.9FAXABH (932.9224)

© 2020 ABH Mfg., Inc.  
 printed in USA

**A210**  
ALUMINUM GEARED HINGE

PAGE 1 OF 1  
 REVISED 9-10-20

**A210 - "AHT" OPTION, ADVANCED HOSPITAL TIP, ALUMINUM GEARED HINGE, SWING CLEAR, NO INSET, FULL SURFACE**

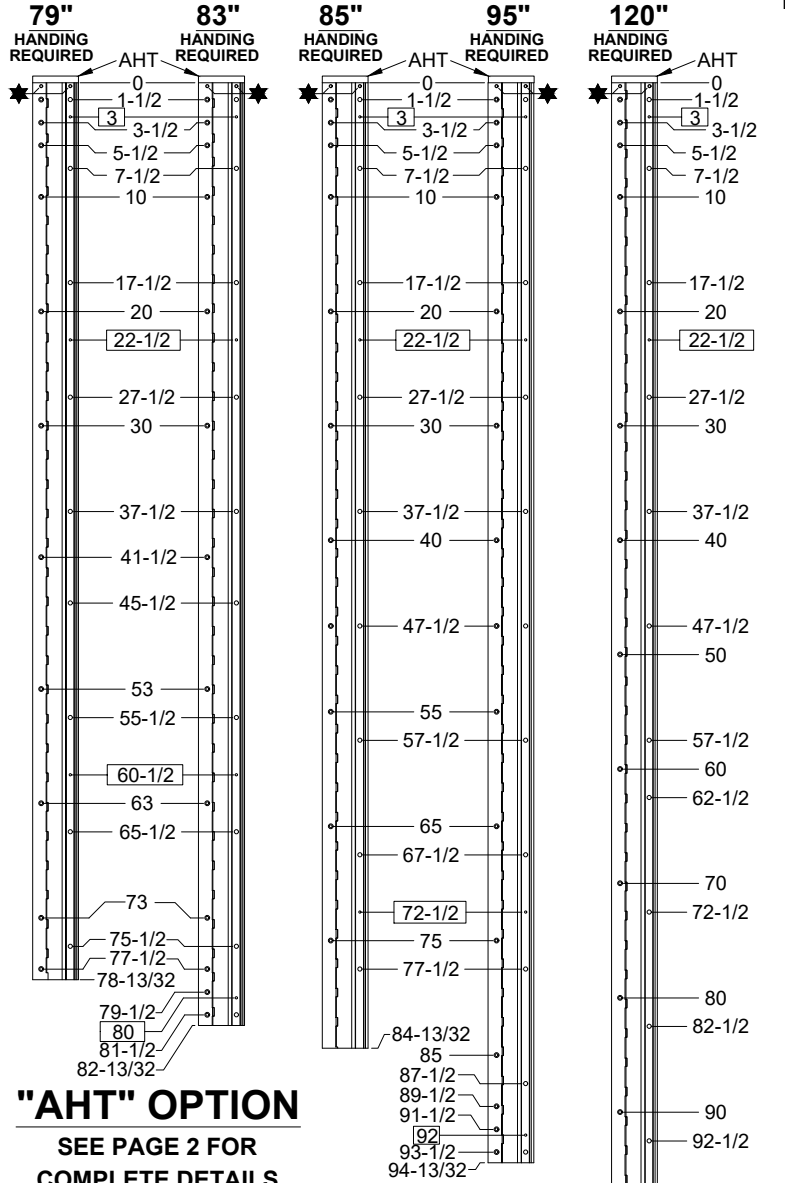
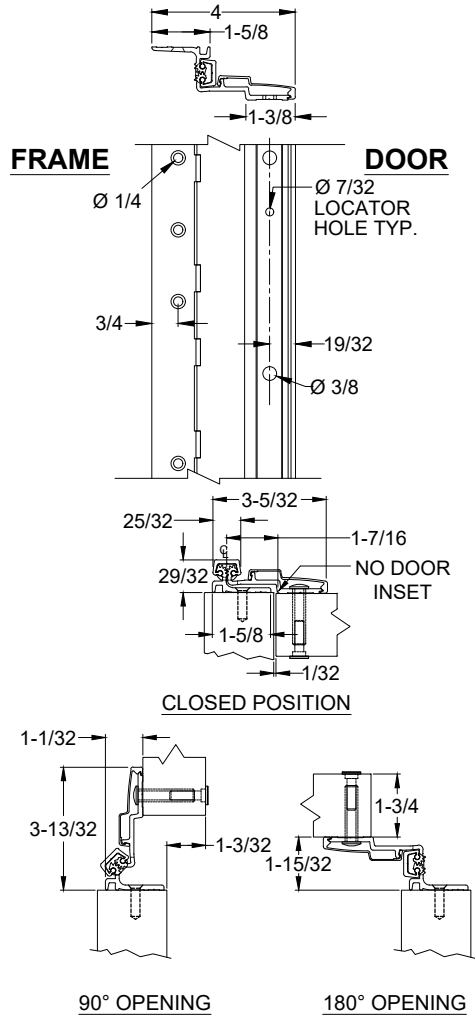

**"AHT" OPTION**  
SEE PAGE 2 FOR COMPLETE DETAILS

- NOTES:**
- HINGES CUT TO CUSTOM LENGTH ARE CUT FROM THE BOTTOM. PLEASE SPECIFY HANDING.
  - ALL DIMENSIONS ARE IN INCHES.
  - ALL DIMENSIONS ARE TO CENTERLINE OF HOLES.
  - XX" DENOTES LOCATOR HOLE.
- ★ = ADVANCED HOSPITAL TIP (AHT), AT THE TOP OF THE HINGE PER HANDING. MANUFACTURING TO ADD (2) .234 (15/64") DIA. THRU HOLES FOR #12 SCREWS SEE DETAIL TO THE RIGHT. SEE INSTALLATION PAGE 2.

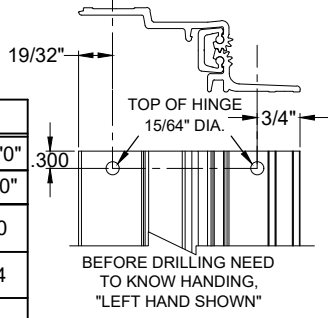

STANDARD HINGE SIZES & SCREW DETAIL						
NOMINAL DOOR HEIGHT	6'8"	7'0"	7'2"	8'0"	10'0"	
ACTUAL HINGE LENGTH	79"	83"	85"	95"	120"	
FRAME	12-24 x 3/4" PHILLIPS FLAT HEAD, UNDERCUT, SELF DRILLING, THREAD FORMING TEK MACHINE SCREW	13	15	15	17	20
DOOR	1/4-20 x 1-1/4" x 3/8 DIA. SEX BOLT & 1/4-20 x 1-1/4" PH. HEAD SHOULDER SCREW	9	10	9	11	14
	12-24 x 1" PH. PN. HD. SELF DRILLING TEK SCREW (LOCATOR HOLE)	3	4	3	4	4
	#12 x 1-1/2" PHILLIPS FLAT HEAD UNDERCUT SHEET METAL SCREW	2	2	2	2	2



www.abhmfg.com  
E-mail: abhinfo@abhmfg.com  
Architectural Builders Hardware Mfg., Inc.  
1222 Ardmore Ave., Itasca, IL 60143  
630.875.9900; FAX 800.9FAXABH (932.9224)

A210-AHT OPTION, ADVANCED HOSPITAL TIP-1-01.DWG  
**A210 - "AHT" OPTION**  
ADVANCED HOSPITAL TIP  
PAGE 1 OF 2  
REVISED 8-11-21  
© 2019 ABH Mfg., Inc.  
printed in USA

# A210 - "AHT" OPTION, ADVANCED HOSPITAL TIP, ALUMINUM GEARED HINGE, SWING CLEAR, NO INSET, FULL SURFACE

## A210 AHT (ADVANCED HOSPITAL TIP) INSTALLATION INSTRUCTIONS

1. INSTALL TOP OF HINGE 19/32" FROM THE TOP OF THE DOOR
2. BEFORE INSTALLING DOOR LEAF COVER, INSTALL FRAME AND THEN DOOR SIDE HOSPITAL TIP SECTIONS
3. INSTALL FRAME SIDE AHT SECTION
  - a. SLIDE AHT SECTION OVER HINGE LEAF, THIS WILL LINE UP WITH THE PREDRILLED HINGE LEAF THRU-HOLE
  - b. FOR METAL FRAMES, MARK HOLE LOCATION, THEN DRILL AND FASTEN THE AHT SECTION USING PROVIDED 12-24 X 7/8" PH FLAT HEAD, UNDERCUT, SELF-DRILLING, THREAD FORMING TEK MACHINE SCREW
  - c. FOR WOOD FRAMES, MARK HOLE LOCATION AND DRILL 3/16" PILOT HOLE, FASTEN AHT SECTION USING PROVIDED #12 X 1-1/2" PH FLAT HEAD, UNDERCUT WOOD SCREW
4. INSTALL DOOR SIDE AHT SECTION
  - a. SLIDE AHT SECTION INTO SLOT ON HINGE LEAF, THIS WILL LINE UP WITH THE PREDRILLED HINGE LEAF THRU-HOLE
  - b. FOR METAL DOORS, MARK HOLE LOCATION, THEN DRILL AND FASTEN THE AHT SECTION USING PROVIDED 12-24 X 7/8" PH FLAT HEAD, UNDERCUT, SELF-DRILLING, THREAD FORMING TEK MACHINE SCREW
  - c. FOR WOOD DOORS, MARK HOLE LOCATION AND DRILL 3/16" PILOT HOLE, FASTEN AHT SECTION USING PROVIDED #12 X 1-1/2" PH FLAT HEAD, UNDERCUT WOOD SCREW
5. BEFORE TIGHTENING THE SCREWS DOWN COMPLETELY, DOOR AND FRAME AHT SECTIONS SHOULD BE FLUSH WITH THE TOP OF THE DOOR.
6. INSTALL DOOR LEAF COVER.

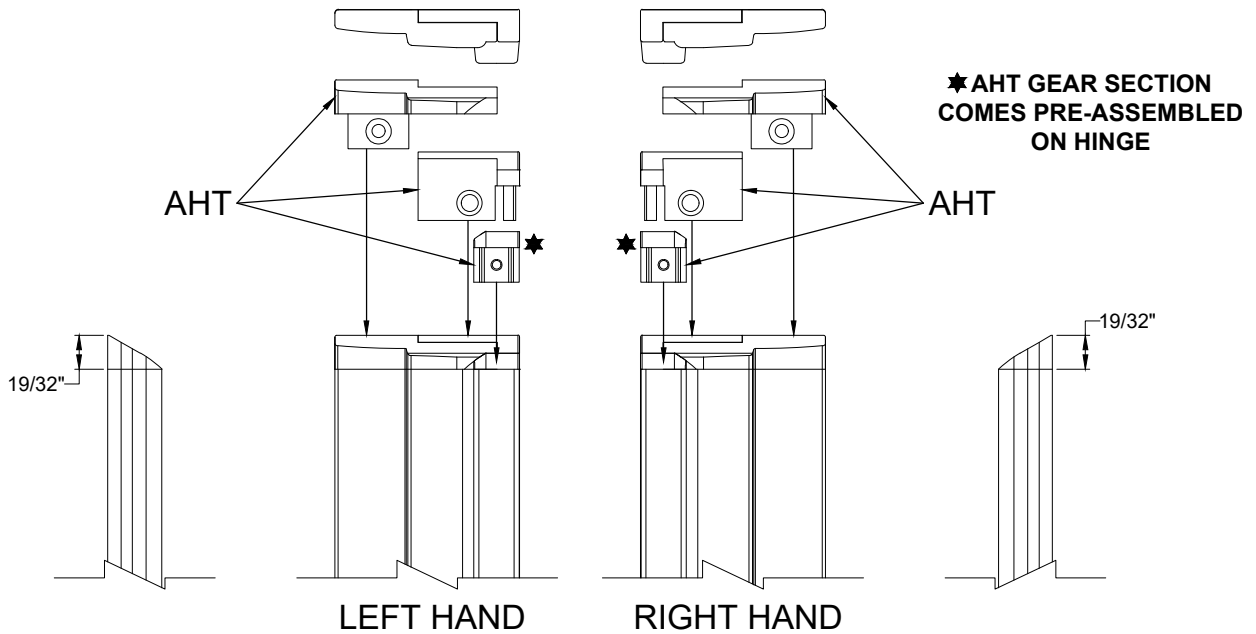

A210-AHT OPTION, ADVANCED HOSPITAL TIP-2-01.DWG

**ABH**  
MANUFACTURING INC.

www.abhmfg.com  
E-mail: abhinfo@abhmfg.com  
Architectural Builders Hardware Mfg., Inc.  
1222 Ardmore Ave., Itasca, IL 60143  
630.875.9900; FAX 800.9FAXABH (932.9224)

© 2019 ABH Mfg., Inc.  
printed in USA

**A210 - "AHT" OPTION**  
ADVANCED HOSPITAL TIP

PAGE 2 OF 2  
REVISED 8-11-21