

## Half Surface

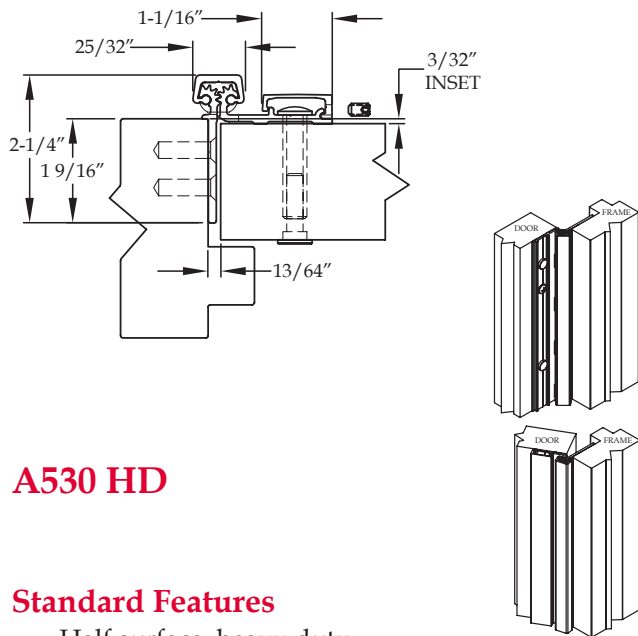

### A530 HD

#### Standard Features

- Half surface, heavy duty
- $\frac{3}{32}$ " door inset
- 48" door width maximum
- 450 lbs. door weight maximum
- **Fasteners:** 12-24 x  $\frac{7}{8}$ " undercut self-drilling, thread-forming tek machine screws for frame and  $\frac{1}{4}$ -20 sex bolts and shoulder bolts for door
- **Standard lengths:** 79", 83", 85", 95" and 120"
- **Finishes:** Clear, dark bronze and black anodized
- **Fire Rating**
  - Approved for use on metal swinging type fire doors rated up to and including 90 minutes (Specify "FR" option for 3 hour rating)
  - Approved for use on wood swinging type fire doors rated up to and including 60 minutes (Specify "FR" option for 90 minute rating)

#### Options Available

- See pages F-7 to F-8 for option availability and details

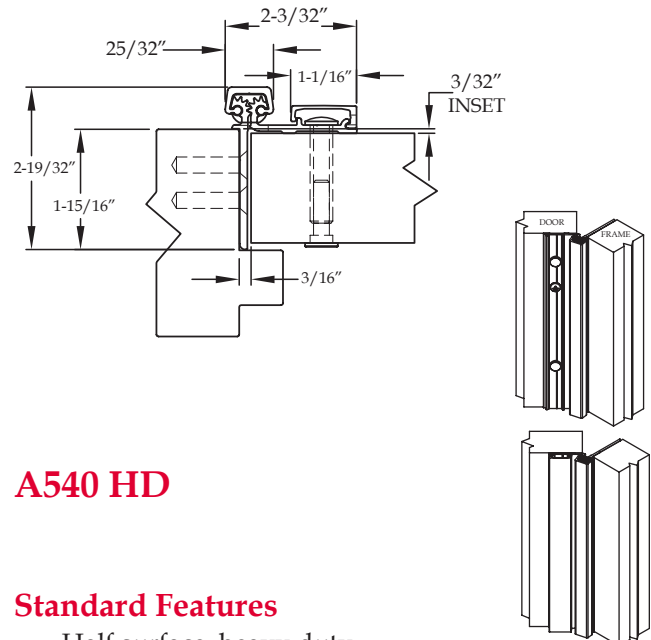

### A540 HD

#### Standard Features

- Half surface, heavy duty
- $\frac{3}{32}$ " door inset
- 48" door width maximum
- 450 lbs. door weight maximum
- **Fasteners:** 12-24 x  $\frac{7}{8}$ " undercut self-drilling, thread-forming tek machine screws for frame and  $\frac{1}{4}$ -20 sex bolts and shoulder bolts for door
- **Standard lengths:** 79", 83", 85", 95" and 120"
- **Finishes:** Clear, dark bronze and black anodized
- **Fire Rating**
  - Approved for use on metal swinging type fire doors rated up to and including 90 minutes (Specify "FR" option for 3 hour rating)
  - Approved for use on wood swinging type fire doors rated up to and including 60 minutes (Specify "FR" option for 90 minute rating)

#### Options Available

- See pages F-7 to F-8 for option availability and details



# INSTALLATION INSTRUCTIONS FOR HALF SURFACE HINGES

## A211HD, A213HD, A450HD, A460HD, A530HD, A540HD & A550HD

- A. All uncut standard length hinges are non-handed and can be used for right or left hand doors.
- B. Standard length hinges are supplied slightly shorter than nominal door height to accommodate threshold and carpeting clearances.

### CUTTING THE HINGE TO FIT

- Keep hinge in the closed position. If necessary remove door leaf caps.
- Determine **HANDING** if required.
- Cut one end of the hinge only. The hinge becomes handed after cutting and must be installed with the cut end at the bottom to keep the templated hole pattern at the top.
- Use a Metal Cutting Saw cut through the gear cap first.

**Note:** If cut length interferes with a set screw bearing remove it and switch it with a plain bearing above the cut location.

### ATTACHING THE HINGE TO THE FRAME

With the hinge in the open position

1. Locate the top of the hinge 1/8" below the header and hold tight against the frame.
2. Mark or Center Punch hole locations: two holes at the top and two at the bottom.
3. Using the provided Flathead Self Drilling/Thread Forming Screws please proceed to fasten the frame leaf in marked holes.

**Note:** If using wood screws drill a 5/32" pilot hole

### PREPARE THE DOOR

4. Position Door in the opening and shim for proper clearances.
5. Align the top end of the hinge to be absolutely flush with the top of the door.
6. Mark the four LOCATOR HOLE locations (shown on template) using the provided small center punch.
7. Using a #3 philips head bit, attach the door leaf to the door through the LOCATOR HOLES with the provided pan head screws
8. Remove any shims and check for proper clearances and door operation.
9. If door sags slightly, note amount of adjustment needed to bring door back into alignment.

#### **DO NOT PROCEED UNTIL DOOR OPERATES PROPERLY**

10. Locate and mark for the thru-bolts in the door using the large punch provided.
11. Remove door and use a 3/8" drill bit to drill holes at marked locations.

### ATTACHING THE HINGE

12. Attached the door using the provided thru-bolts and shoulder screws

**Note:** Always install the shoulder screws on the secured side of the door

13. Mark or Center Punch the remaining frame leaf hole locations. Using the flathead self drilling/thread forming screws completely fasten the frame leaf.

### INSTALL THE LEAF COVERS

**Note:** Before installing the door leaf cover make sure the the set screws do not protruded into the interior of the cover.

14. Line up the end of the door leaf cover with the top end of the hinge
15. Starting at the top, apply pressure along the length of the cover and snap into place as you go down the length of the hinge.
16. When the cover is on tighten the set screw to secure it.

**Note:** If using a hammer, use a block of wood to protect the cover.

### REINFORCING AND RIVNUTS

- No reinforcing is necessary except on extremely high-frequency, extremely heavy or extra-wide doors.
- Rivnuts are recommended for use in the frame when the door exceeds 450lbs.

**Note:**RIVNUTS are **not** to be used with Fire Rated Hinges

### GROUT/SLUSHED-IN FRAMES

It is recommended that a mudguard be installed behind the frame for ease of installation. Do not use self-drill screws with grouted steel frames without a mudguard. If no mudguard has been used, drill holes through frame and remove grout for screw clearances. Do not oversize hole.

SCREW DETAIL	
FRAME	12-24 x 3/4" PHILLIPS FLAT HEAD, UNDERCUT, SELF DRILLING, THREAD FORMING TEK MACHINE SCREW
DOOR	1/4-20 x 1-1/4" x 3/8 DIA. SEX BOLT & 1/4-20 x 1-1/4" PH. HEAD SHOULDER SCREW
	12-24 x 1" PH. PN. HD. SELF DRILLING TEK SCREW (LOCATOR HOLE)

**Note:** #12 x 1-1/2" FLAT HEAD UNDERCUT WOOD SCREWS AVAILABLE UPON REQUEST

The following actions will void any warranty, expressed or implied.

- Failure to Install the hinge according to ABH's specifications and requirements
- Use of Fasteners other than those supplied with the hinge.
- Unauthorized field modifications including removing any of the bearings, altering the original finish or painting the hinge.



www.abhmfg.com  
E-mail: abhinfo@abhmfg.com  
Architectural Builders Hardware Mfg., Inc.  
1222 Ardmore Ave., Itasca, IL 60143  
630.875.9900; FAX 800.9FAXABH (932.9224)

© 2020 ABH Mfg., Inc.  
printed in USA

HS INSTALLATION-05.DWG  
HALF SURFACE  
INSTALLATION  
INSTRUCTIONS  
PAGE 1 OF 1  
REVISED 10/15/20

# A530 - ALUMINUM GEARED HINGE, 3/32" INSET, HALF SURFACE

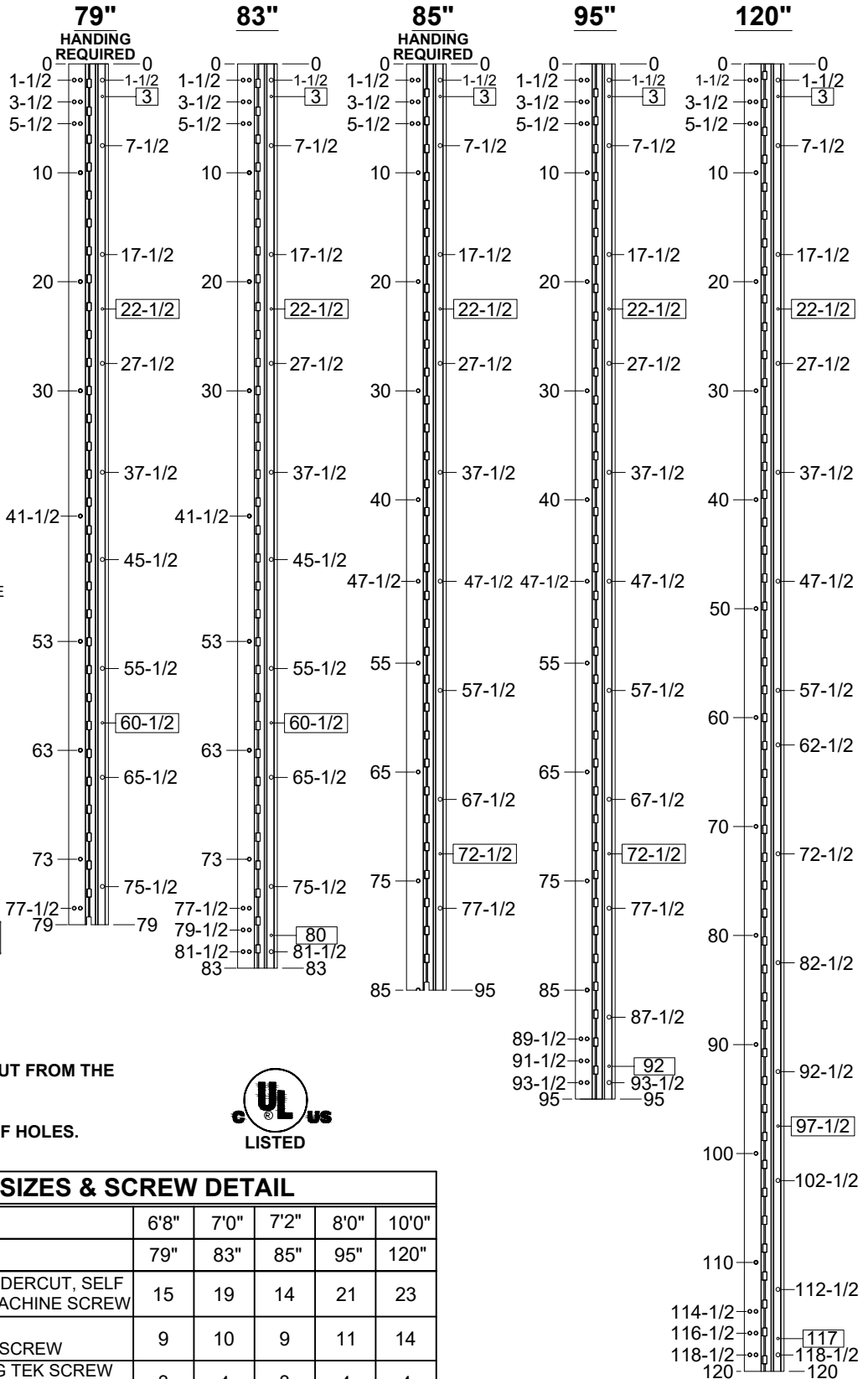
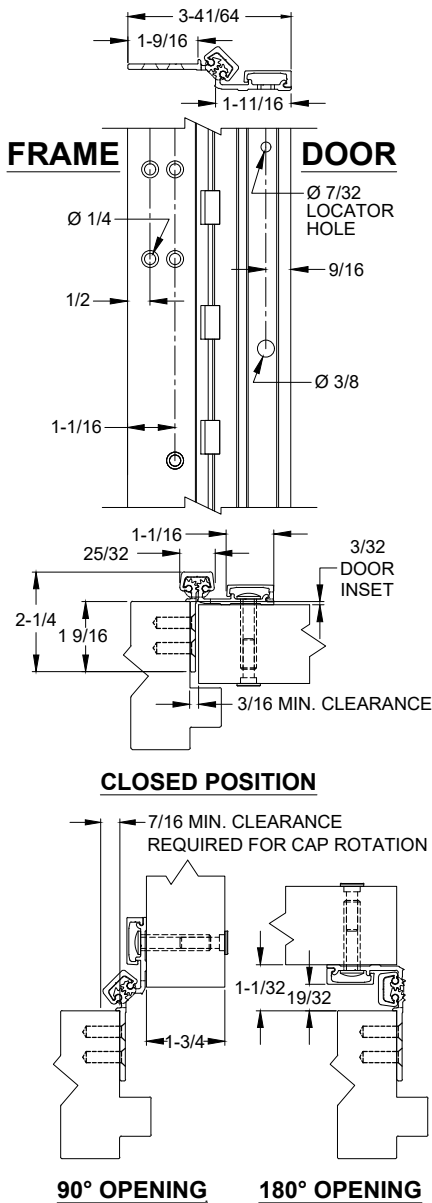

**NOTES:**

1. HINGES CUT TO CUSTOM LENGTH ARE CUT FROM THE BOTTOM. PLEASE SPECIFY HANDING.
2. ALL DIMENSIONS ARE IN INCHES.
3. ALL DIMENSIONS ARE TO CENTERLINE OF HOLES.
4. XX DENOTES LOCATOR HOLE.



**STANDARD HINGE SIZES & SCREW DETAIL**

NOMINAL DOOR HEIGHT		6'8"	7'0"	7'2"	8'0"	10'0"
ACTUAL HINGE LENGTH		79"	83"	85"	95"	120"
FRAME	12-24 x 3/4" PHILLIPS FLAT HEAD, UNDERCUT, SELF DRILLING, THREAD FORMING TEK MACHINE SCREW	15	19	14	21	23
DOOR	1/4-20 x 1-1/4" x 3/8 DIA. SEX BOLT & 1/4-20 x 1-1/4" PH. HEAD SHOULDER SCREW	9	10	9	11	14
	12-24 x 1" PH. PN. HD. SELF DRILLING TEK SCREW (LOCATOR HOLE)	3	4	3	4	4

A530-ALUMINUM GEARED HINGE-03.DWG



www.abhmfg.com  
 E-mail: abhinfo@abhmfg.com  
 Architectural Builders Hardware Mfg., Inc.  
 1222 Ardmore Ave., Itasca, IL 60143  
 630.875.9900; FAX 800.9FAXABH (932.9224)

© 2019 ABH Mfg., Inc.  
 printed in USA

**A530**  
**ALUMINUM GEARED HINGE**

PAGE 1 OF 1  
 REVISED 9-10-20