

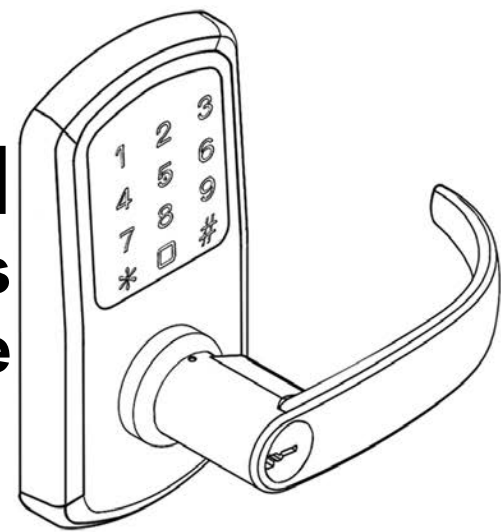

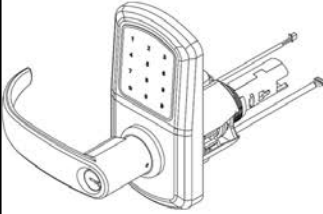







TownSteel **e-Elite Touch Keypad Series** **Installation Guide**

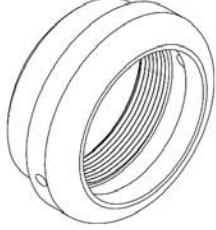
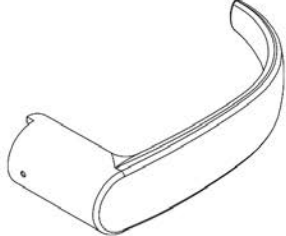
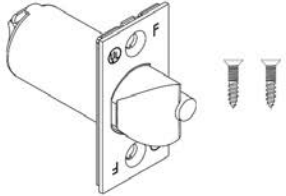
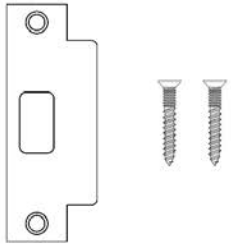

Package Content	2
Getting Started	3
Door Preparation	4
Step 1 - Latch Bolt & Strike	5
Step 2 - Installing Outside Assembly	6
Step 3 - Installing Backplate	7
Step 4 - Connecting Wires	8
Step 5 - Installing Inside Assembly	9
Step 6 - Installing Covers	10
Step 7 - Installing Inside Lever	11
Addendum	12
Exploded View	13
Troubleshoot	14

Package Content

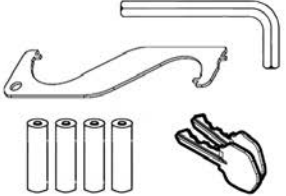
Parts in the box			
Outside Assembly 	Backplate 	Inside Assembly 	Inside Lower Cover 
Inside Upper Cover 	Collar 	Bearing Ring 	Inside Lever 
Latch Bolt & Screws 	Strike & Screws 	Backplate Screws  Inside Assembly Screws  Inside Cover Screw 	Additional Parts Included 

Getting Started

Tools needed for lock installation

Phillips Screw Driver (Not included)

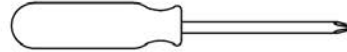

Lever Removal Tool



Torx Wrench



Note:

Do not use a power drill for installation of lock - it can damage the lock.

Handing Information

If hinges are on the right,
and the door opens inward,
it is a **right hand door (RH)**



If hinges are on the right,
and the door opens outward,
it is a **right hand reverse door (RHR)**



If hinges are on the left,
and the door opens inward,
it is a **left hand door (LH)**



If hinges are on the left,
and the door opens outward,
it is a **left hand reverse door (LHR)**



Door Preparation

Prepare door and jamb per template provided. The backset is the dimension from the edge of the door to the centerline of the lock.

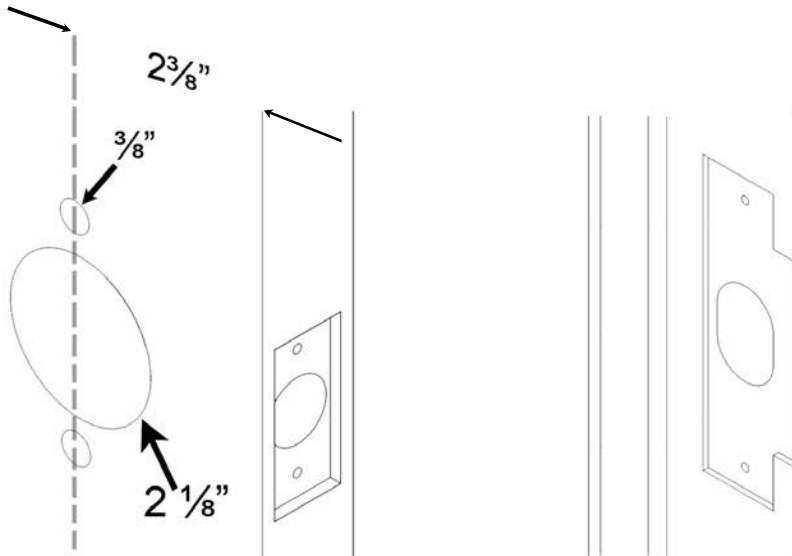

Important:

Door stop is where the door will stop when normally operated. The stop includes any gasket, smoke seal, or bumpers. The position of strikes are to be measured taking this into account.

Step 1

Install the latch bolt and secure with 2 screws. Install strike and secure with 2 screws.

Note: A right hand (RH) lock will be depicted in the following guide - for left hand (LH) install opposite. During installation keep the door open. Do not use power tools for assembly or you can potentially damage the door.

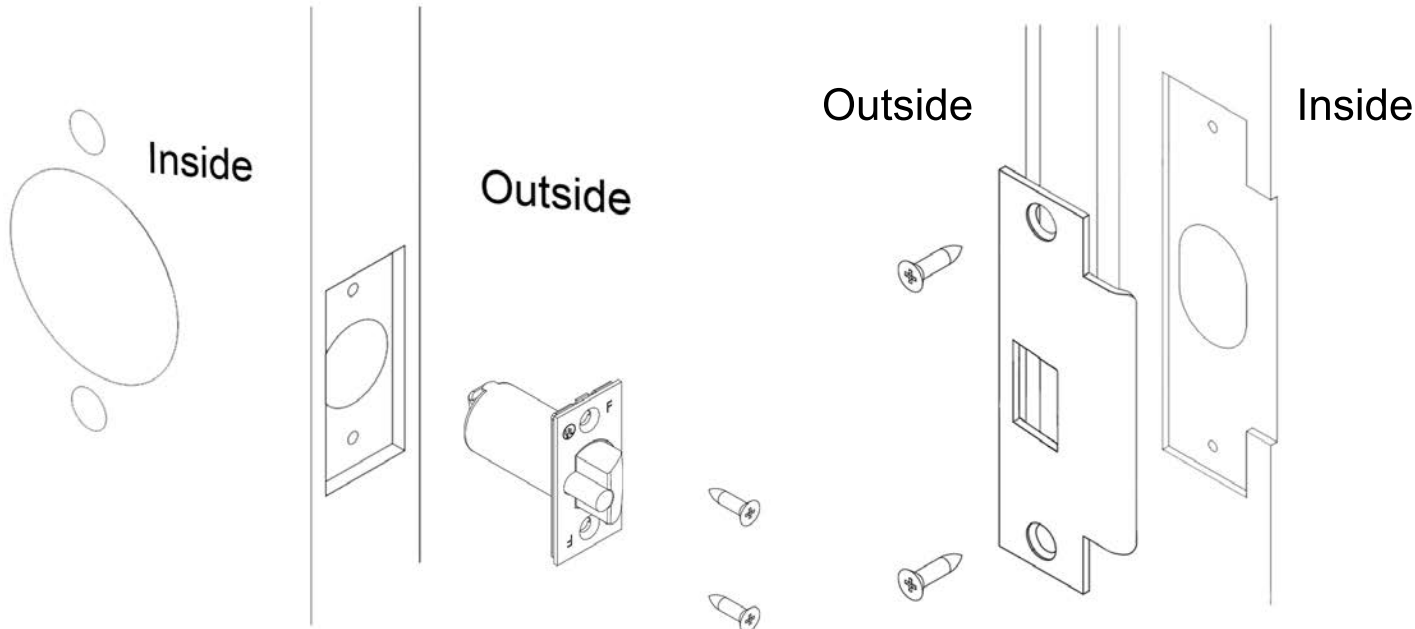

Step 2

Install the outside lock assembly in the cutout. Guide the wire harnesses through the cutout. Line up the retractor on the lock body with the latch tail piece. Tighten the latch screws.

Note: Do not pull or pinch the wire harnesses.

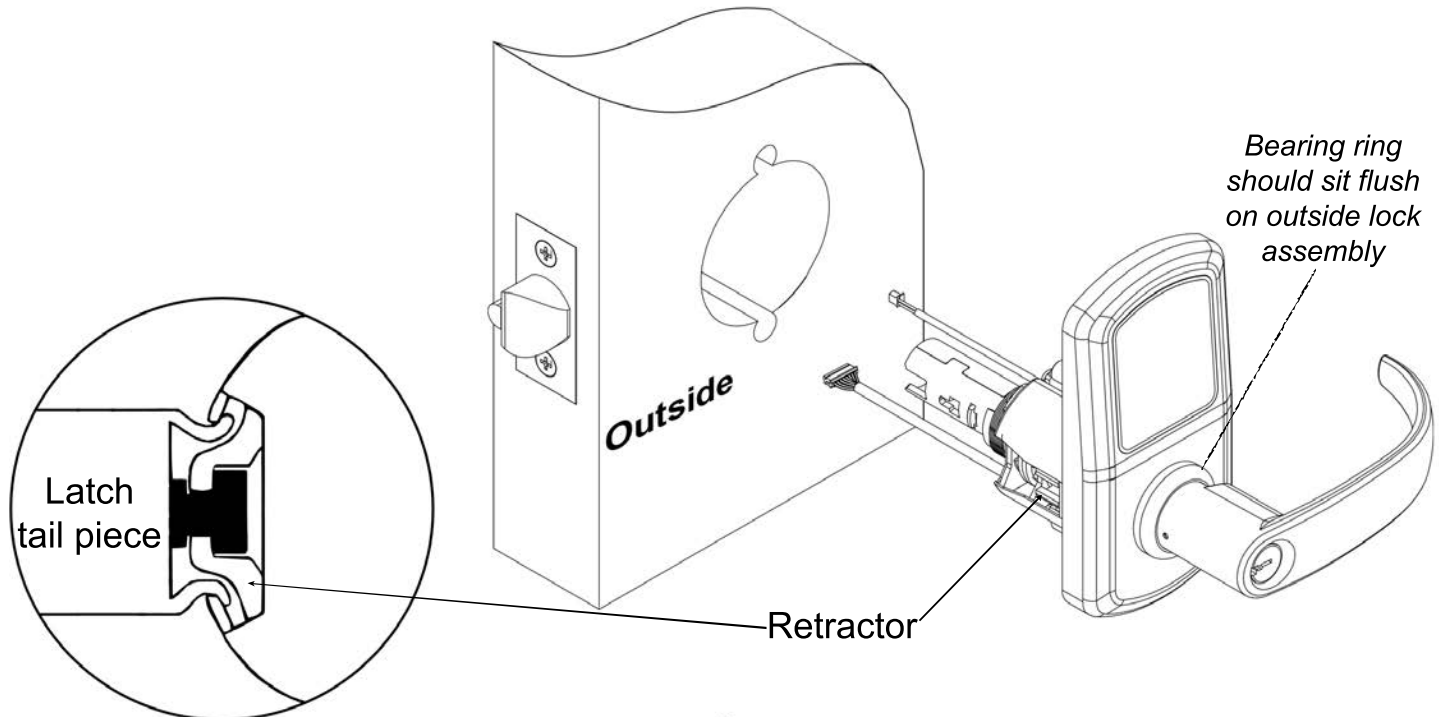

Step 3

Install the backplate on the inside. Make sure to route the wire harnesses through the cutout shown. Secure the backplate with the 2 backplate screws and the collar.

Note: Do not pinch wires.

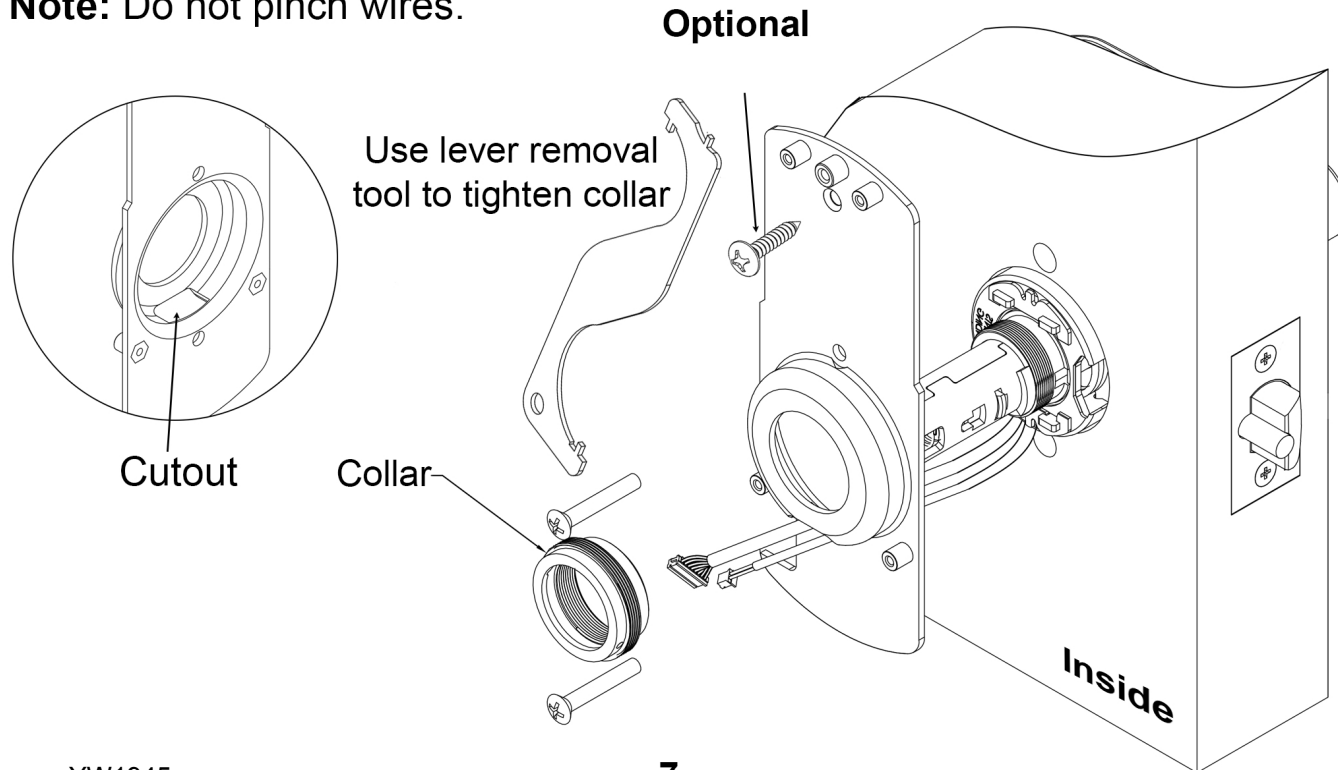

Step 4

Plug in the wire harnesses where indicated on the inside assembly.

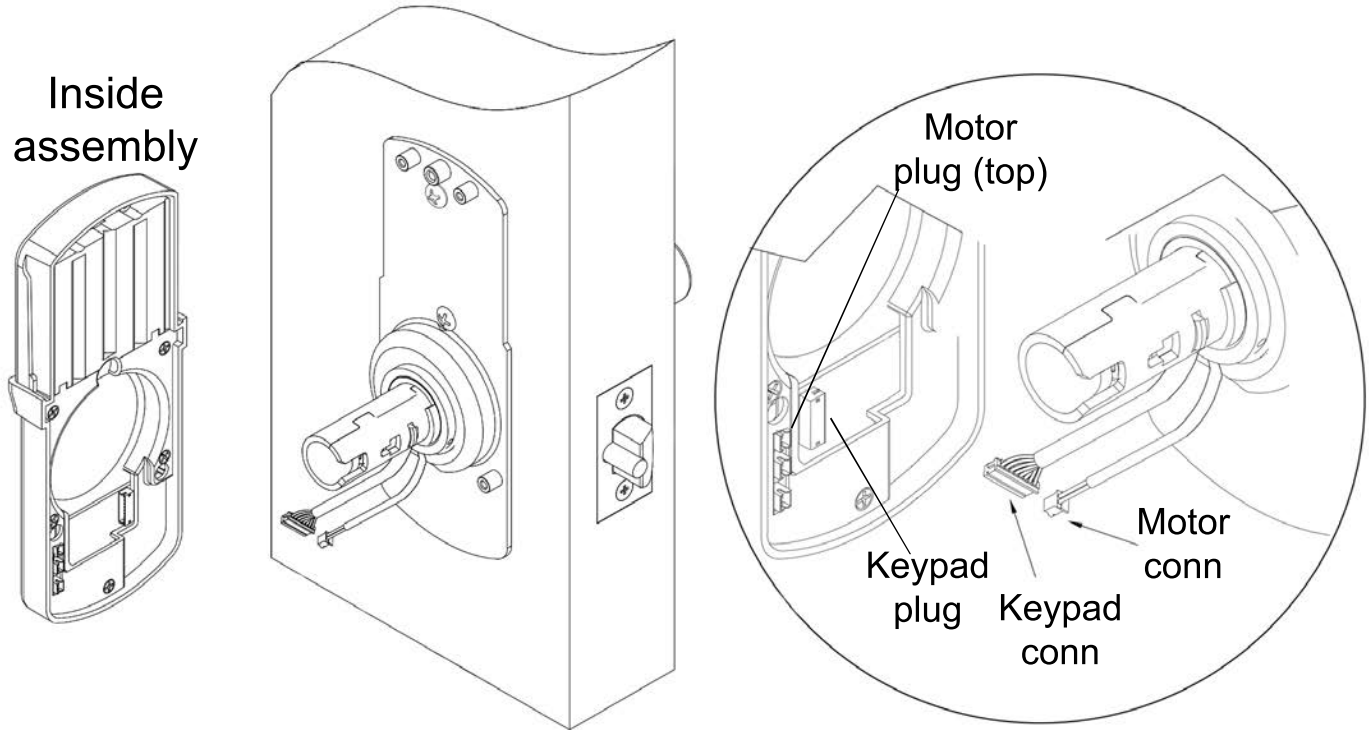

Step 5

Install inside assembly with 4 screws. Do not pinch wires. Install the 4 AA alkaline batteries provided. The keypad will light up green and the motor will run.

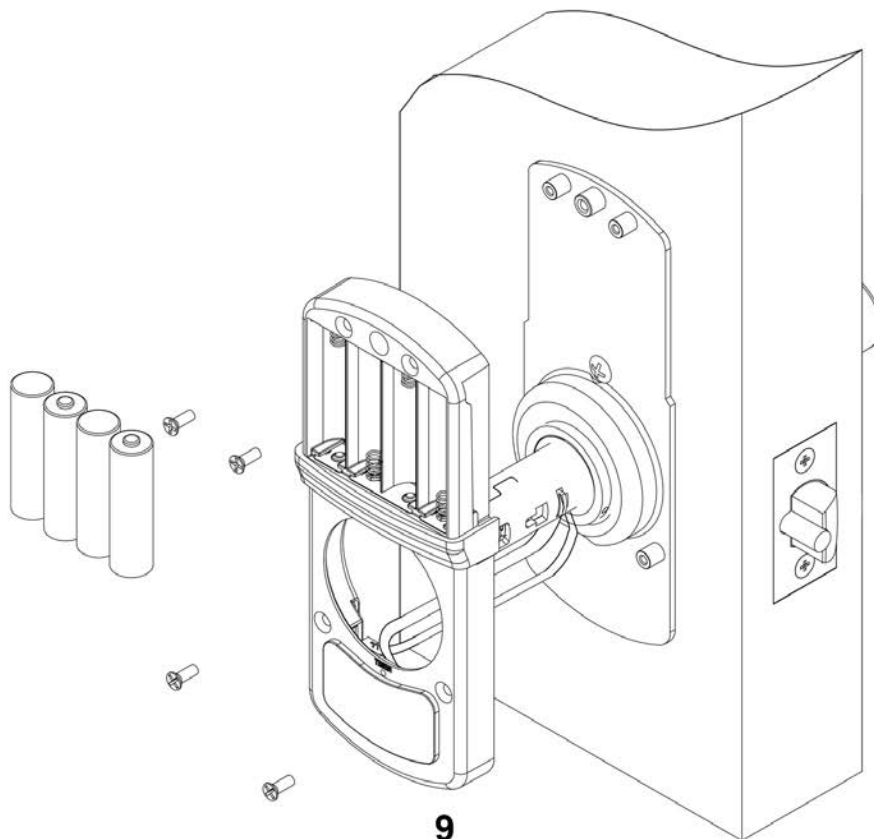

Step 6

Install inside lower cover first. Tighten the bearing ring to hold cover in place. Install the inside upper cover - slide down from top - secure with screw using the wrench provided.

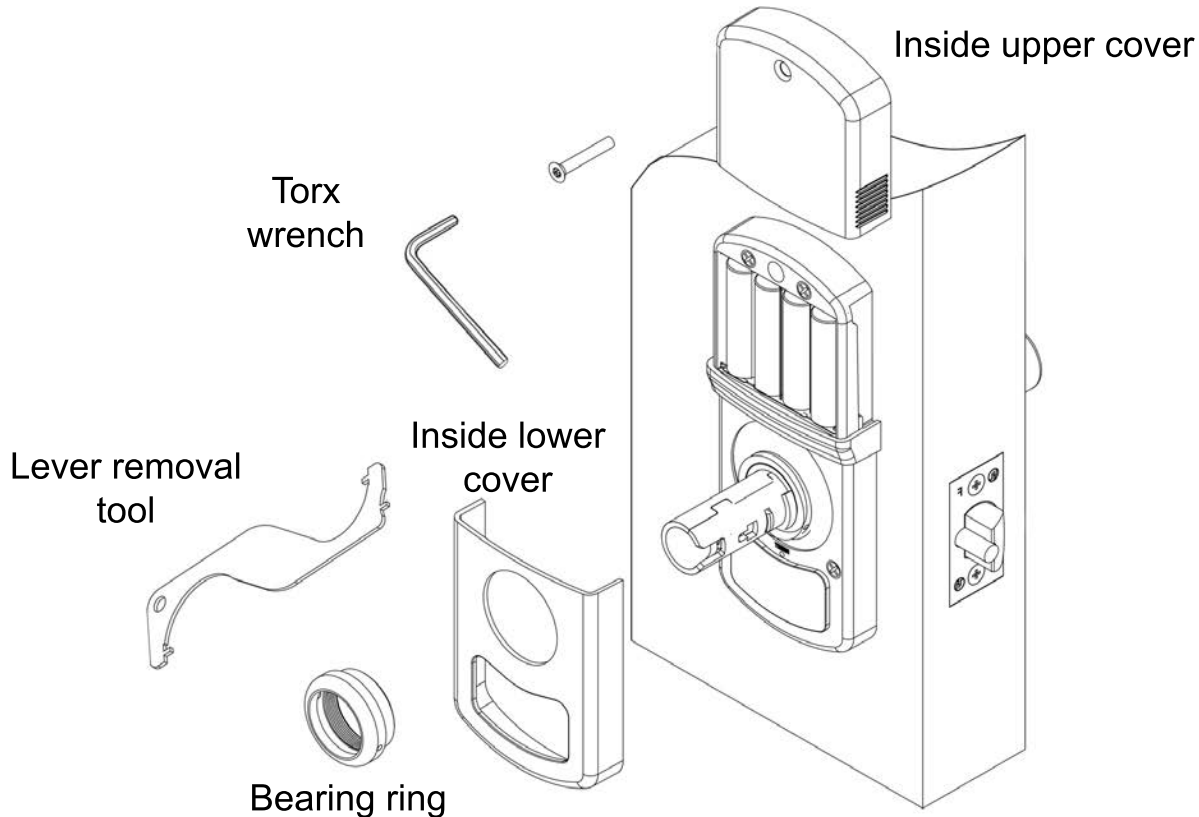

Step 7

Install the inside lever - ensure the lever is seated and is locked in place. Lever catch is on the side of lever and it should snap into place.

Note: Check lock for correct operation before closing the door. See programming guide for help.

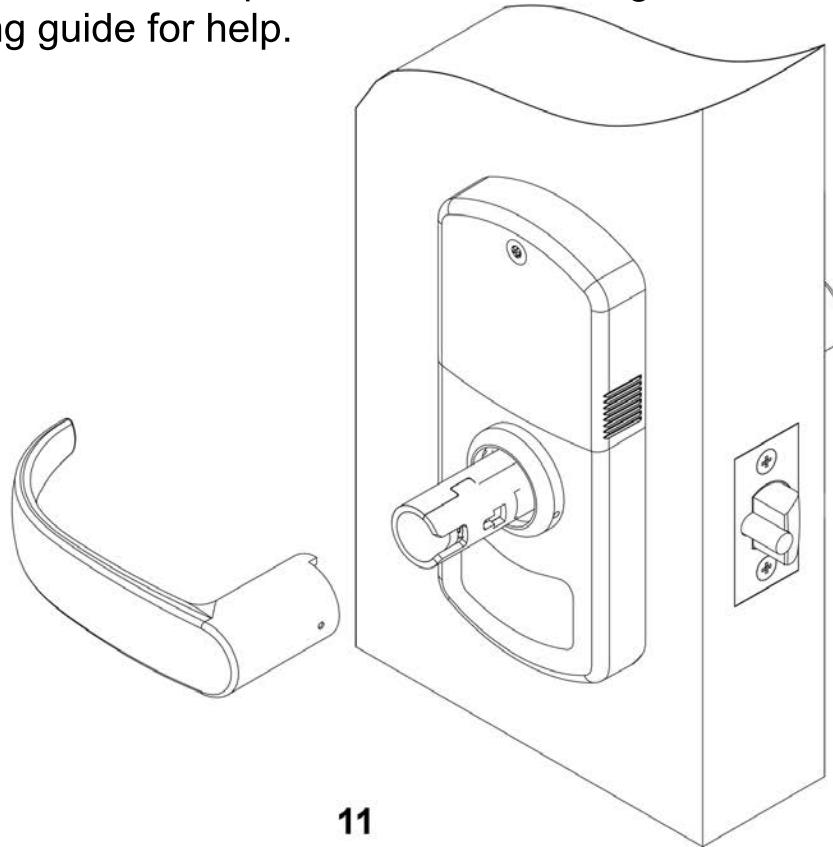

Addendum

1. Removing outer lever

Ensure the unit is locked, rotate key approximately 70°.

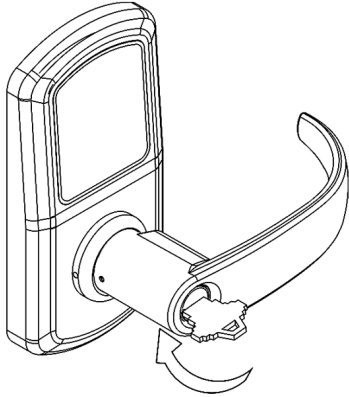

2. Insert lever removal tool into the lever catch hole and push back the lever catch.

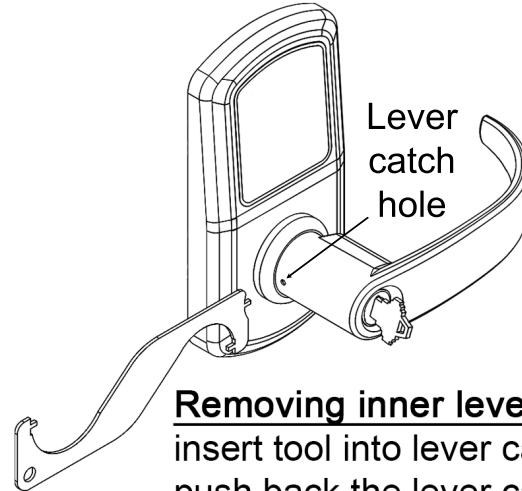

3. Remove lever.

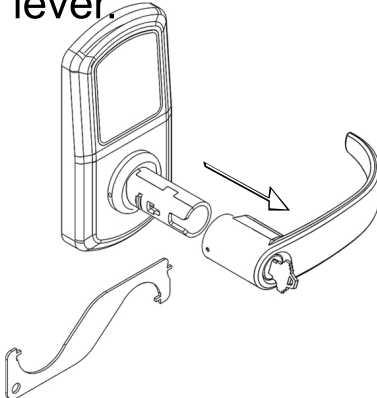

Removing inner lever

insert tool into lever catchholt & push back the lever catch, remove lever.

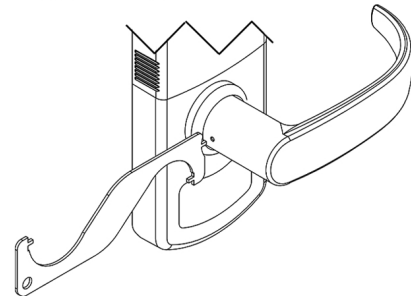

Exploded View

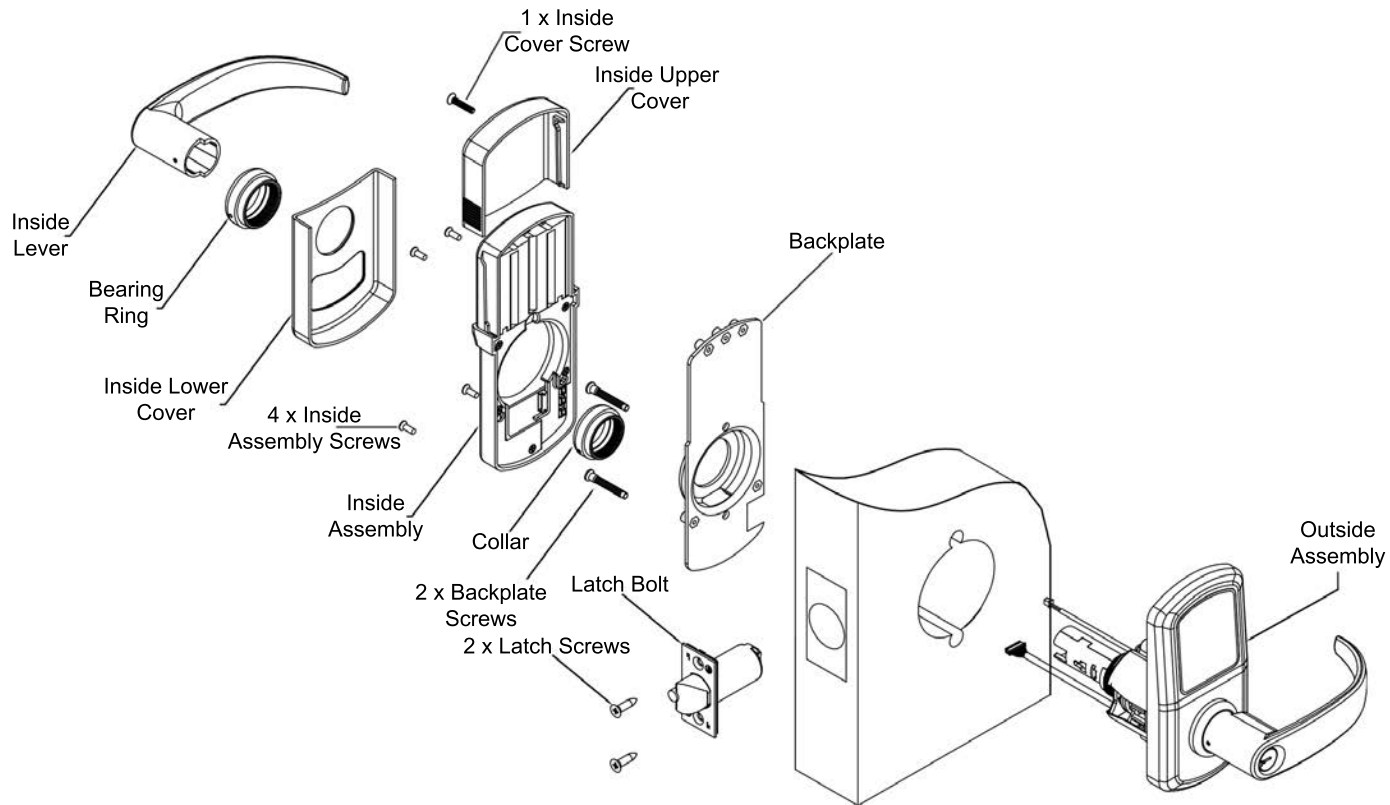

Problem	Cause	Solution
Keypad does not light up.	Batteries are dead.	Replace batteries by removing back cover.
	Keypad is locked out due to amount of incorrect codes	Wait 60 seconds and try again.
	Not fully plugged in wires or pinched wires.	Check wire connection.
Issues retracting latch.	Latch tail piece did not fully engage lock body retractor.	See Step 2.
Keypad lights up but motor does not respond.	Motor wire is not fully plugged in or has been pinched.	Undo the back cover and inside assembly. Inspect the motor wire.
	Motor wire was plugged into the wrong plug.	See Step 4.

VISIT WWW.TOWNSTEEL.COM FOR
17901 RAILROAD STREET CITY OF INDUSTRY, CA 91748
TOLL FREE: 877-858-0888
TEL: 626-965-8917