

TEMPLATE FOR FULL MORTISE SWING CLEAR CONTINUOUS GEARED ALUMINUM HINGE

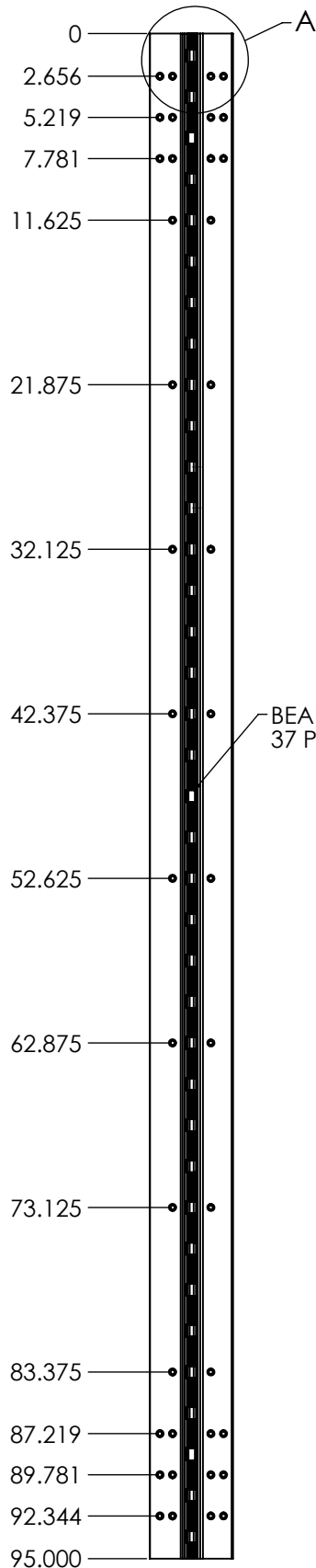

BEARINGS
37 PLACES

#12 FLAT HEAD SCREW
40 PLACES

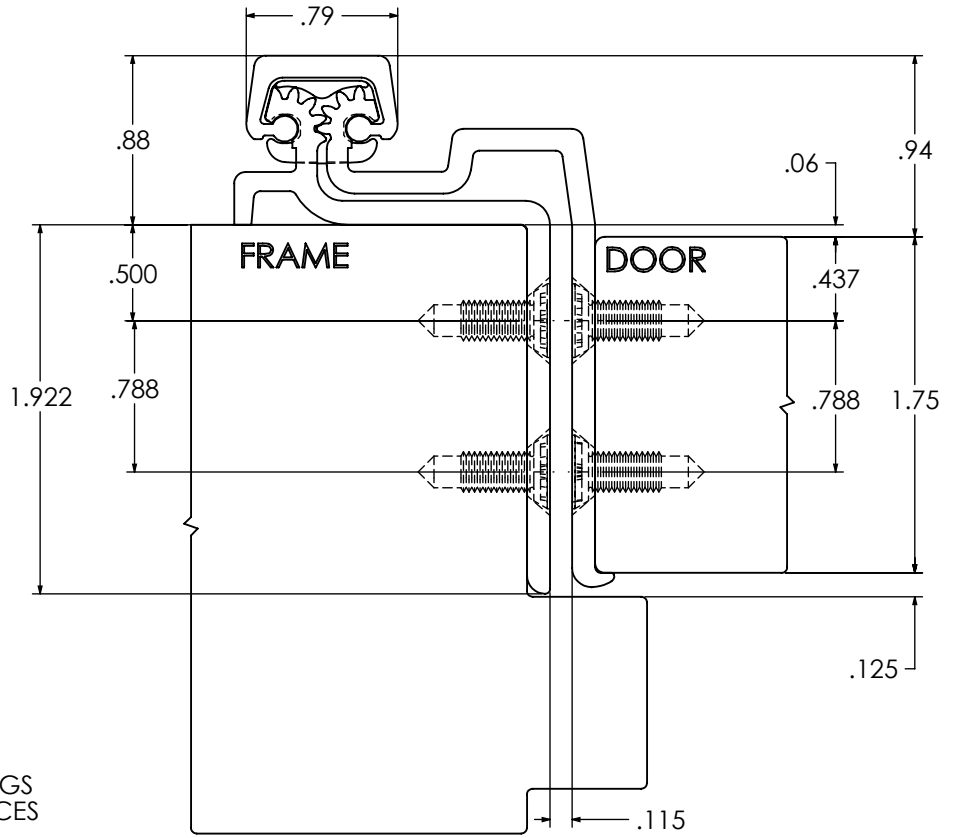

SCALE 1 : 1

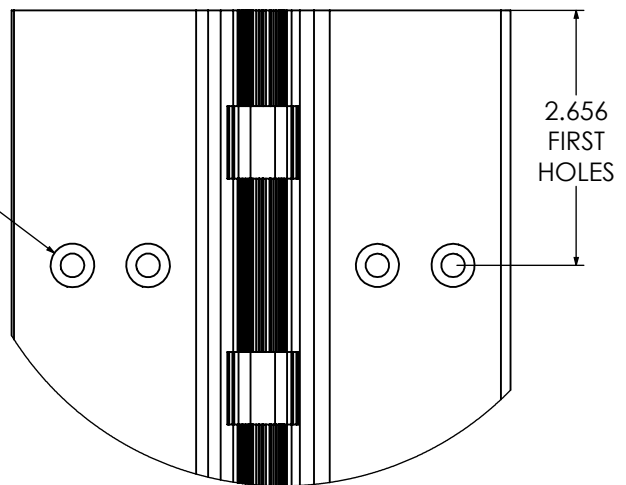

DETAIL A
SCALE 1 : 2

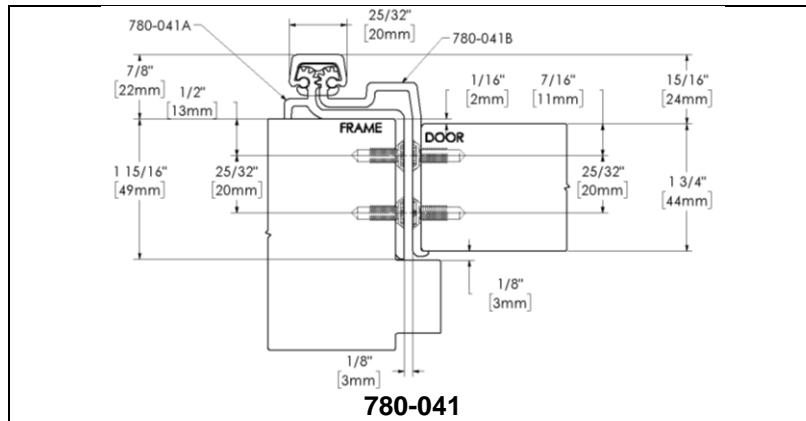

ROTON Models 780-041 is an Aluminum Continuous Geared Concealed Leaf Hinge which provides a 3/32" door inset. It can be used with any frame or frameless wall without hinge preps, and either with or without reinforcements depending on door weight. The frame rabbet must have a flat surface at least 1-15/16" wide and the frame face must have a flat surface of 1-17/32". Clearance required between the hinge edge of the door and the frame rabbet is 11/32" (8.7mm). "HD" models have additional bearings for heavy-duty application. Not recommended for use on doors that have a beveled edge on the hinge side.

Hinge Length

All ROTON Hinges are supplied approximately 1" shorter than the nominal door height to avoid threshold or carpet clearance problems. If the hinge must be trimmed shorter, first determine the correct hand of the door and orientation of the hinge. Then mark and trim from the *bottom* of the hinge only – do not cut from the top end.

NOM. DOOR HEIGHT	NOM. HINGE LENGTH	NUMBER OF FASTENERS (Door/Frame)
6'-8"	79" (2006mm)	15 / 15
7'-0"	83" (2108mm)	19 / 19
7'-2"	85" (2159mm)	19 / 19
8'-0"	95" (2413mm)	20 / 20
10'-0"	119" (3022mm)	23 / 23

Total Clearance Between Door And Frame Width

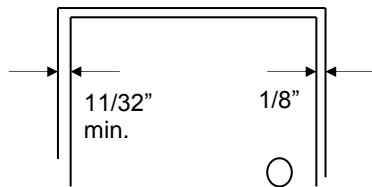

SINGLE DOOR - SQUARE EDGED

Hinge thickness	11/32" (8.7mm)
Allowance for frame irregularities	1/32" (0.8mm)
Latch side clearance (typical)	1/8" (3.2mm)
TOTAL*	1/2" (12.7mm)

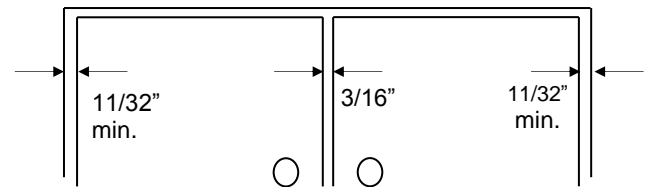

PAIR OF DOORS - SQUARE EDGED

First hinge thickness	11/32" (8.7mm)
First allowance for frame irregularities	1/32" (0.8mm)
Clearance between doors (typical)	3/16" (4.8mm)
Second hinge thickness	11/32" (8.7mm)
Second allowance for frame irregularities	1/32" (0.8mm)
TOTAL*	15/16" (23.8mm)

General Fitting Procedure

- For new construction with metal doors/frames: To accommodate the 11/32" (8.7mm) hinge clearance required for this ROTON model, order the door undersized or the frame header oversized. See the clearance information above to attain the proper size. Mortar guards, either Styrofoam or wood, are recommended for frames to prevent grout from interfering with the installation of the hinge fasteners.
- For new site-hung wood doors: If necessary, scribe and cut from the *latch edge* of the door to leave sufficient hinge stile thickness for proper fastening. A minimum clearance of 11/32" (8.7mm) is required between the hinge edge of the door and the frame rabbet. See the clearance information above to attain the proper finished width of the door.
- For remodeling with existing wood or laminate doors: If necessary, scribe and cut from the hinge edge of the door and plane smooth. A minimum clearance of 11/32" (8.7mm) is required between the hinge edge of the door and the frame rabbet. Do not bevel the hinge edge of the door. See the clearance information above to attain the proper finished width of the door.

Installation Procedure

Frame Preparation (See Fig. 1)

1. With the hinge open, place the hinge frame leaf against the frame rabbet making certain it is flush against the frame face and rabbet along its entire length. Position the top of the hinge 1/16" (1/8" maximum) below the header. **Note: A 1/16" shim is recommended due to initial settling of the bearings.**
2. Mark and center punch the screw hole locations. *Accurate location is important for proper installation.*
3. For metal frames 12 gage or less ($\leq .110"/2.8\text{mm}$), it is not necessary to pre-drill pilot holes if using the self-drilling screws provided. For metal frames greater than 12 gage ($> .110"/2.8\text{mm}$), drill and tap all mounting holes for #12-24 threads prior to installing the screws. For wood frames, pre-drill pilot holes using a #18 (.170"/4.3mm) bit for optional #12 wood screws.
4. *Do not attach the hinge to the frame at this time.*

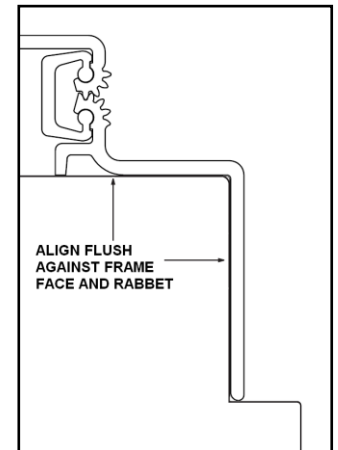

Fig. 1

Door Preparation

1. With the hinge open, place the hinge door leaf against the edge of the door making certain that the door alignment rib is flush against the door face along its entire length. (See Fig. 2)
2. Mark and center punch the screw hole locations. *Accurate location is important for proper installation.*
3. For hollow metal doors 12 gage or less ($\leq .110"/2.8\text{mm}$), it is not necessary to pre-drill pilot holes if using the self-drilling screws provided. For metal doors greater than 12 gage ($> .110"/2.8\text{mm}$), drill and tap all mounting holes for #12-24 threads prior to installing the screws. For wood doors, pre-drill pilot holes using a #18 (.170"/4.3mm) bit for optional #12 wood screws.
4. Attach the hinge to the door. For metal doors, use the #12 self-drilling screws provided (recommended driver speed 1,900-2,500 RPM). For wood doors, use optional #12 wood screws.

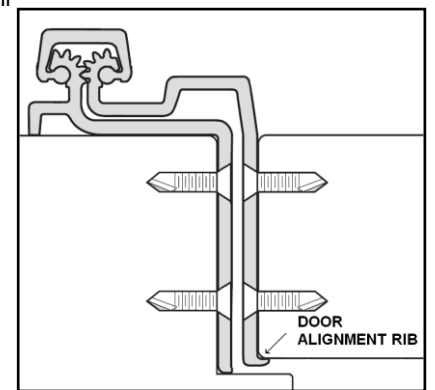

Fig. 2

Hanging the Door

1. Position the door (with hinge attached) at 90° to the frame. Attach the hinge to the frame rabbet. For metal frames, use the #12 self-drilling screws provided (recommended driver speed 1,900-2,500 RPM). For wood frames, use optional #12 wood screws.
2. Make a gentle trial swing. Carefully check the door for proper swing and clearance.

Adjusting the Door

1. If lateral adjustment of the door is required due to excessive or uneven door/frame clearance, adjust by shimming where needed:
 - a) For minor adjustments, an effective shimming material is 1-1/2" cloth duct tape. Apply the tape in stepped layers underneath the frame leaf where needed to build up to the desired thickness.
 - b) To shift the entire door, a thin continuous aluminum strip may be used underneath the frame leaf (available in 1/16" (1.6mm) and 1/8" (3.2mm) thicknesses from HAGER).
2. Retighten all screws. Carefully check the door for proper swing and clearance.

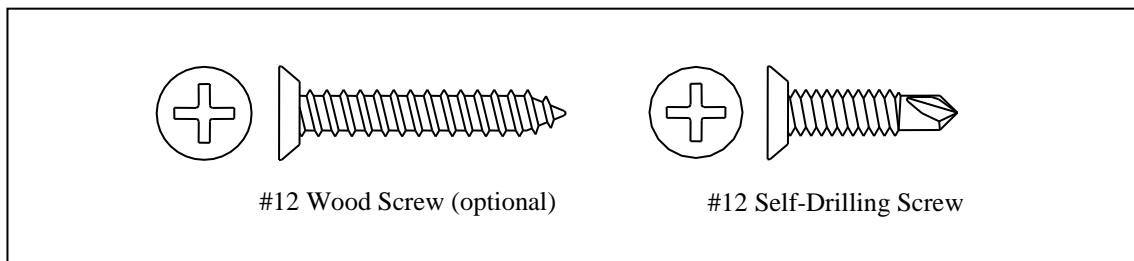

FOLDING INSTRUCTIONS

1. **DO NOT USE THIS DRAWING FOR PRINTING** - USE INSTRUCTION FILE.
2. SINGLE SHEET (20# WEIGHT), DOUBLE-SIDED PRINTING ON 8-1/2" X 11"
3. FOLD SHEET AS SHOWN IN DETAIL "A", FOLDING INSTRUCTIONS

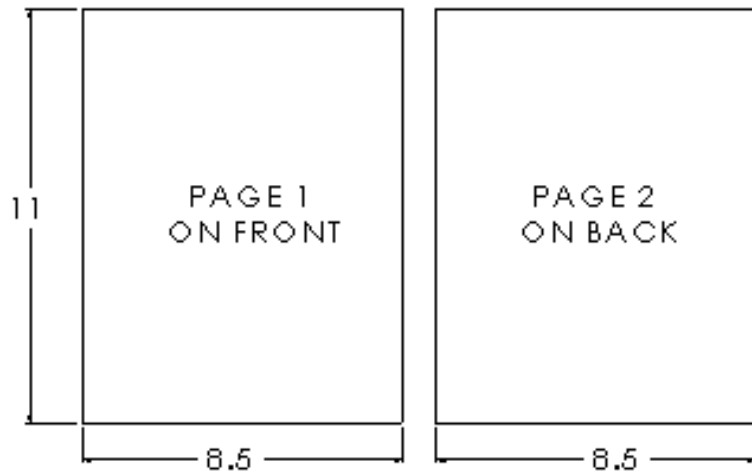

DETAIL "A" FOLDING INSTRUCTIONS

1. FOLD SHEET IN HALF ALONG WIDTH

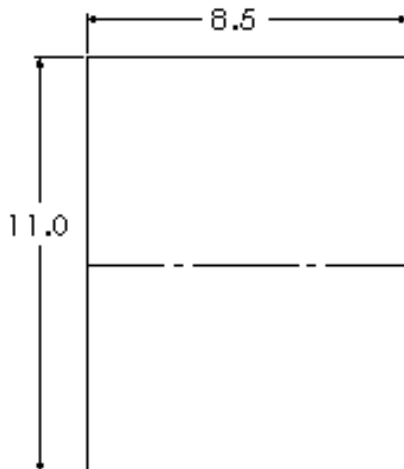

2. FOLD INTO THIRDS

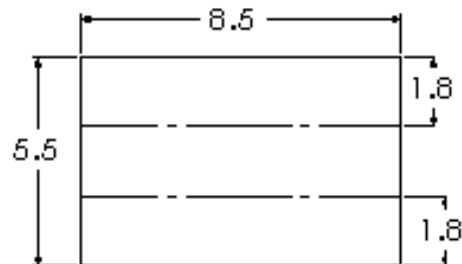

3. FOLDED SHEET WITH HAGER LOGO & REVISION DATE ON OUTSIDE

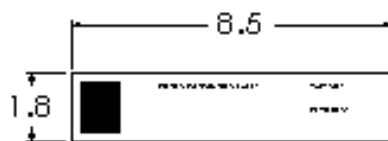

ROTON Hinge U.L. Fire-Rated Studs – 780-041

These instructions outline how to install the optional stainless steel studs (4) for ROTON Hinge model 780-041. All four studs must be used in order to comply with U.L. requirements for composite wood fire doors rated up to 90 minutes and metal fire doors rated up to 3 hours.

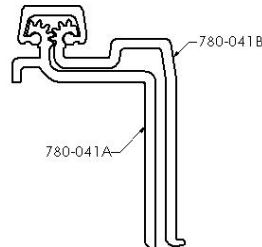

780-041

Materials Needed

- Stainless steel studs (4).
- Drill, 3/4" diameter bit, #16 (.177") bit, 12-24 thread tap.
- #10 spanner screwdriver.

Installation

1. Install the hinge in accordance with the standard installation instructions furnished with the hinge.
2. On the frame leaf, drill and tap 12-24 in the center of the four (4) pre-drilled 3/4" holes.

Vertical Location	9"	83"	85"	95"	119"
Hole #1	13-7/8"	15-7/8"	16-7/8"	16-3/4"	13-3/8"
Hole #2	10-1/4"	10-1/4"	10-1/4"	20-1/2"	30-3/4"
Hole #3	30-3/4"	30-3/4"	30-3/4"	20-1/2"	30-3/4"
Hole #4	10-1/4"	10-1/4"	10-1/4"	20-1/2"	30-3/4"

3. On the door leaf, drill a 3/4" diameter hole in each end of the slots on the leave. Trim out the material left between each horizontal pair of holes to create a 3/4" x 1-1/4" slot in the door leaf.
4. Insert a stud into each of the four #12-24 threaded holes on the frame and tighten securely using a #10 spanner screwdriver.
5. Close the door slowly to assure that the studs are properly aligned. Any minor interference can be corrected using a rat-tail file.

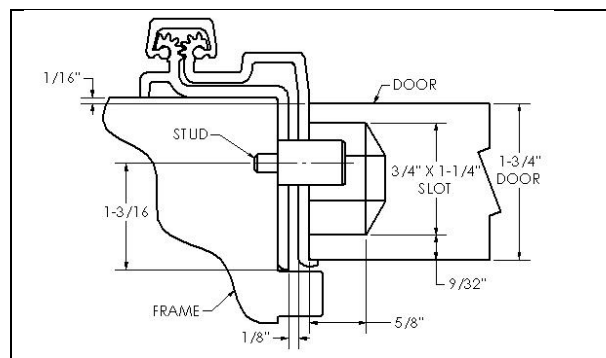
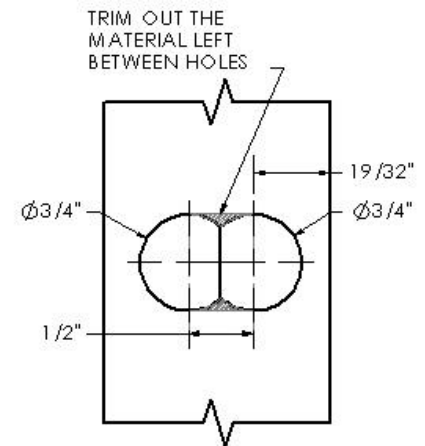

MODIFICATIONS & ADDITIONS

Special Cover Channels

Rounded back cover channels may be ordered. Availability for hinges with electrical modifications vary. Please consult the St. Louis sales office for confirmation.

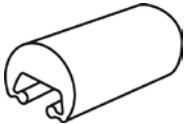

Round Back

Round Back Cover Channels

Clear Anodized

Sizes: 79", 83", 85", 95", 119"

Bronze Anodized

Sizes: 79", 83", 85", 95", 119"

Black Anodized

Sizes: 79", 83", 85", 95", 119"

Note:

Special cover channels available in clear, dark bronze and black finish.

Roton Cover Channel Compatibility		
Hinge Model	Flat FBCC	Round RBCC
750-134	•	•
750-138	•	•
780-041	•	•
780-045	•	•
780-046	•	•
780-053	•	•
780-054	•	•
780-057	•	•
780-110	•	•
780-111	•	•
780-112	•	•
780-113	•	•
780-124	•	•
780-155	•	•
780-157	•	
780-210	•	•
780-211	•	•
780-213	•	•
780-224	•	•
780-226	•	•
780-235	•	•
780-257	•	
780-300	•	

* Round back (RBCC) is not compatible with molded Hospital Tip option.

