



210XY Full surface - swing clear

- Patented center loaded, interlocking bearing design
- XY (lateral and vertical) adjustability while hanging the door
- Articulating cover design eliminates pinch point between center channel cover and door and frame leaf covers
- Non handed for custom cut lengths
- 1/32" door inset
- 48" Maximum door width
- Beveled or square edge doors
- For doors weighing up to 550 pounds
- For lead-lined application consult factory for engineering specials

Certifications

- Meets ANSI 156.26 for 150lbs and 300lbs
- UL10C certified

Standard lengths

- 83", 85", 95", 119"

Standard mounting hardware

- 12-24 x 3/4" Steel self drilling / self tapping hex head screw
- 12-24 x 3/4" Steel self drilling / self tapping phillips head screw

Finishes

- Clear Anodized (US28), Dark Bronze Anodized (313AN), Black Anodized (315AN)
- Custom anodizing and painting are available, consult factory.

Optional mounting hardware:

- SECHM. Security screws - hollow metal door and frame
- SECWDHM. Security screws - 1/2 wood, 1/2 hollow metal
- SECWDWD Security screws - wood door and frame
- TEKWD 1/2 self drill, self tap 1/2 wood
- WD. Wood door and frame

For single door applications:

For pairs of doors see chart and general information

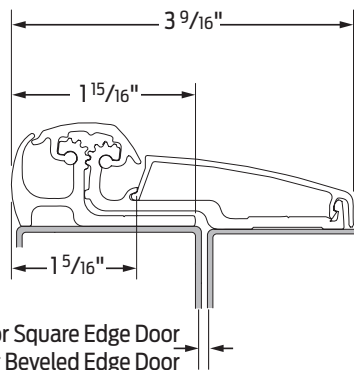

1/16" Clearance for Square Edge Door
3/32" Clearance for Beveled Edge Door