

K_FM

Copyright © 2013 Pemko Manufacturing Co. All rights reserved. Reproduction in whole or in part without the express written permission of Pemko Manufacturing Co. is prohibited.

K_FM_PDF Rev 2 - 06.07.13

Architectural Door Accessories

ASSA ABLOY

PemkoHinge®

The global leader in
door opening solutions

Applies to the following product:

K_FM

Continuous Geared Hinge

Standard Duty Full Mortise-Kawneer 6" Between Bearing Centers

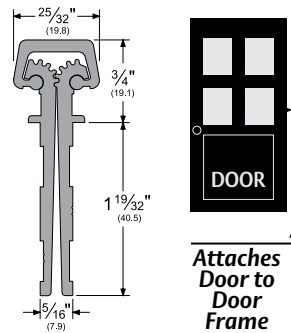

Attributes:

PemkoHinge® Attributes:

- With a continuous hinge, typical alignment problems, such as door sag and binding, are eliminated. Unlike conventional hinges, the continuous hinge distributes load stress uniformly along the full length of the door and frame.
- The gear design of the continuous hinge ensures identical operation of each leaf; therefore, very little effort is required to open heavy commercial doors.
- Continuous hinge installation screws are located along the full length of the hinge, thereby preventing warping of the door along the hinge jamb.
- The continuous hinge acts as reinforcement for both door and frame.
- A high degree of security can be achieved for exterior openings or restricted spaces by using a continuous hinge. With the geared construction and the full-length channel cap, the common gap between the door and frame is sealed, which provides security against prying.
- In addition, the closing of this gap protects against pinching fingers in doors in public areas, particularly those where children are present.
- Sightproof design of the continuous hinge provides privacy for lavatories, executive offices, or file rooms.
- PemkoHinge® products are GUARANTEED FOR THE LIFE OF THE OPENING against defects in material or workmanship with the exception of residential and aluminum hinges which carry a 10 year warranty.

Standard Duty Full Mortise-Short Leaf Flush:

- Designed mainly for new doors and frames.
- Applied to conceal both leaves.

Why PemkoHinge® ?

- Tested and certified with the best warranty in the industry.
- No restrictions on frame gauge and wall conditions.
- No restriction on cutting hinges in field.
- No special cutting instructions or voided warranties.
- No special door and frame preps up to and including 90 minute doors.

Product / Available Finishes:

KBLFM Black Anodized Aluminum
KDFM Dark Bronze Anodized Aluminum
KSNFM Satin Nickel Anodized Aluminum

KCFM Clear Anodized Aluminum
KPWFM Painted White Aluminum

Testing/Ratings:

Aluminum continuous hinge for use on swinging type fire doors of the hollow metal, tin-clad, sheet metal and steel covered composite type rated up to 3 hours, wood covered composite type rated up to and including 1-1/2 hours. Also wood core rated up to and including 20 minutes without hose stream. Meet criteria of UBC 7.2 for positive pressure.



LISTED
Door Hinges
76Y2

Architectural Door Accessories

ASSA ABLOY

PemkoHinge®

The global leader in
door opening solutions

Installation Instructions:

Full Mortise units are designed mainly for new doors and frames, and are applied so as to conceal both leaves. In retrofit applications, the door width must be reduced for proper clearance as shown in Figures A & B (below).

1. With the hinge leaves open, position the hinge against the frame rabbet. Be sure the leaf alignment flange is tight against the face of the frame. Allow 1/8" between the frame header and the top of the hinge leaf for door clearance. Mark and drill the top two holes per Drill Size Chart (below). (**Do not install**).
2. Position the door leaf of the hinge on the door. Be sure that the door leaf alignment flange is seated along the full length of the door edge, and the top edge of the door leaf is flush with the top edge of the door. Mark and drill all holes per Drill Size Chart. Thread tapping not required.
3. Screw the door leaf portion of the hinge to the door using the 12-24x7/16" thread forming screws. (Use wax or soap on screws to aid installation.)
4. Position the door at 90° to the frame. Install the top two screws in the frame leaf.
5. Close door and inspect for proper clearance and fit. Make adjustments as required due to improper frame installation if necessary to ensure proper operation of the complete assembly.
6. Mark and drill remaining frame leaf holes per Drill Size Chart, and install remaining screws.
7. FirePins are required on 3 hour (A-Label) assemblies. (See next page for instructions).

Shortening the Hinge:



If the PemkoHinge® must be shortened, cut the bottom only using a chop saw. This will allow metal chips to work out after the installation. Although the PemkoHinge® is not handed, the hinge becomes handed after cutting and the cut edge must be installed at the bottom of the opening.

Drill Size Chart:

MATERIAL	THICKNESS	DRILL SIZE
Aluminum	.090 - .140	13
Metal	20 gauge	17
Metal	16-18 gauge	15
Metal	12-14 gauge	13
Wood	N/A	5/32"

Figures:

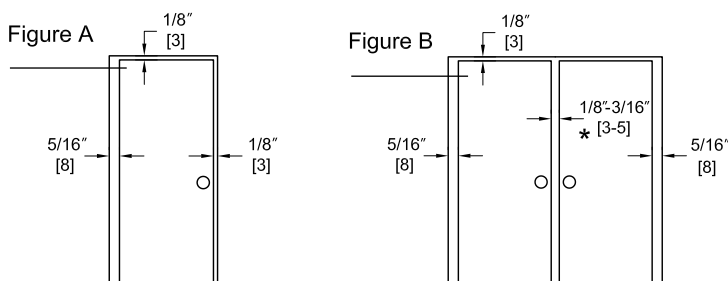

* Allow extra clearance as required per astragal manufacturer.

Testing/Ratings:

Aluminum continuous hinge for use on swinging type fire doors of the hollow metal, tin-clad, sheet metal and steel covered composite type rated up to 3 hours, wood covered composite type rated up to and including 1-1/2 hours. Also wood core rated up to and including 20 minutes without hose stream. Meet criteria of UBC 7.2 for positive pressure.



PemkoHinge®

The global leader in
door opening solutions

Fire Pins:

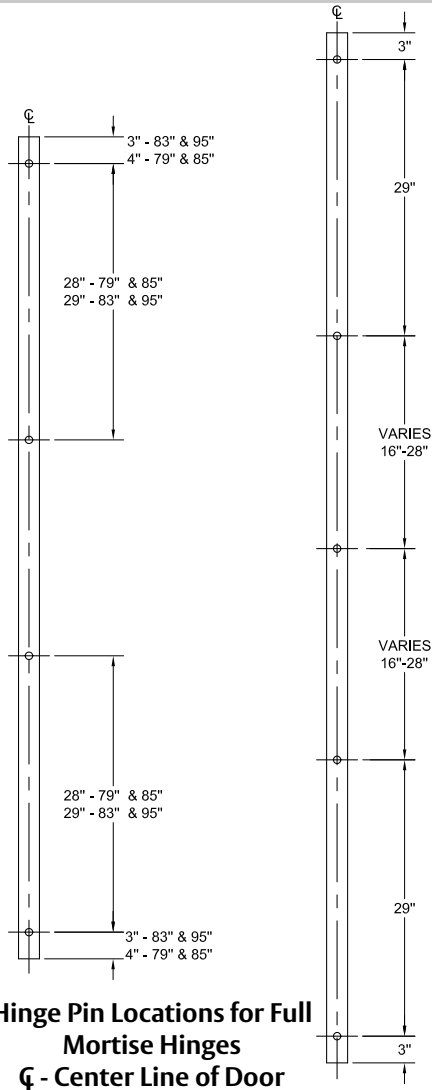

FIRE PINS ARE REQUIRED ON 3 HOUR RATED DOORS ONLY

PIN INSTALLATION:

Full Mortise (Edge Mounted) Hinge:

Install PemkoHinge® on door and frame prior to locating pins.

1. Drill and tap for 5/16-18 threads in frame as indicated on the template or the drilled frame leaf of the PemkoHinge®.
2. Insert Firepin in threaded hole.
3. Drill 3/4" hole 1/2" deep in edge of door where indicated on the template or the drilled door leaf of the PemkoHinge®.

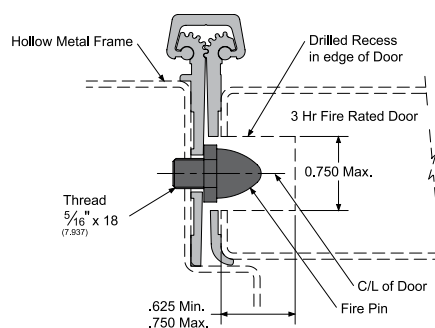

Testing/Ratings:

Aluminum continuous hinge for use on swinging type fire doors of the hollow metal, tin-clad, sheet metal and steel covered composite type rated up to 3 hours, wood covered composite type rated up to and including 1-1/2 hours. Also wood core rated up to and including 20 minutes without hose stream. Meet criteria of UBC 7.2 for positive pressure.



LISTED
Door Hinges
76Y2

Tools Required:

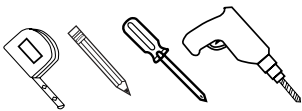

SECTION 08710
DOOR HARDWARE
(CONTINUOUS GEARED DOOR HINGES)

PART 1 GENERAL

1.01 SUMMARY

A. Section Includes: Continuous Geared Door Hinges.

Specifier Note: Revise paragraph below to suit project requirements. If a reader of this section could reasonably expect to find a product or component specified in this section, but it is actually specified elsewhere, then the related section number(s) should be listed in the paragraph below. Add section numbers and titles per CSI *MasterFormat* and specifier's practice. In the absence of related sections, delete paragraph below.

B. Related Sections:

1. Division 6 Section(s): Wood Frames.
2. Division 8 Section(s): Steel Doors, Wood Doors, Sound Control Doors, Aluminum Frame Storefront Doors.
3. Division 10 Section(s): Compartments and Cubicles, Partitions.
4. Division 13 Section(s): Special Facilities, Integrated Construction, Special Structures, Special Purpose Rooms.

Specifier Note: Article below may be omitted when specifying manufacturer's proprietary products and recommended installation. Retain References Article when specifying products and installation by an industry reference standard. If retained, list standard(s) referenced in this section. Indicate issuing authority name, acronym, standard designation and title. Establish policy for indicating edition date of standard referenced. Conditions of the Contract or Division 1 References Section may establish the edition date of standards. This article does not require compliance with standard. It is a listing of all references used in this section.

1.02 REFERENCES

A. ASTM International:

1. ASTM E2074 Standard Test Method for Fire Tests of Door Assemblies, Including Positive Pressure Testing of Side-Hinged and Pivoted Swinging Door Assemblies.

B. American National Standards Institute/Builders Hardware Manufacturers Association (ANSI/BHMA):

1. ANSI/BHMA A156.18 Materials and Finishes.
2. ANSI/BHMA A156.26 Standards for Continuous Hinges.

C. American National Standards Institute/Steel Door Institute (ANSI/SDI):

1. ANSI A250.8/SDI-100 Recommended Specifications for Standard Steel Doors and Frames.

D. American National Standards Institute/Window and Door Manufacturers Association (ANSI/WDMA):

1. ANSI/WDMA I.S.1-A Architectural Wood Flush Doors.

E. Federal Government:

1. U.S. Architectural & Transportation Barriers Compliance Board. Americans with Disabilities Act (ADA), Accessibility Guidelines for Buildings and Facilities (ADAAG), 1992.
2. Federal Standard FED-STD-795-1988 (Revised 1989) Uniform Federal Accessibility Standards.

F. Underwriters Laboratories, Inc. (UL):

1. UL 10B Fire Tests of Door Assemblies.

2. UL 10C Fire Tests of Door Assemblies.
3. UL 752 Bullet Resistant Equipment.

G. International Code Council (ICC):

1. UBC 7-2 Fire Test of Door Assemblies (Positive Pressure).
2. International Building Code (IBC) Code 2000 (Positive Pressure).
3. ICC/ANSI A117.1 Accessible and Usable Buildings and Facilities.

H. British Standards (BS):

1. BS 476 Fire Tests on Building Materials and Structures.

I. National Fire Protection Association (NFPA):

1. NFPA 1 Fire Prevention Code.

Specifier Note: Article below should be restricted to statements describing design or performance requirements and functional (not dimensional) tolerances of a complete system. Limit descriptions to composite and operational properties required to link components of a system together and to interface with other systems.

1.03 SYSTEM DESCRIPTION

A. Design Requirements: Provide continuous geared door hinges which have been manufactured, fabricated and installed to meet the following design criteria:

1. Continuous geared configuration, designed to distribute loads uniformly.
2. Identical operation in each leaf, designed to reduce door opening effort.
3. UL labeled for 3 hour fire classification.
4. Durability tested to ANSI/BHMA A156.26 Grade 1, 2, 3.

Specifier Note: Article below includes submittal of relevant data to be furnished by Contractor before, during or after construction. Coordinate this article with Architect's and Contractor's duties and responsibilities in Conditions of the Contract and Division 1 Submittal Procedures Section.

1.04 SUBMITTALS

A. General: Submit listed submittals in accordance with Conditions of the Contract and Division 1 Submittal Procedures Section.

B. Product Data: Submit manufacturer's product data and installation instructions.

C. Shop Drawings: Provide drawings indicating required component locations, installation interface with adjacent materials, anchorage, fastening and similar information.

D. Samples: Submit one each of manufacturer's standard selection samples.

E. Quality Assurance/Control Submittals: Submit the following:

1. Test Reports: Upon request, submit [Fire] [And] [Durability] test reports from recognized testing laboratory.
2. Certificates: Submit manufacturer's certificate that products meet or exceed specified requirements.

F. Closeout Submittals: Submit the following:

1. Warranty documents specified herein.

Specifier Note: Article below should include statements of prerequisites, standards, limitations and criteria that establish an overall level of quality for products and workmanship for this section. Coordinate article below with Division 1 Quality Assurance Section.

1.05 QUALITY ASSURANCE

A. Installer Qualifications: Utilize an installer having demonstrated experience on projects of similar size and complexity.

Specifier Note: Paragraph below should list obligations for compliance with specific code requirements particular to this section and authority having jurisdiction. General statements to comply with a particular code are typically addressed in Conditions of the Contract and Division 1 Regulatory Requirements Section. Repetitive statements should be avoided.

B. Regulatory Requirements and Approvals: [Specify applicable requirements of regulatory agencies].

1. [Code agency name].
 - a. [Report or approval number].

C. Certifications: [Specify requirement for certifications].

D. Field Samples: [Specify requirement for field samples].

E. Mock-Ups: [Specify requirements for mock-up].

1. Subject to acceptance by owner, mock-up may be retained as part of finish work.
2. If mock-up is not retained, remove and properly dispose of mock-up.

Specifier Note: Retain paragraph below if preinstallation meeting is required.

F. Preinstallation Meetings: [Specify requirements for meeting].

Specifier Note: Article below should include specific protection and environmental conditions required during storage. Coordinate article below with Division 1 Product Requirements Section.

1.06 DELIVERY, STORAGE & HANDLING

A. General: Comply with Division 1 Product Requirement Section.

B. Delivery: Deliver materials in manufacturer's original, unopened, undamaged containers with identification labels intact.

C. Storage and Protection: Store materials protected from exposure to harmful environmental conditions and at temperature and humidity conditions recommended by the manufacturer.

Specifier Note: Coordinate article below with Conditions of the Contract and with Division 1 Closeout Submittals (Warranty) Section. Use this article to require special or extended warranty or bond covering the work of this section.

1.07 WARRANTY

A. Project Warranty: Refer to Conditions of the Contract for project warranty provisions.

B. Manufacturer's Warranty: Submit, for Owner's acceptance, manufacturer's standard warranty document executed by authorized company official. Manufacturer's warranty is in addition to, and not a limitation of, other rights Owner may have under contract documents.

Specifier Note: Coordinate subparagraph below with manufacturer's warranty requirements.

1. Warranty Period: Warranty for life of door opening, beginning with date of substantial completion.

PART 2 PRODUCTS

Specifier Note: Retain article below for proprietary method specification. Add product attributes, performance characteristics, material standards and descriptions as applicable. Use of such phrases as "or equal" or "or approved equal" or similar phrases may cause ambiguity in specifications. Such phrases require verification (procedural, legal and regulatory) and assignment of responsibility for determining "or equal" products.

2.01 CONTINUOUS GEARED DOOR HINGES

Specifier Note: Paragraph below is an addition to CSI *SectionFormat* and a supplement to MANU-SPEC. Retain, edit or delete paragraph below to suit project requirements and specifier practice.

A. Manufacturer: Pemko Manufacturing Company.

1. Contact: PO Box 3780, 4226 Transport Street, Ventura, CA 93003; Telephone: (800) 283-9988, (805) 642-2600; Fax: (805) 642-4109; E-mail: pemkosales@pemko.com; website: www.pemko.com.

B. Proprietary Products/Systems: Continuous Geared Door Hinges, including the following:

1. Continuous Geared PemkoHinges:
 - a. Material: Extruded tempered aluminum.
 - b. Material Standard: 6063-T6 alloy.

- c. Configuration: Three interlocking extrusions in pinless assembly, installed to full height of door frame.
- d. Finish (ANSI/BHMA A156.18): [Clear anodized] [Dark anodized] [Gold anodized].
- e. Type: [Full mortise] [Full surface] [Half surface] [Full mortise residential: 1 3/4 inches (45 mm)] [Full mortise residential: 1 3/8 inches (35 mm)] [Special full mortise] [Wide throw full mortise].
- f. Length: [79 inches (2007 mm)] [83 inches (2108 mm)] [85 inches (2159 mm)] [95 inches (2413 mm)] [120 inches (3048 mm)].
- g. Hinge Options: [Safety] [Short leaf flush] [Short leaf inset] [Standard] [Safety short leaf inset] [Center pivot].
- h. Electrical Modifications: [Specify electrical modifications.].
- i. Strength: [Standard Duty: 14 bearings each leaf for 83 inch (2108 mm) hinge, minimum door weight 280 lb (127 kg)] [Heavy Duty: 27 bearings each leaf for 83 inch (2108 mm) hinge, minimum door weight 540 lb (245 kg)].
- j. Mortise Fasteners: TEK, #12 × 3/4 inch, FHUC, Phillips head screws.
- k. Fire Label Certification: Comply with ASTM E2074, NFPA 1, UBC 7-2, BS 476, UL 10B, UL 10C, [90 minutes for wood doors] [3 hours for hollow metal doors].
- l. Testing Standard: Tested according to ANSI/BHMA A156.26.

Specifier Note: Edit Article below to suit project requirements. If substitutions are permitted, edit text below. Add text to refer to Division 1 Project Requirements (Product Substitutions Procedures) Section.

2.02 PRODUCT SUBSTITUTIONS

A. Substitutions: No substitutions permitted.

PART 3 EXECUTION

Specifier Note: Article below is an addition to the CSI *SectionFormat* and a supplement to MANU-SPEC. Revise article below to suit project requirements and specifier's practice.

3.01 MANUFACTURER'S INSTRUCTIONS

A. Comply with the instructions and recommendations of the continuous geared door hinge manufacturer.

Specifier Note: Specify actions to physically determine that conditions are acceptable to receive primary products of the section.

3.02 EXAMINATION

A. Site Verification of Conditions:

1. Verify that site conditions are acceptable for installation of continuous geared door hinges.
 - a. Examine doors and frames for compliance with requirements for installation tolerances, labeled fire door assembly construction, wall and floor construction and other conditions affecting performance.
 - b. Ensure frame is square and plumb before installation.
 - c. Examine roughing-in for electrical wiring connections.
2. Do not proceed with installation of continuous geared door hinges until unacceptable conditions are corrected.

Specifier Note: Specify actions required to physically prepare the surface, area or site or to incorporate the primary products of the section.

3.03 PREPARATION

A. Wood Door Preparation: Comply with ANSI/WDMA I.S.1-A.

B. Steel Door and Frame Preparation: Drill doors and frames for hardware per manufacturer's installation instructions. Comply with ANSI A250.8/SDI-100.

Specifier Note: Coordinate article below with manufacturer's recommended installation requirements.

3.04 INSTALLATION

A. Mounting Location: Comply with the following requirements, unless otherwise indicated:

1. Steel Doors and Frames:
 - a. Comply with ANSI A250.8/SDI-100.
 - b. Ensure frames are properly sized, plumb and square.
 - c. [Specify standard or specific requirements.].
2. Wood Doors:
 - a. Comply with ANSI/WDMA I.S.1-A.
 - b. Ensure doors are properly sized, plumb and square.
 - c. [Specify standard or specific requirements.].

B. Adjust and reinforce attachment substrates as necessary for proper installation and operation.

C. Space fasteners and anchors according to manufacturer's product instructions.

Specifier Note: Specify the final actions required to prepare installed equipment or other completed work to properly function or perform.

3.05 ADJUSTING

A. Perform adjustments required to ensure that continuous geared door hinges function in compliance with manufacturer's performance criteria prior to acceptance by Owner.

1. Adjust door control devices to compensate for final operation of HVAC system and to comply with accessibility requirements.

Specifier Note: Specify the final actions required to clean installed equipment or other completed work to properly function or perform. Coordinate article below with Division 1 Execution Requirements (Cleaning) Section.

3.06 CLEANING

A. Remove any protective films and clean components as necessary following manufacturer's recommended procedures.

Specifier Note: Specify provisions for protecting work after installation but prior to acceptance by Owner. Coordinate article below with Division 1 Execution Requirements Section.

3.07 PROTECTION

A. Protect installed work from damage due to subsequent construction activity on the site.

END OF SECTION