

MATERIAL: Extruded 6063 T6 aluminum alloy with self-lubricating polyester thrust bearings.

LENGTHS: 83", 85", 95" and 120" lengths standard for nominal door heights. Custom lengths are available.

LOAD/FREQUENCY RATINGS: For 1-3/8" – 1-3/4" doors standard; long barrel nuts available for 2" – 2-1/4" doors. 48" max. door width in 16 gauge hollow metal (min.) or 1/8" aluminum (min.).

Heavy Duty – Tested per BHMA standards. Up to 200 lb. doors (high-frequency) and up to 400 lb. doors (medium-frequency) without frame or door reinforcement; up to 600 lb. doors (low-frequency) with the use of Rivnuts in the frame.

FINISHES: All SL54 hinges are stocked in Clear and Dark Bronze anodized aluminum. Custom anodized or painted finishes are available. Product painted or anodized in the field voids the SELECT hinge warranty.

CLOSERS: Conventional overhead surface, concealed sliding arm overhead or floor closers may be used with SELECT hinges. Pivot-type floor closers (with a fixed, conflicting center pivot) must be replaced.

ORDER: Specify length, finish and heavy duty (HD). Also, specify door and frame screw applications. 12-24 x 3/4" self-drilling, thread-forming 410SS Phillips undercut flathead screws, 1/4-20 through-bolts and 1/4-20 shoulder screws (for doors up to 1-3/4" thick) are provided as a standard pack unless otherwise specified. Wood and thread-forming screws also available. Security screws optional at extra cost.

AVAILABLE ELECTRIC PREPS: EPT.

BHMA CERTIFICATION: SL54HD geared continuous hinges conform to BHMA Standard ANSI/BHMA **BHMA CERTIFIED** A156.26-2006 Grade 1.

SL54 HINGE SCREW COUNT		
HINGE LENGTH & DUTY RATING	DOOR SCREWS	FRAME SCREWS
83" HD	10	19
85" HD	10	19
95" HD	11	21
120" HD	14	23

SELECT ADVANTAGES



PAIR-MATCHED™ HINGE LEAVES

Manufactured together, machined together and anodized together, making SELECT hinges fit your doors better and last longer. An exclusive SELECT benefit.



LIFETIME LUBRICATION

Eliminates the need for periodic maintenance. Quiet performance. Fights gear cap wear. An exclusive SELECT benefit.



ANODIZED AFTER MACHINING

Delivers superior wear, durability and life. Inhibits corrosion. Few hinge makers follow SELECT's lead in using this superior manufacturing process.



MEETS LEED REQUIREMENTS

Made from recycled aluminum. Reduces environmental impact and qualifies for LEED points. An exclusive SELECT benefit.

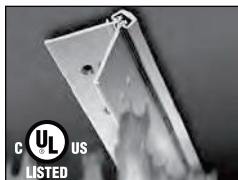

PATENTED 3-HR. FIRE RATING

Most SELECT hinges are fire rated for 90 minutes. 3-Hr. fire rating, optional at extra cost, approved for positive/negative pressure. No fire pins or studs required. Patented design innovation. An exclusive SELECT benefit.

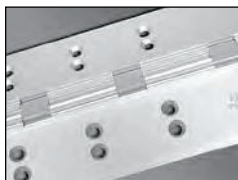

CONSISTENT TEMPLATING

Hole pattern is identical on both Standard and Heavy Duty models, so SELECT hinges line up precisely for easier and faster installation. An exclusive SELECT benefit.



COATED FASTENERS

Provide additional corrosion protection with either self-drilling, thread-forming (SDTF) or thread-forming (TF) screws. An exclusive SELECT benefit.



CUSTOM COLORS

Match any paint color on the gear cap or the entire hinge and fasteners, including our always-in-stock Bone White gear caps. Anodized colors also available.

SELECT HINGE PERFORMANCE

- A SELECT geared continuous hinge has been tested in accordance with ANSI 250.4-1994 test procedure and acceptance criteria for physical endurance for steel doors and hardware and has surpassed 25,000,000 cycles during testing by an independent laboratory. On a door cycling 400,000 times per year, a SELECT hinge will be performing for over 62 years.
- SELECT geared continuous hinges are built to handle abuse from high-traffic applications. They are applied to the surface on the edge of the frame and door. No machining or reinforcement is required.
- The revolutionary SELECT geared continuous hinge puts an end to costly and irritating hinge failure problems, the most common cause of entrance failure.
- On conventional hinges, opening and “kick-back” energy concentrate on a few inches of fastened reinforcing plate — with the top hinge handling 100% of the force. Pinless SELECT hinges bond the door and frame into an integrated, sag-free unit. “Kick-back” energy dissipates along the entire length of the door and frame. (Compare this to a conventional hinge’s 4-1/2" to 5" at the top of the door and frame).
- SELECT geared continuous hinges eliminate the gap between the door and frame, providing a weatherproof, rust-proof, tamper-proof barrier. When the door is closed, there are no accessible screws, bolts or pins.
- SELECT SL54 geared continuous hinges are listed and tested by Underwriters Laboratories to meet the Positive and Negative pressure requirements of UL10B and UL10C, and are in accordance with UBC 7.2 (1997). SELECT SL54 geared continuous hinges are for use on swinging single fire doors (max. door opening of 4'x10') or pairs of fire doors (max. door opening of 8'x10'), including double egress, installed in masonry or drywall. SELECT SL54 geared continuous hinges are rated for up to 1-1/2 hours for wood composite and wood core type fire doors. A special patented process can be added to increase the fire rating to 3 hours (NO FIRE PINS OR STUDS REQUIRED) for hollow metal or steel covered composite type doors.

Half Surface Geared Continuous Hinges

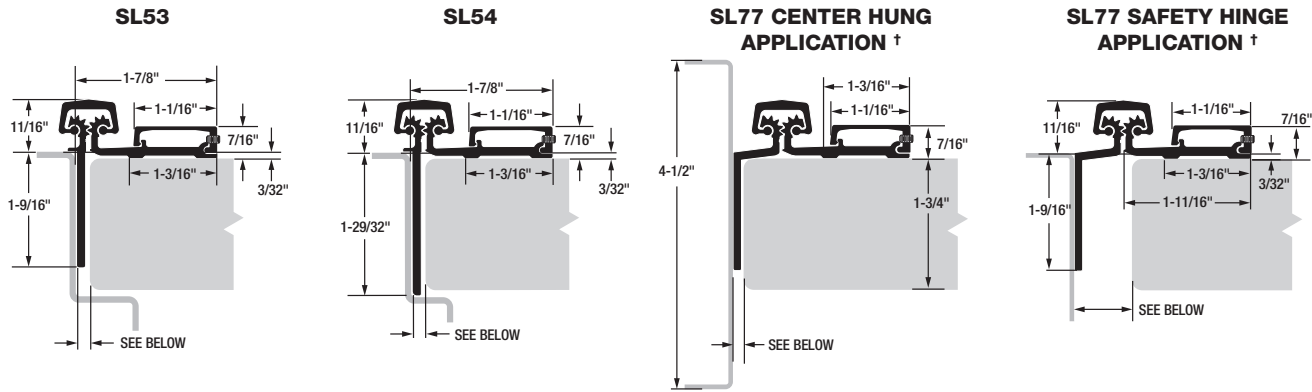

† Please note the SL77 is not fire-rated.

Door Clearances

For Square and Beveled-Edge Doors

IMPORTANT: All uncut SL53, SL54 and SL77 hinges are non-handed and templated. They become handed after cutting. If door inset is required, install a continuous piece of shim under the door leaf.

* NOTE: Refer to NFPA 80 manual for clearance requirements on fire-rated entrances.

Important Warranty Information:

The following actions will void any warranty, expressed or implied:

- Failure to install the hinge according to manufacturer's specifications and requirements. (For more information, visit selecthingerequirements.com.)
- Use of fasteners other than those supplied with the hinge.
- Unauthorized field modifications, including alteration or removal of the factory-applied lubricant, altering the original finish or painting the hinge.

Single Door

Hinge side clearance

SL53 & SL54	* 3/16"
SL77 Center Hung	* 5/32"
SL77 Safety Hinge	* 13/16"

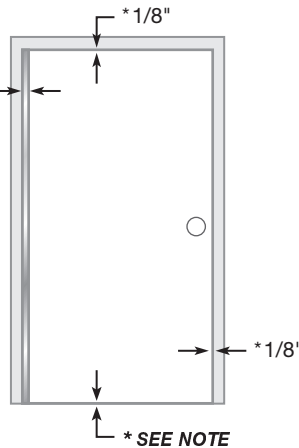

Double Doors (Pair)

Hinge side clearance

SL53 & SL54	* 3/16"
SL77 Center Hung	* 5/32"
SL77 Safety Hinge	* 13/16"

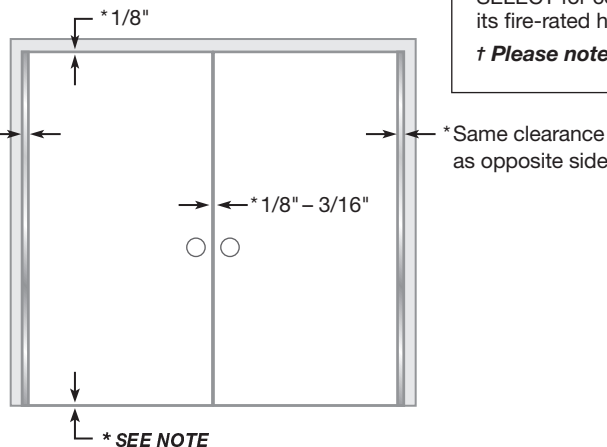

Reinforcing & Rivnuts®

No hinge reinforcement is necessary except on extremely high-frequency, extremely heavy or extra-wide doors. Rivnuts are recommended for use in the frame when the door exceeds 450 lb. (max. 600 lb.)

NOTE: Only SELECT steel Rivnuts® are to be used with fire-rated SELECT hinges.

Grouted/Slushed-in Frames

For ease of installation, it is recommended some sort of mudguard be installed behind the frame. Do not use self-drilling, thread-forming (SDTF) screws to drill into grouted frames. If mudguards have not been used, carefully drill pilot holes through frame and remove grout for screw clearance. Do not oversize holes in frame.

Fire-Rated Hinges†

All stock SELECT hinges are 90-minute UL-rated, without pins. Please contact SELECT for complete information about its fire-rated hinges.



† Please note the SL77 is not fire-rated.

Tools Needed

- Metal-cutting saw
- Tape measure
- #13 or 3/16" drill bit & 3/8" drill bit
- 5/32" drill bit (wood frames only)
- #3 Phillips drive
- 5/64" Allen wrench
- Hammer
- Shims

Parts Supplied

- #12-24 self-drilling, thread-forming (SDTF) 410 SS Phillips undercut flathead screws
- #12-24 self-drilling, thread-forming (SDTF) 410 SS Phillips undercut panhead screws
- 1/4-20 barrel nuts (through bolts)
- 1/4-20 shoulder screws
- 7/32" center punch
- 3/8" center punch
- Set screws

Optional Parts

- #12 410 SS Phillips undercut flathead wood screws
- #12-24 thread-forming (TF) 410 SS Phillips undercut flathead screws
- Long barrel nuts for doors 2"–2-1/4" thick
- Protective gloves are recommended

How to Cut the Hinge to Fit

- Keep hinge in "door closed" position (Fig. 1).
- Determine whether this will be a right-hand or left-hand installation.

IMPORTANT: Cut only one end of hinge. Cut end will be installed at the bottom. Keep original templated six-hole pattern at top end of hinge.

- Using a metal-cutting saw, begin the cut through the gear cap first.

NOTE: DO NOT cut through a set screw bearing.

- Loosen set screw from side of door leaf cover with 5/64" Allen wrench (Fig. 1).
- Remove door leaf cover by sliding it off uncut end of hinge.
- Reinstall any set screw bearing that may have been cut off.

A. Attach Hinge to Frame

NOTE: Remove door leaf cover if not already removed. See step D above.

- Shim hinge to 1/8" below the header to allow for door clearance.
- Hold hinge in "door open" position (Fig. 2) making sure frame leaf alignment flange is tight against frame rabbet.
- Mark (or centerpunch) two holes at top and two holes at bottom of frame leaf.

NOTE: TF screws and wood screws require pilot holes at marked locations. SDTF screws do not require pilot holes.

Fig. 1 Door Closed Position

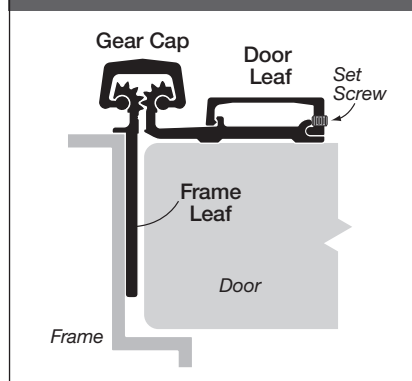

Fig. 2 Door Open 90°

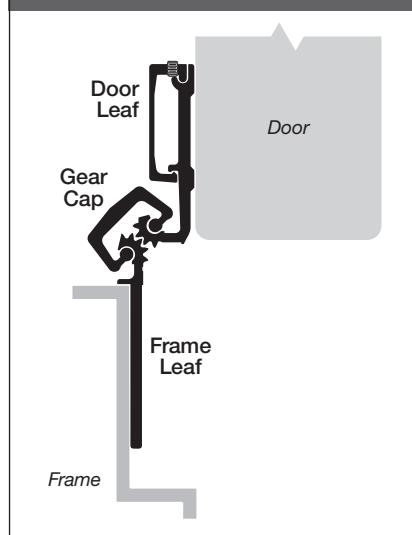
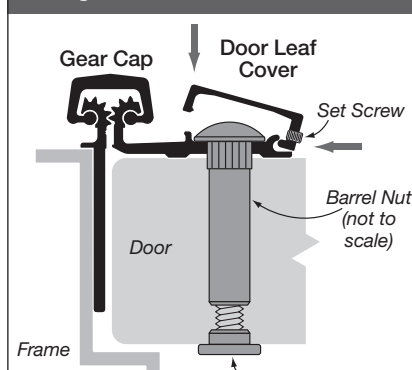

Fig. 2 Leaf Cover Installation



SECURED SIDE, OUTSWING

NOTE: For inswing applications, reverse position of barrel nut and shoulder screw so that the shoulder screw is on the secured side of the door.

- If using SDTF screws, go to Step 5. If using TF or wood screws, drill holes at marked locations.
 - Metal frame: Use #13 (.185") bit or 3/16" (.188") bit
 - Wood frame: Use a 5/32" (.156") bit
- Fasten frame leaf to door frame using two screws at the top and two screws at the bottom.
 - Metal frame: Use #12-24 TF flathead screws provided, or use #12-24 SDTF flathead screws (provided on request)
 - Wood frame: Use #12 flathead wood screws (provided on request)

B. Prepare Door

- Shim door into opening to provide required hinge clearances.

IMPORTANT: Top end of the hinge must be flush with the top of the door.

IMPORTANT: A 13/16" gap between door edge and a frame without a stop is necessary for the SL77 safety feature to be effective. See illustration on other side.

- Mark locations for the four SDTF panhead screws on the door using 7/32" center punch.
- With #3 Phillips drive, temporarily attach door leaf to door through the four locator holes with SDTF panhead screws provided.
- Remove shims and check door clearances, alignment and operation.

NOTE: Door may sag slightly when shims are removed. Note the amount of adjustment needed to bring door back into alignment.

DO NOT PROCEED UNTIL DOOR OPERATES PROPERLY.

- Mark locations for barrel nuts on the door using 3/8" center punch.
- Remove door and lay it flat. Use 3/8" drill bit to drill holes at marked locations.

NOTE: Be sure to drill squarely through door.

C. Attach Door to Hinge

- Fasten door to door leaf with the barrel nuts and 1/4-20 shoulder screws.

NOTE: Always install shoulder screws on the secured side of the door (Fig. 3).

- Mark (or centerpunch) remaining frame leaf hole locations. Drill holes in frame through the frame leaf and secure with flathead screws.

- Secure door to door leaf with barrel nuts and 1/4-20 shoulder screws.

NOTE: Always install shoulder screws on the secured side of the door (Fig. 3).

D. Install Leaf Cover

- Align leaf cover with top edge of hinge.
- Starting from the top and working downward, apply pressure to leaf cover to snap it into place (Fig. 3).

NOTE: If you use a hammer to tap cover into place, be sure to protect the surface of the cover from damage.

- Tighten set screws with 5/64" Allen wrench.